

CURRENT OWNER		TOPO	UTILITIES	STRT / ROAD	LOCATION	CURRENT ASSESSMENT				801 FY2024 BARNSTABLE, MA  <b>VISION</b>	
MACCALLUM, JACQUELINE & BLAKE  211 SLADE ST  BELMONT MA 02478		1 Level	2 Public Water	1 Paved		Description	Code	Assessed	Assessed		
			4 Gas			RESIDNTL	1010	550,000	550,000		
			6 Septic			RES LAND	1010	150,600	150,600		
<b>SUPPLEMENTAL DATA</b>						Total				700,600	700,600
Alt Prcl ID Split Zonin BID Parcel ResExpt Q #DL 1 UNNUM #DL 2 GIS ID F_987239_2696680				Plan Ref. 344/70 Land Ct# #SR Life Estate PP STATU Assoc Pid#							

RECORD OF OWNERSHIP		BK-VOL/PAGE	SALE DATE	Q/U	V/I	SALE PRIC	VC	PREVIOUS ASSESSMENTS (HISTORY)					
MACCALLUM, JACQUELINE & BLAKE, VI		28258 0073	07-11-2014	Q	I	320,000	00	Year	Code	Assessed	Year	Code	Assessed
KRISTO, LEA F & STAMOULIS, EVAN LO		13453 0264	12-28-2000	U	I	100	1F	2023	1010	463,400	2022	1010	378,900
STAMOULIS, KATHERINE		8144 0129	08-15-1992	U	I	1	1F		1010	136,900		1010	101,400
STAMOULIS, LOUIS & KATHERINE		5209 0012	07-15-1986	Q	I	118,000	00					1010	4,300
PARRELLA, DAVID A&CYNTHIA H		3879 0268	09-15-1983	U	I	31,000	D	Total		600,300	Total		480,300
								Total		411,400	Total		411,400

EXEMPTIONS			OTHER ASSESSMENTS				This signature acknowledges a visit by a Data Collector or Assessor								
Year	Code	Description	Amount	Code	Description	Number	Amount	Comm Int							
Total			0.00												

ASSESSING NEIGHBORHOOD				APPRAISED VALUE SUMMARY			
Nbhd	Nbhd Name	B	Tracing	Batch			
0105				HYAN			
<b>NOTES</b>				Appraised Bldg. Value (Card) 535,000			
				Appraised Xf (B) Value (Bldg) 10,700			
				Appraised Ob (B) Value (Bldg) 4,300			
				Appraised Land Value (Bldg) 150,600			
				Special Land Value 0			
				Total Appraised Parcel Value 700,600			
				Valuation Method C			
				Total Appraised Parcel Value 700,600			

BUILDING PERMIT RECORD									VISIT / CHANGE HISTORY					
Permit Id	Issue Date	Type	Description	Amount	Insp Date	% Comp	Date Comp	Comments	Date	Id	Type	Is	Cd	Purpost/Result
201400466	01-29-2014	RW	Repair Work	684	09-04-2014	100	06-30-2015	RW WTR DAMG	05-08-2020	WD			FR	Field Review
B30370	01-01-1987	AD	Addition	35,000	01-15-1988	100	06-30-1988	AD HYANNIS	12-05-2014	MW	01		02	Bldg Permit Completed
									08-30-2014	SR	02		03	Cycl Insp Comp
									08-29-2014	MW	02		13	CALL BACK
									03-15-2002	PT	01		00	Meas/Listed-Interior Acces
									04-15-1988	ME	02		01	Meas/Est

LAND LINE VALUATION SECTION																
B	Use Code	Description	Zone	LA	Land Units	Unit Price	Size Adj	AC Disc	Site Index	Cond.	Nbhd.	Nbhd. Adj	Notes	Location Adjustmen	Adj Unit P	Land Value
1	1010	Single Fam M-0	RB	4	0.300 AC	176,344.00	2.84692	1.0000	5	1.00	0105	1.000		1.0000	502,033.7	150,600
Total Card Land Units					0.30	AC	Parcel Total Land Area					0.30	Total Land Value			150,600

CONSTRUCTION DETAIL			CONSTRUCTION DETAIL (CONTINUED)		
Element	Cd	Description	Element	Cd	Description
Style	06	Conventional			
Model	01	Residential			
Grade:	B	Custom			
Stories	1.66				
Exterior Wall 1	14	Wood Shingle			
Exterior Wall 2	11	Clapboard			
RooF Structure	03	Gable/Hip			
RooF Cover	03	Asph/F Gls/Cmp			
Interior Wall 1	03	Plastered			
Interior Wall 2					
Interior Floor 1	14	Carpet			
Interior Floor 2	23	Laminate			
Heat Fuel	02	Oil			
Heat Type	05	Hot Water			
AC Type	01	None			
Bedrooms	03	3 Bedrooms			
Full Baths	2				
Half Baths	0				
Extra Fixtures					
Total Rooms	7	7 Rooms			
Bath Style					
Kitchen Style					
Occupancy					
Usrflid 105					
Accessory Apt					
Foundation Alt	10	Brick Ftgs			
Rms Prts					
Bath Split	20	2 Full-0 Half			

CONDO DATA			
Parcel Id		C	Owne 0.0
Adjust Type	Code	Description	Factor%
Condo Flr			
Condo Unit			

COST / MARKET VALUATION	
Building Value New	636,871
Year Built	1870
Effective Year Built	1999
Depreciation Code	E
Remodel Rating	
Year Remodeled	
Depreciation %	16
Functional Obsol	0
External Obsol	0
Trend Factor	1
Condition	
Condition %	
Percent Good	84
RCNLD	535,000
Dep % Ovr	
Dep Ovr Comment	
Misc Imp Ovr	
Misc Imp Ovr Comment	
Cost to Cure Ovr	
Cost to Cure Ovr Comment	

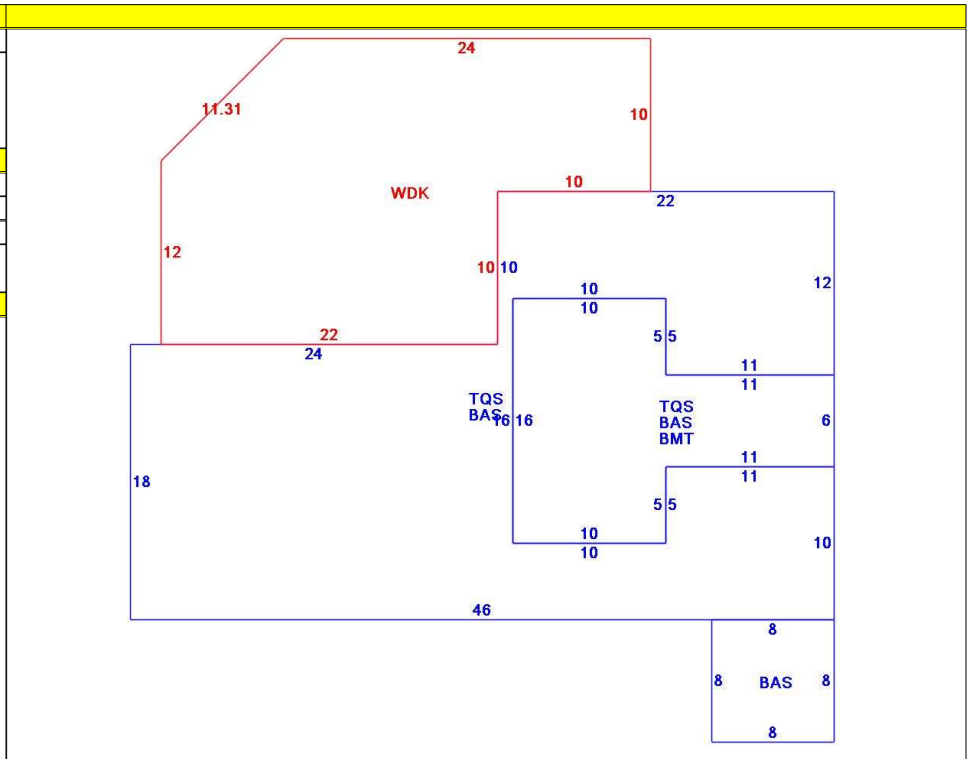

OB - OUTBUILDING & YARD ITEMS(L) / XF - BUILDING EXTRA FEATURES(B)										
Code	Description	L/B	Units	Unit Price	Yr Blt	Cond. Cd	% Gd	Grade	Grade Adj.	Appr. Value
FPLG	Gas Fireplace	B	1	2500.00	1999		84		0.00	2,100
WDC	Wood Deck w/	L	508	18.00	1986		34		0.00	2,900
BMT	Basement-Unfi	B	226	26.01	1999		84		0.00	8,600
SHED	Shed	L	80	18.00	2019		100		0.00	1,400

BUILDING SUB-AREA SUMMARY SECTION						
Code	Description	Living Area	Floor Area	Eff Area	Unit Cost	Undeprec Value
BAS	First Floor	1,112	1,112	1,112	355.20	394,981
BMT	Basement Area	0	226	0	0.00	0
TQS	Three Quarter Story	681	1,048	681	230.81	241,890
WDK	Wood Deck	0	508	0	0.00	0
Ttl Gross Liv / Lease Area		1,793	2,894	1,793		636,871

