

CURRENT OWNER		TOPO	UTILITIES	STRT / ROAD	LOCATION	CURRENT ASSESSMENT						801 FY2024 BARNSTABLE, MA VISION							
ROZUM, KAREN F 15 A JUGGERNAUT ROAD PROSPECT CT 06712						Description	Code	Assessed	Assessed										
						RESIDNTL	1020	128,000	128,000										
SUPPLEMENTAL DATA																			
Alt Prcl ID		Split Zonin		Plan Ref.															
#DL 1		UNIT M1		Land Ct# 36029-C-1 LOT 2															
#DL 2		BLDG 10		#SR															
GIS ID		F_987476_2696069		Life Estate															
				PP STATU															
				Assoc Pid#															
						Total		128,000	128,000										
RECORD OF OWNERSHIP			BK-VOL/PAGE	SALE DATE	Q/U	V/I	SALE PRICE	VC	PREVIOUS ASSESSMENTS (HISTORY)										
ROZUM, KAREN F			C144	0	05-04-2015	U	I	56,555	1S	Year	Code	Assessed	Year	Code	Assessed	Year	Code	Assessed	
US BANK NATIONAL ASSOCIATION			C144	0	09-26-2013	U	I	60,350	1L	2023	1020	140,500	2022	1020	105,400	2021	1020	78,100	
TOSCANO, ELIZABETH M&GULDEN, LINDA			C144	0	04-11-2007	U	I	1	1A								1020	2,100	
TOSCANO, ELIZABETH M ET AL			C144	0	08-31-2005	U	I	1	1A										
GULDEN, LINDA JILL			C144	0	06-25-2004	U	I	1	1A										
						Total		140,500		Total		105,400	Total		80,200				
EXEMPTIONS			OTHER ASSESSMENTS						This signature acknowledges a visit by a Data Collector or Assessor										
Year	Code	Description	Amount	Code	Description	Number	Amount	Comm Int											
Total			0.00																
ASSESSING NEIGHBORHOOD						APPRAISED VALUE SUMMARY													
Nbhd	Nbhd Name	B	Tracing	Batch															
0001				HYAN															
NOTES						VISIT / CHANGE HISTORY													
BUILDING PERMIT RECORD						VISIT / CHANGE HISTORY													
Permit Id	Issue Date	Type	Description	Amount	Insp Date	% Comp	Date Comp	Comments	Date	Id	Type	Is	Cd	Purpost/Result					
EXPR-22-2	02-28-2022	835	Sid/Wind/Roof/	2,470		100		WEATHERIZATION, AIR SEA	05-08-2020	WD			FR	Field Review					
EXPR-22-2	02-23-2022	835	Sid/Wind/Roof/	2,470		100		Air Sealing, Attic Damming, 11	04-10-2019	SR	02		03	Cycl Insp Comp					
B37728	05-01-1995	WD	Wood Deck	2,000	01-15-1996	100		HY DECK	01-18-2017	AL	22		22	Change of Address					
LAND LINE VALUATION SECTION																			
B	Use Code	Description	Zone	Dist	Land Type	Land Units	Unit Price	Size Adj	Site Index	Cond.	Nbhd.	Nbhd. Adj	Notes	Location Adjustmen	Adj Unit P	Land Value			
1	102U	Condominium M	RB	4		0 SF	0.00	1.00000	5	1.00	0001	1.000		0.0000	0	0			
Total Card Land Units						0	SF	Parcel Total Land Area						0.00	Total Land Value			0	

CONSTRUCTION DETAIL			CONSTRUCTION DETAIL (CONTINUED)		
Element	Cd	Description	Element	Cd	Description
Style	55	Condominium			
Model	05	Res Condo			
Bedrm Func	C	Average			
Stories	1	1 Story			
Occupancy	0				
Interior Wall 1	05	Drywall			
Interior Wall 2					
Interior Floor 1	14	Carpet			
Interior Floor 2					
Heat Fuel	03	Gas			
Heat Type	04	Hot Air			
AC Type	01	None			
Bedrooms	01	1 Bedroom			
Full Baths	1	1 Full			
Half Baths	0				
Extra Fixtures					
Total Rooms	2	2 Rooms			
Bath Style					
Kitchen Style					
Master Deed L	253				
Bath Split	10	1 Full-0 Half			
Foundation	03	Conc. Slab			
AC Type Alt					
Sewer Occupan					
CONDO DATA					
Parcel Id	104214	C 0110	Ownr	1.2	
	CAPTAIN GOSNOL	B 1	S 1		
Adjust Type	Code	Description	Factor%		
Condo Flr			100		
Condo Unit	MKT0	MKT0	100		
COST / MARKET VALUATION					
Building Value New		163,471			
Year Built		1951			
Effective Year Built		1989			
Depreciation Code		A			
Remodel Rating					
Year Remodeled					
Depreciation %		23			
Functional Obsol		0			
External Obsol		0			
Trend Factor		1			
Condition					
Condition %					
Percent Good		77			
Cns Sect Rcnd		125,900			
Dep % Ovr					
Dep Ovr Comment					
Misc Imp Ovr					
Misc Imp Ovr Comment					
Cost to Cure Ovr					
Cost to Cure Ovr Comment					

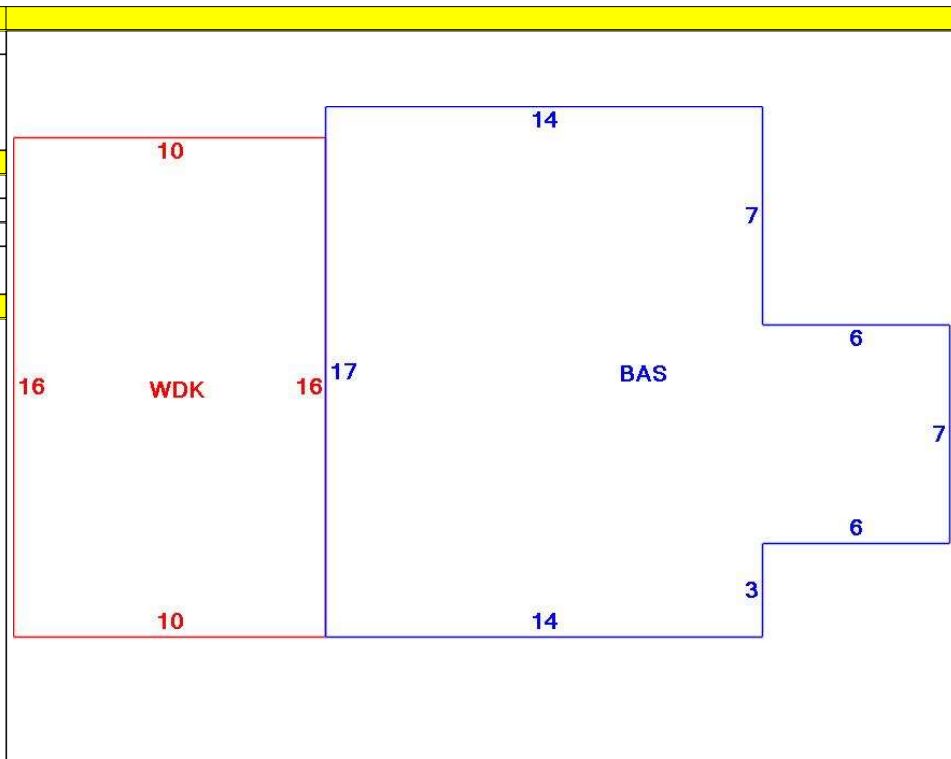

OB - OUTBUILDING & YARD ITEMS(L) / XF - BUILDING EXTRA FEATURES(B)										
Code	Description	L/B	Units	Unit Price	Yr Blt	Cond. Cd	% Gd	Grade	Grade Adj.	Appr. Value
WDC	Wood Decking	L	160	20.00	1994		50		0.00	2,100

BUILDING SUB-AREA SUMMARY SECTION						
Code	Description	Living Area	Floor Area	Eff Area	Unit Cost	Undeprec Value
BAS	First Floor	280	280	280	583.83	163,471
WDC	Wood Deck	0	160	0	0.00	0
Ttl Gross Liv / Lease Area		280	440	280		163,471

