

CURRENT OWNER				TOPO	UTILITIES	STRT / ROAD	LOCATION	CURRENT ASSESSMENT					
MEECE, DANIEL A				1 Level	1 All Public	1 Paved		Description	Code	Assessed	Assessed	801 FY2024 BARNSTABLE, MA	
180 GOSNOLD STREET								RESIDNTL	1010	586,400	586,400		
HYANNIS MA 02601								RES LAND	1010	234,700	234,700		
SUPPLEMENTAL DATA								Total				821,100	821,100
Alt Prcl ID				Plan Ref.								VISION	
Split Zonin				Land Ct#									
BID Parcel				#SR									
ResExpt Q YES:				Life Estate									
#DL 1				PP STATU D:Deleted									
#DL 2				Assoc Pid#									
GIS ID F_987969_2696091													

RECORD OF OWNERSHIP				BK-VOL/PAGE	SALE DATE	Q/U	V/I	SALE PRIC	VC	PREVIOUS ASSESSMENTS (HISTORY)					
MEECE, DANIEL A				25362 0319	04-05-2011	U	I	1	1A	Year	Code	Assessed	Year	Code	Assessed
MEECE, KATHLEEN E				17349 0066	07-28-2003	U	I	1	1A	2023	1010	549,600	2022	1010	518,500
MEECE, KATHLEEN E				17349 0064	07-28-2003	U	I	1	1A		1010	213,400		1010	146,800
IRELAND, JOHN F & EUNICE H				1909 0047	07-31-1973	U		0						1010	326,000
Total										Total	763,000	Total	665,300	Total	630,600

EXEMPTIONS				OTHER ASSESSMENTS				
Year	Code	Description	Amount	Code	Description	Number	Amount	Comm Int
2023	5C	RESIDENTIAL EXEMPTION						
Total			0.00					

ASSESSING NEIGHBORHOOD			
Nbhd	Nbhd Name	B	Tracing
0107			Batch HYAN

NOTES			
This signature acknowledges a visit by a Data Collector or Assessor			
APPRAISED VALUE SUMMARY			
Appraised Bldg. Value (Card)			231,600
Appraised Xf (B) Value (Bldg)			28,800
Appraised Ob (B) Value (Bldg)			326,000
Appraised Land Value (Bldg)			234,700
Special Land Value			0
Total Appraised Parcel Value			821,100
Valuation Method			C
Total Appraised Parcel Value			821,100

BUILDING PERMIT RECORD									VISIT / CHANGE HISTORY					
Permit Id	Issue Date	Type	Description	Amount	Insp Date	% Comp	Date Comp	Comments	Date	Id	Type	Is	Cd	Purpost/Result
17-172	01-23-2017	834	Sheet Metal	14,500	06-30-2017	100	06-30-2017	supply and install 60 k btv furn	01-23-2023	JO	03		16	In Office Review
201400976	02-18-2014	SP	Swimming Pool	70,000	06-18-2015	100	06-30-2015	SWIMMING POOL 30X40 HE	05-08-2020	WD			FR	Field Review
201400378	02-18-2014	AD	Addition	26,732	06-30-2017	100	06-30-2017	ADD POOL HSE TO EXIST G	05-02-2018	SR	01		02	Bldg Permit Completed
201102951	06-06-2011	NR	New Roof	1,100	06-30-2011	100	06-30-2011	REROOF STRIPPING OLD	07-26-2017	SR	02		13	CALL BACK
201101639	03-30-2011	NS	New Siding	6,000	06-30-2011	100	06-30-2011	RESIDE	05-18-2016	SR	02		13	CALL BACK
									06-23-2015	SR	02		13	CALL BACK
									12-11-2014	MW	02		02	Bldg Permit Completed

LAND LINE VALUATION SECTION																
B	Use Code	Description	Zone	LA	Land Units	Unit Price	Size Adj	AC Disc	Site Index	Cond.	Nbhd.	Nbhd. Adj	Notes	Location Adjustmen	Adj Unit P	Land Value
1	1010	Single Fam M-0	RB	4	0.650 AC	176,344.00	1.46256	1.0000	5	1.00	0107	1.400		1.0000	361,081.9	234,700
Total Card Land Units					0.65	AC	Parcel Total Land Area					0.65	Total Land Value			234,700

CONSTRUCTION DETAIL			CONSTRUCTION DETAIL (CONTINUED)		
Element	Cd	Description	Element	Cd	Description
Style	01	Ranch			
Model	01	Residential			
Grade:	C	Average			
Stories	1	1 Story			
Exterior Wall 1	14	Wood Shingle			
Exterior Wall 2					
RooF Structure	03	Gable/Hip			
RooF Cover	03	Asph/F Gls/Cmp			
Interior Wall 1	05	Drywall			
Interior Wall 2					
Interior Floor 1	09	Pine/Soft Wood			
Interior Floor 2					
Heat Fuel	03	Gas			
Heat Type	05	Hot Water			
AC Type	01	None			
Bedrooms	02	2 Bedrooms			
Full Baths	1				
Half Baths	0				
Extra Fixtures					
Total Rooms	7	7 Rooms			
Bath Style					
Kitchen Style					
Occupancy					
UsrflD 105					
Accessory Apt					
Foundation Alt	02	Conc. Block			
Rms Prts					
Bath Split	10	1 Full-0 Half			

CONDO DATA

Parcel Id		C		Ownr	0.0
Adjust Type	Code	Description	Factor%		
Condo Flr					
Condo Unit					

COST / MARKET VALUATION

Building Value New	317,233
Year Built	1930
Effective Year Built	1984
Depreciation Code	G
Remodel Rating	
Year Remodeled	
Depreciation %	27
Functional Obsol	0
External Obsol	0
Trend Factor	1
Condition	
Condition %	
Percent Good	73
RCNLD	231,600
Dep % Ovr	
Dep Ovr Comment	
Misc Imp Ovr	
Misc Imp Ovr Comment	
Cost to Cure Ovr	
Cost to Cure Ovr Comment	

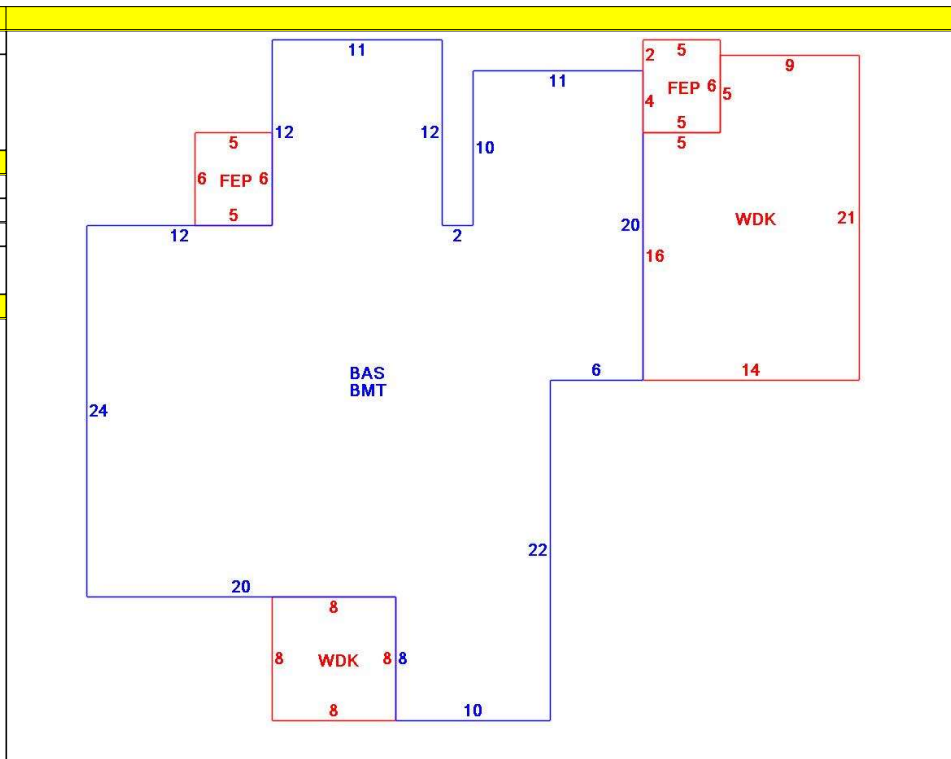

OB - OUTBUILDING & YARD ITEMS(L) / XF - BUILDING EXTRA FEATURES(B)

Code	Description	L/B	Units	Unit Price	Yr Blt	Cond. Cd	% Gd	Grade	Grade Adj.	Appr. Value
FPL1	Fireplace 1 sto	B	1	5000.00	1984		73		0.00	3,700
SHD2	Shed w/Elec	L	320	26.00	1990		42		0.00	3,500
FEP	Enclosed porc	B	60	70.00	1984		73		0.00	4,400
BMT	Basement-Unfi	B	1,102	26.01	1984		73		0.00	20,700
WDC	Wood Decking	L	333	20.00	1987		36		0.00	2,400
SPL2	Pool Vinyl	L	1,200	55.00	2014		90	00	1.00	52,600
PATS	Patio-Concrete	L	4,396	20.00	2014		95		0.00	62,900
JCZ1	Jacuzzi Outsid	L	1	9822.00	2014		90		0.00	8,800
SPH4	Pool Heater 10	L	1	5454.00	2014		90		0.00	4,900
CNPF	Canopy-free st	L	225	11.92	2014		95		0.00	2,500

BUILDING SUB-AREA SUMMARY SECTION

Code	Description	Living Area	Floor Area	Eff Area	Unit Cost	Undeprec Value
BAS	First Floor	1,102	1,102	1,102	287.87	317,233
BMT	Basement Area	0	1,102	0	0.00	0
FEP	Enclosed Porch	0	60	0	0.00	0
WDC	Wood Deck	0	333	0	0.00	0
Ttl Gross Liv / Lease Area		1,102	2,597	1,102		317,233



5.3.2018

CURRENT OWNER			TOPO	UTILITIES	STRT / ROAD	LOCATION	CURRENT ASSESSMENT				
MEECE, DANIEL A			1 Level	1 All Public	1 Paved		Description	Code	Assessed	Assessed	801 FY2024 BARNSTABLE, MA
180 GOSNOLD STREET							RESIDNTL	1010	586,400	586,400	
HYANNIS MA 02601							RES LAND	1010	234,700	234,700	
SUPPLEMENTAL DATA											
Alt Prcl ID Split Zonin BID Parcel ResExpt Q YES: #DL 1 #DL 2 GIS ID F_987969_2696091					Plan Ref. Land Ct# #SR Life Estate PP STATU D:Deleted Assoc Pid#		Total		821,100	821,100	VISION

RECORD OF OWNERSHIP			BK-VOL/PAGE	SALE DATE	Q/U	V/I	SALE PRIC	VC	PREVIOUS ASSESSMENTS (HISTORY)					
									Year	Code	Assessed	Year	Code	Assessed
									2023	1010	549,600	2022	1010	518,500
										1010	213,400		1010	146,800
									Total		763,000	Total		665,300
									Total			Total		630,600

EXEMPTIONS			OTHER ASSESSMENTS					APPRAISED VALUE SUMMARY						
Year	Code	Description	Amount	Code	Description	Number	Amount	Comm Int	This signature acknowledges a visit by a Data Collector or Assessor					
									Appraised Bldg. Value (Card) 231,600					
Total									Appraised Xf (B) Value (Bldg) 28,800					
ASSESSING NEIGHBORHOOD								Appraised Ob (B) Value (Bldg) 326,000						
Nbhd	Nbhd Name		B	Tracing		Batch		Appraised Land Value (Bldg) 234,700						
0107						HYAN		Special Land Value 0						
NOTES												Total Appraised Parcel Value 821,100		
												Valuation Method C		
												Total Appraised Parcel Value 821,100		

BUILDING PERMIT RECORD										VISIT / CHANGE HISTORY						
Permit Id	Issue Date	Type	Description	Amount	Insp Date	% Comp	Date Comp	Comments			Date	Id	Type	Is	Cd	Purpost/Result

LAND LINE VALUATION SECTION																
B	Use Code	Description	Zone	LA	Land Units	Unit Price	Size Adj	AC Disc	Site Index	Cond.	Nbhd.	Nbhd. Adj	Notes	Location Adjustmen	Adj Unit P	Land Value
Total Card Land Units					Parcel Total Land Area					Total Land Value						

CONSTRUCTION DETAIL						CONSTRUCTION DETAIL (CONTINUED)					
Element	Cd	Description				Element	Cd	Description			
Style	01	Ranch									
Model	01	Residential									
Grade:	C	Average									
Stories	1	1 Story									
Exterior Wall 1	14	Wood Shingle				CONDO DATA					
Exterior Wall 2						Parcel Id		C		Owne	0.0
Roof Structure	03	Gable/Hip						B		S	
Roof Cover	03	Asph/F Gls/Cmp				Adjust Type	Code	Description		Factor%	
Interior Wall 1	05	Drywall				Condo Flr					
Interior Wall 2						Condo Unit					
Interior Floor 1	09	Pine/Soft Wood				COST / MARKET VALUATION					
Interior Floor 2						Building Value New					
Heat Fuel	03	Gas				Year Built					
Heat Type	05	Hot Water				Effective Year Built					
AC Type	01	None				Depreciation Code					
Bedrooms	02	2 Bedrooms				Remodel Rating					
Full Baths	1					Year Remodeled					
Half Baths	0					Depreciation %					
Extra Fixtures						Functional Obsol					
Total Rooms	7	7 Rooms				External Obsol					
Bath Style						Trend Factor					
Kitchen Style						Condition					
Occupancy						Condition %					
Usrflid 105						Percent Good					
Accessory Apt						RCNLD					
Foundation Alt	02	Conc. Block				Dep % Ovr					
Rms Prts						Dep Ovr Comment					
Bath Split	10	1 Full-0 Half				Misc Imp Ovr					
						Misc Imp Ovr Comment					
						Cost to Cure Ovr					
						Cost to Cure Ovr Comment					
OB - OUTBUILDING & YARD ITEMS(L) / XF - BUILDING EXTRA FEATURES(B)											
Code	Description	L/B	Units	Unit Price	Yr Blt	Cond. Cd	% Gd	Grade	Grade Adj.	Appr. Value	
CNPF	Canopy-free st	L	100	11.92	2014		95		0.00	1,100	
PHS3	Pool Hs/Good,	L	900	180.00	2014		95	B-	1.21	186,200	
FOPD	FOP-CONCR	L	25	31.41	2014		95	C	1.00	1,100	
BUILDING SUB-AREA SUMMARY SECTION											
Code	Description	Living Area	Floor Area	Eff Area	Unit Cost	Undeprec Value					
Ttl Gross Liv / Lease Area											