

CONSTRUCTION DETAIL			CONSTRUCTION DETAIL (CONTINUED)		
Element	Cd	Description	Element	Cd	Description
Style	04	Cape Cod			
Model	01	Residential			
Grade:	C	Average			
Stories	1.75	1 3/4 Stories			
Exterior Wall 1	14	Wood Shingle			
Exterior Wall 2					
RooF Structure	03	Gable/Hip			
RooF Cover	03	Asph/F Gls/Cmp			
Interior Wall 1	05	Drywall			
Interior Wall 2					
Interior Floor 1	12	Hardwood			
Interior Floor 2	23	Laminate			
Heat Fuel	02	Oil			
Heat Type	05	Hot Water			
AC Type	01	None			
Bedrooms	03	3 Bedrooms			
Full Baths	2				
Half Baths	0				
Extra Fixtures					
Total Rooms	7	7 Rooms			
Bath Style					
Kitchen Style					
Occupancy					
UsrflD 105					
Accessory Apt					
Foundation Alt	09	Blk/Pour Ftgs			
Rms Prts					
Bath Split	20	2 Full-0 Half			

CONDO DATA			
Parcel Id		C	Owne 0.0
Adjust Type	Code	Description	Factor%
Condo Flr			
Condo Unit			

COST / MARKET VALUATION	
Building Value New	427,446
Year Built	1930
Effective Year Built	1989
Depreciation Code	VG
Remodel Rating	
Year Remodeled	
Depreciation %	23
Functional Obsol	0
External Obsol	0
Trend Factor	1
Condition	
Condition %	
Percent Good	77
RCNLD	329,100
Dep % Ovr	
Dep Ovr Comment	
Misc Imp Ovr	
Misc Imp Ovr Comment	
Cost to Cure Ovr	
Cost to Cure Ovr Comment	

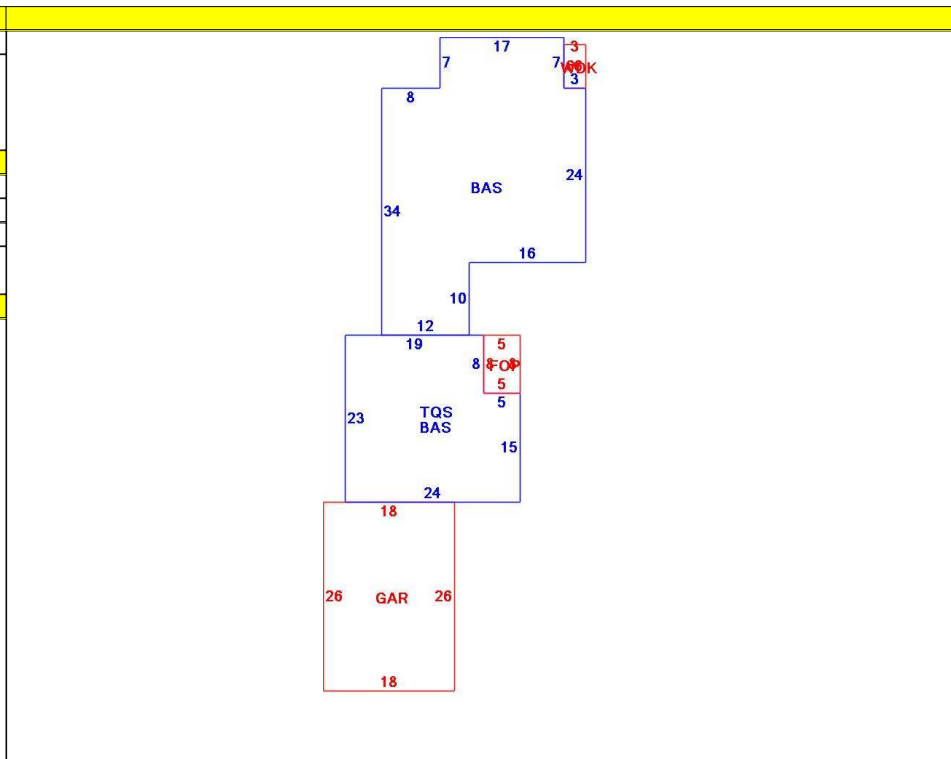

OB - OUTBUILDING & YARD ITEMS(L) / XF - BUILDING EXTRA FEATURES(B)										
Code	Description	L/B	Units	Unit Price	Yr Blt	Cond. Cd	% Gd	Grade	Grade Adj.	Appr. Value
FGR2	Garage- Avg-	L	504	50.00	1950		31	00	1.00	7,800
FOP	Open Porch-ro	B	40	55.00	1989		77		0.00	2,300
GAR	Attached Gara	B	468	40.00	1989		77		0.00	13,700
GEN	Emergency Ge	L	1	5550.00	2005		72		0.00	4,000
WDC	Wood Deck w/	L	18	18.00	1992		46		0.00	600
FPLG	Gas Fireplace-	B	1	2500.00	1989		77		0.00	1,900

BUILDING SUB-AREA SUMMARY SECTION						
Code	Description	Living Area	Floor Area	Eff Area	Unit Cost	Undeprec Value
BAS	First Floor	1,423	1,423	1,423	243.42	346,387
FOP	Open Porch	0	40	0	0.00	0
GAR	Attached Garage	0	468	0	0.00	0
TQS	Three Quarter Story	333	512	333	158.32	81,059
WDK	Wood Deck	0	18	0	0.00	0
Ttl Gross Liv / Lease Area		1,756	2,461	1,756		427,446

