

| CURRENT OWNER | | TOPO | | UTILITIES | | STRT / ROAD | | LOCATION | | CURRENT ASSESSMENT | | | |
|--|--|------|--------|-----------|--------------|---|-------|----------|------------|--------------------------------------|----------------------|----------------------------------|----------------------------------|
| WYLIE, PAUL S & KATHERINE M 10 DESIREE LANE LAKE PLACID NY 12946 | | 1 | Level | 2 | Public Water | 1 | Paved | 1 | Excel View | Description RESIDENTL RES LAND | Code 1010 1010 | Assessed 815,100 1,803,400 | Assessed 815,100 1,803,400 |
| | | 4 | Gas | | | | | | | | | | |
| | | 6 | Septic | | | | | | | | | | |
| SUPPLEMENTAL DATA | | | | | | | | | | | | | |
| Alt Prcl ID Split Zonin BID Parcel ResExpt Q #DL 1 LOTS 55,56 & 57 #DL 2 GIS ID F_988061_2694649 | | | | | | Plan Ref. 9/103 Land Ct# #SR Life Estate PP STATU Assoc Pid# | | | | Total 2,618,500 2,618,500 | | | |

801
 FY2024
 BARNSTABLE, MA
VISION

| RECORD OF OWNERSHIP | | BK-VOL/PAGE | | SALE DATE | | Q/U | | V/I | | SALE PRIC | | VC | | PREVIOUS ASSESSMENTS (HISTORY) | | | | | | |
|-----------------------------|--|-------------|------|------------|--|-----|---|-----|--|-----------|----|-------|------|--------------------------------|-------|------|-----------|-------|------|-----------|
| WYLIE, PAUL S & KATHERINE M | | 15305 | 0186 | 06-27-2002 | | U | I | | | 1 | 1A | Year | Code | Assessed | Year | Code | Assessed | Year | Code | Assessed |
| WYLIE, PAUL STANTON | | 10456 | 0077 | 10-28-1996 | | Q | I | | | 600,000 | 00 | 2023 | 1010 | 690,700 | 2022 | 1010 | 569,100 | 2021 | 1010 | 445,300 |
| BARACH, MICHAEL & HOLLY | | 8986 | 0192 | 01-15-1994 | | U | I | | | 555,000 | 1L | | 1010 | 2,322,600 | | 1010 | 1,189,100 | | 1010 | 1,189,100 |
| NOWAK, STANLEY P TR | | 8986 | 0189 | 01-15-1994 | | U | I | | | 100 | 1 | | | | | | | | 1010 | 24,800 |
| BORNSTEIN, STUART TR | | 8267 | 0158 | 10-15-1992 | | U | I | | | 235,000 | 1L | Total | | 3,013,300 | Total | | 1,758,200 | Total | | 1,659,200 |

| EXEMPTIONS | | | OTHER ASSESSMENTS | | | | | |
|------------|------|-------------|-------------------|------|-------------|--------|--------|----------|
| Year | Code | Description | Amount | Code | Description | Number | Amount | Comm Int |
| Total | | | 0.00 | | | | | |

This signature acknowledges a visit by a Data Collector or Assessor

| ASSESSING NEIGHBORHOOD | | | | |
|------------------------|-----------|---|---------|-------|
| Nbhd | Nbhd Name | B | Tracing | Batch |
| 0119 | | | | HYAN |

| APPRAISED VALUE SUMMARY | |
|-------------------------------|-----------|
| Appraised Bldg. Value (Card) | 769,200 |
| Appraised Xf (B) Value (Bldg) | 21,100 |
| Appraised Ob (B) Value (Bldg) | 24,800 |
| Appraised Land Value (Bldg) | 1,803,400 |
| Special Land Value | 0 |
| Total Appraised Parcel Value | 2,618,500 |
| Valuation Method | C |
| Total Appraised Parcel Value | 2,618,500 |

| NOTES | | | | | | | |
|-------|--|--|--|--|--|--|--|
| | | | | | | | |

| BUILDING PERMIT RECORD | | | | | | | | | VISIT / CHANGE HISTORY | | | | | |
|------------------------|------------|------|-------------|---------|------------|--------|------------|-------------------------|------------------------|----|------|----|----|---------------------|
| Permit Id | Issue Date | Type | Description | Amount | Insp Date | % Comp | Date Comp | Comments | Date | Id | Type | Is | Cd | Purpost/Result |
| 201204423 | 07-24-2012 | RW | Repair Work | 195,000 | 05-07-2013 | 100 | 06-30-2013 | FIRE REPAIR-FRAMING,SHT | 11-03-2020 | CK | 22 | | 22 | Change of Address |
| 201200473 | 01-26-2012 | RW | Repair Work | 10,000 | 05-07-2013 | 100 | 06-30-2013 | REMOV DAM SHTRCK & INS | 05-11-2020 | WD | | | FR | Field Review |
| 164 | 03-14-1995 | AD | Addition | 20,000 | 06-30-1995 | 100 | 06-30-1995 | ADD DORM TO SUNRM | 10-15-2019 | CK | 22 | | 22 | Change of Address |
| B37495 | 03-01-1995 | AD | Addition | 20,000 | 01-15-1996 | 100 | 06-30-1996 | HY SUNROO | 04-19-2017 | SR | 02 | | 14 | Cyclical Inspection |
| B29636 | 07-01-1986 | AD | Addition | 85,000 | 01-15-1988 | 100 | 06-30-1986 | HY REMOD' | 11-19-2013 | RB | 03 | | 16 | In Office Review |
| | | | | | | | | | 10-09-2013 | NF | 02 | | 52 | New Construction |
| | | | | | | | | | 05-07-2013 | MW | 02 | | 52 | New Construction |

| LAND LINE VALUATION SECTION | | | | | | | | | | | | | | | | | |
|-----------------------------|----------|----------------|------|----|------------|------------|------------------------|---------|------------|-------|-------|-----------|------------------|--------------------|------------|------------|-----------|
| B | Use Code | Description | Zone | LA | Land Units | Unit Price | Size Adj | AC Disc | Site Index | Cond. | Nbhd. | Nbhd. Adj | Notes | Location Adjustmen | Adj Unit P | Land Value | |
| 1 | 1010 | Single Fam M-0 | RB | 4 | 0.290 | AC | 176,344.00 | 2.93869 | 1.0000 | 5 | 1.00 | 0119 | 12.000 | | 1.0000 | 6,218,665 | 1,803,400 |
| Total Card Land Units | | | | | 0.29 | AC | Parcel Total Land Area | | | | | 0.29 | Total Land Value | | | | 1,803,400 |

| CONSTRUCTION DETAIL | | | CONSTRUCTION DETAIL (CONTINUED) | | |
|---------------------|------|----------------|--------------------------------------|----|-------------|
| Element | Cd | Description | Element | Cd | Description |
| Style | 06 | Conventional | | | |
| Model | 01 | Residential | | | |
| Grade: | C+ | Average Plus | | | |
| Stories | 1.75 | 1 3/4 Stories | | | |
| Exterior Wall 1 | 14 | Wood Shingle | | | |
| Exterior Wall 2 | | | | | |
| RooF Structure | 03 | Gable/Hip | | | |
| RooF Cover | 03 | Asph/F Gls/Cmp | | | |
| Interior Wall 1 | 03 | Plastered | | | |
| Interior Wall 2 | | | | | |
| Interior Floor 1 | 14 | Carpet | | | |
| Interior Floor 2 | 12 | Hardwood | | | |
| Heat Fuel | 03 | Gas | | | |
| Heat Type | 04 | Hot Air | | | |
| AC Type | 03 | Central | | | |
| Bedrooms | 04 | 4 Bedrooms | | | |
| Full Baths | 3 | | | | |
| Half Baths | 0 | | | | |
| Extra Fixtures | | | | | |
| Total Rooms | 9 | 9 Rooms | | | |
| Bath Style | | | | | |
| Kitchen Style | | | | | |
| Occupancy | | | | | |
| Usrflid 105 | | | | | |
| Accessory Apt | | | | | |
| Foundation Alt | 02 | Conc. Block | | | |
| Rms Prts | | | | | |
| Bath Split | 30 | 3 Full-0 Half | | | |
| | | | CONDO DATA | | |
| | | | Parcel Id | C | Owne 0.0 |
| | | | Adjust Type Code Description Factor% | | |
| | | | Condo Flr | | |
| | | | Condo Unit | | |
| | | | COST / MARKET VALUATION | | |
| | | | Building Value New | | 915,691 |
| | | | Year Built | | 1920 |
| | | | Effective Year Built | | 1999 |
| | | | Depreciation Code | | E |
| | | | Remodel Rating | | |
| | | | Year Remodeled | | |
| | | | Depreciation % | | 16 |
| | | | Functional Obsol | | 0 |
| | | | External Obsol | | 0 |
| | | | Trend Factor | | 1 |
| | | | Condition | | |
| | | | Condition % | | |
| | | | Percent Good | | 84 |
| | | | RCNLD | | 769,200 |
| | | | Dep % Ovr | | |
| | | | Dep Ovr Comment | | |
| | | | Misc Imp Ovr | | |
| | | | Misc Imp Ovr Comment | | |
| | | | Cost to Cure Ovr | | |
| | | | Cost to Cure Ovr Comment | | |

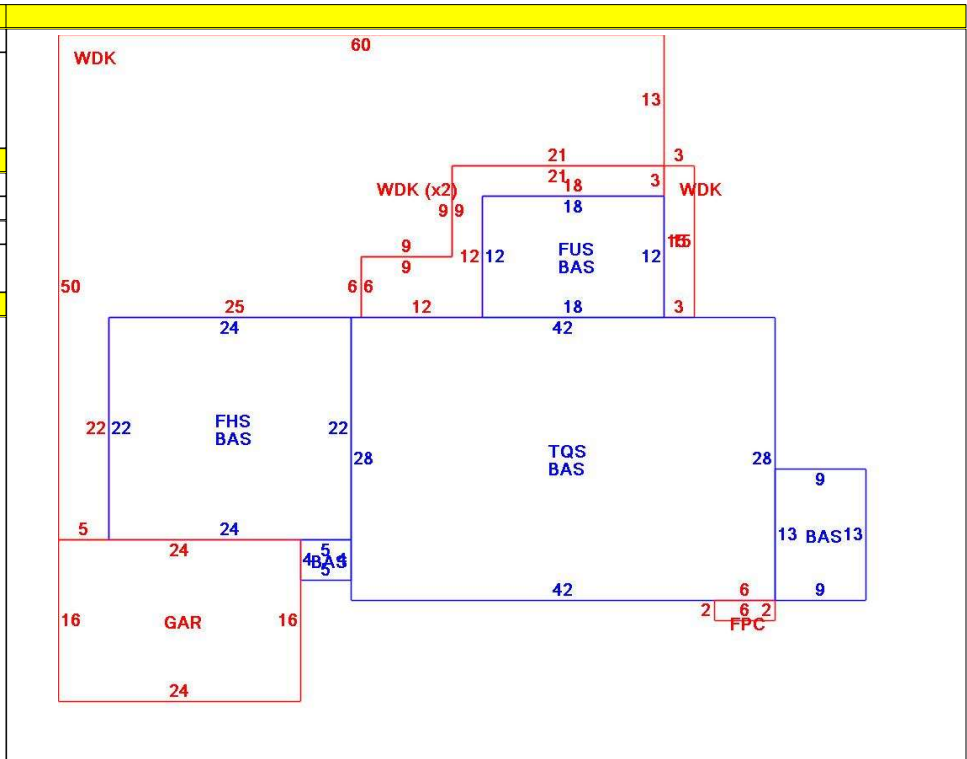

| OB - OUTBUILDING & YARD ITEMS(L) / XF - BUILDING EXTRA FEATURES(B) | | | | | | | | | | |
|--|-----------------|-----|-------|------------|--------|----------|------|-------|------------|-------------|
| Code | Description | L/B | Units | Unit Price | Yr Blt | Cond. Cd | % Gd | Grade | Grade Adj. | Appr. Value |
| FPL2 | Fireplace 1.5 s | B | 1 | 6000.00 | 1999 | | 84 | | 0.00 | 5,000 |
| WDC | Wood Deck w/ | L | 1,574 | 18.00 | 2001 | | 64 | | 0.00 | 15,900 |
| GAR | Attached Gara | B | 384 | 40.00 | 1999 | | 84 | | 0.00 | 13,100 |
| STRS | Stairs to Water | L | 6 | 122.52 | 2002 | | 66 | C | 1.00 | 500 |
| GEN | Emergency Ge | L | 1 | 5550.00 | 2012 | | 86 | | 0.00 | 4,800 |
| WDC | Wood Decking | L | 198 | 20.00 | 2007 | | 76 | | 0.00 | 3,600 |
| FOPC | Open Prch-roo | B | 12 | 55.00 | 1999 | | 84 | | 0.00 | 900 |
| FPLG | Gas Fireplace- | B | 1 | 2500.00 | 1999 | | 84 | | 0.00 | 2,100 |

| BUILDING SUB-AREA SUMMARY SECTION | | | | | | |
|-----------------------------------|------------------------|-------------|------------|----------|-----------|----------------|
| Code | Description | Living Area | Floor Area | Eff Area | Unit Cost | Undeprec Value |
| BAS | First Floor | 2,057 | 2,057 | 2,057 | 277.40 | 570,608 |
| FHS | Half Story | 264 | 528 | 264 | 138.70 | 73,233 |
| FPC | Open Porch Conc. Floor | 0 | 12 | 0 | 0.00 | 0 |
| FUS | Upper Story | 216 | 216 | 216 | 277.40 | 59,918 |
| GAR | Attached Garage | 0 | 384 | 0 | 0.00 | 0 |
| TQS | Three Quarter Story | 764 | 1,176 | 764 | 180.21 | 211,932 |
| WDK | Wood Deck | 0 | 1,772 | 0 | 0.00 | 0 |
| Ttl Gross Liv / Lease Area | | 3,301 | 6,145 | 3,301 | | 915,691 |

