

CURRENT OWNER		TOPO	UTILITIES	STRT / ROAD	LOCATION	CURRENT ASSESSMENT				801 FY2024 BARNSTABLE, MA VISION	
WILLIAMS, RICHARD W & MARGARE 119 MILFORD ST MEDWAY MA 02053	1 Level	2 Public Water	1 Paved			Description	Code	Assessed	Assessed		
		4 Gas				RESIDNTL	1010	330,000	330,000		
		6 Septic				RES LAND	1010	180,100	180,100		
SUPPLEMENTAL DATA						Total				510,100	510,100
Alt Prcl ID Split Zonin BID Parcel ResExpt Q #DL 1 LOT 1 #DL 2 GIS ID F_988186_2698037				Plan Ref. 247/146 Land Ct# #SR Life Estate PP STATU Assoc Pid#							

RECORD OF OWNERSHIP		BK-VOL/PAGE	SALE DATE	Q/U	V/I	SALE PRIC	VC	PREVIOUS ASSESSMENTS (HISTORY)							
WILLIAMS, RICHARD W & MARGARET	10441	0324	10-18-1996	U	I	93,000	1L	Year	Code	Assessed	Year	Code	Assessed		
FEDERAL NATIONAL MORTGAGE ASSO	10211	0076	05-15-1996	U	I	105,000	L	2023	1010	291,500	2022	1010	246,500		
DELANEY, JOSEPH R & KATHLEEN	6444	0235	09-15-1988	Q	I	165,000	U		1010	177,900		1010	126,600		
CROSS, LILLIAN A	6444	0233	09-15-1988	U	I	1	A					1010	1,700		
CROSS, GEORGE L & LILLIAN A	0773	0553	01-08-1951	U		0		Total		469,400	Total		373,100	Total	338,200

EXEMPTIONS			OTHER ASSESSMENTS				This signature acknowledges a visit by a Data Collector or Assessor						
Year	Code	Description	Amount	Code	Description	Number	Amount	Comm	Int				
Total			0.00										

ASSESSING NEIGHBORHOOD				APPRAISED VALUE SUMMARY			
Nbhd	Nbhd Name	B	Tracing	Batch			
0106				HYAN	Appraised Bldg. Value (Card)	304,300	
					Appraised Xf (B) Value (Bldg)	24,000	
					Appraised Ob (B) Value (Bldg)	1,700	
					Appraised Land Value (Bldg)	180,100	
					Special Land Value	0	
					Total Appraised Parcel Value	510,100	
					Valuation Method	C	
					Total Appraised Parcel Value	510,100	

NOTES										VISIT / CHANGE HISTORY					
										Date	Id	Type	Is	Cd	Purpost/Result
										05-08-2020	WD			FR	Field Review
										08-28-2017	SR	01		03	Cycl Insp Comp
										12-22-2014	AL	03		16	In Office Review
										07-22-2014	JR	03		16	In Office Review
										03-18-2002	PT	01		00	Meas/Listed-Interior Acces
										06-15-1988	ML	01		00	Meas/Listed-Interior Acces

BUILDING PERMIT RECORD										LAND LINE VALUATION SECTION					
Permit Id	Issue Date	Type	Description	Amount	Insp Date	% Comp	Date Comp	Comments		Date	Id	Type	Is	Cd	Purpost/Result

B	Use Code	Description	Zone	LA	Land Units	Unit Price	Size Adj	AC Disc	Site Index	Cond.	Nbhd.	Nbhd. Adj	Notes	Location Adjustmen	Adj Unit P	Land Value
1	1010	Single Fam M-0	RB	4	0.480	AC 176,344.00	1.84893	1.0000	5	1.00	0106	1.150		1.0000	374,960.2	180,000
1	1010	Single Fam M-0	RB	4	0.050	AC 2,375.00	1.00000	1.0000	0	1.00	WTLD	1.000	WETLAND	1.0000	2,375	100
Total Card Land Units					0.53	AC	Parcel Total Land Area					0.53	Total Land Value			180,100

CONSTRUCTION DETAIL			CONSTRUCTION DETAIL (CONTINUED)		
Element	Cd	Description	Element	Cd	Description
Style	04	Cape Cod			
Model	01	Residential			
Grade:	C	Average			
Stories	2	2 Stories			
Exterior Wall 1	14	Wood Shingle			
Exterior Wall 2					
RooF Structure	03	Gable/Hip			
RooF Cover	03	Asph/F Gls/Cmp			
Interior Wall 1	05	Drywall			
Interior Wall 2					
Interior Floor 1	14	Carpet			
Interior Floor 2	12	Hardwood			
Heat Fuel	02	Oil			
Heat Type	05	Hot Water			
AC Type	01	None			
Bedrooms	03	3 Bedrooms			
Full Baths	1				
Half Baths	1				
Extra Fixtures					
Total Rooms	7	7 Rooms			
Bath Style					
Kitchen Style					
Occupancy					
Usrflid 105					
Accessory Apt					
Foundation Alt	02	Conc. Block			
Rms Prts					
Bath Split	11	1 Full-1 Half			

CONDO DATA				
Parcel Id		C	Owne	0.0
Adjust Type	Code	Description	Factor%	
Condo Flr				
Condo Unit				

COST / MARKET VALUATION	
Building Value New	434,776
Year Built	1950
Effective Year Built	1981
Depreciation Code	A
Remodel Rating	
Year Remodeled	
Depreciation %	30
Functional Obsol	0
External Obsol	0
Trend Factor	1
Condition	
Condition %	
Percent Good	70
RCNLD	304,300
Dep % Ovr	
Dep Ovr Comment	
Misc Imp Ovr	
Misc Imp Ovr Comment	
Cost to Cure Ovr	
Cost to Cure Ovr Comment	

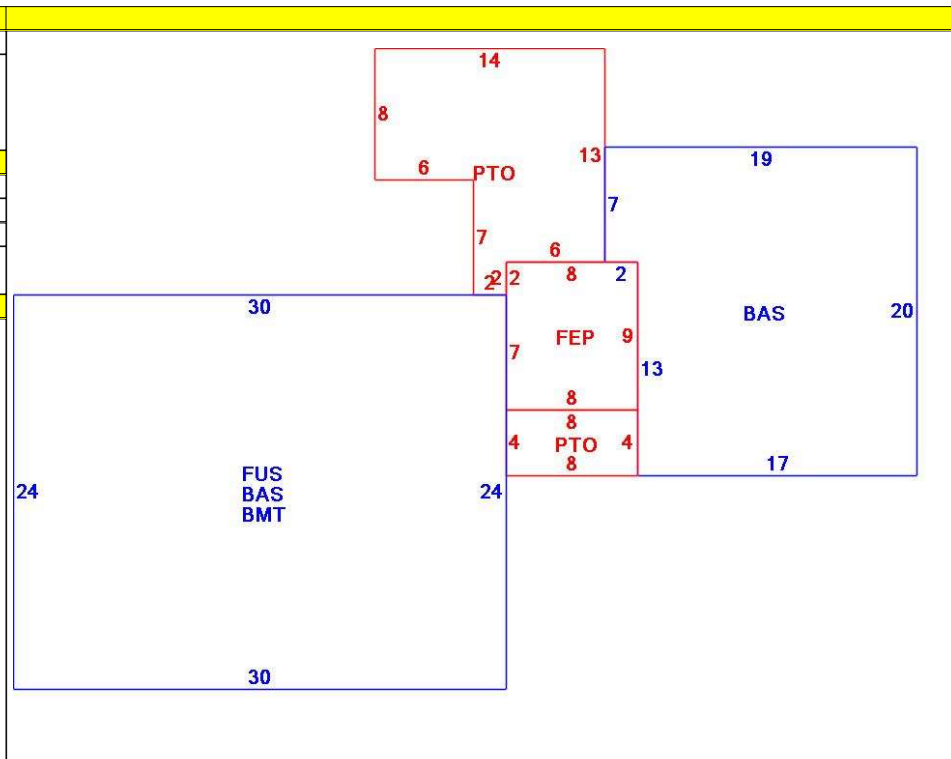

OB - OUTBUILDING & YARD ITEMS(L) / XF - BUILDING EXTRA FEATURES(B)										
Code	Description	L/B	Units	Unit Price	Yr Blt	Cond. Cd	% Gd	Grade	Grade Adj.	Appr. Value
FPL2	Fireplace 1.5 s	B	1	6000.00	1983		70		0.00	4,200
FEP	Enclosed porc	B	72	70.00	1983		70		0.00	4,800
BMT	Basement-Unfi	B	720	26.01	1983		70		0.00	15,000
PAT2	Patio-Good	L	188	9.94	1999		80		0.00	1,700

BUILDING SUB-AREA SUMMARY SECTION						
Code	Description	Living Area	Floor Area	Eff Area	Unit Cost	Undeprec Value
BAS	First Floor	1,074	1,074	1,074	242.35	260,284
BMT	Basement Area	0	720	0	0.00	0
FEP	Enclosed Porch	0	72	0	0.00	0
FUS	Upper Story	720	720	720	242.35	174,492
PTO	Patio	0	188	0	0.00	0
Ttl Gross Liv / Lease Area		1,794	2,774	1,794		434,776

