

CURRENT OWNER		TOPO	UTILITIES	STRT / ROAD	LOCATION	CURRENT ASSESSMENT						801 FY2024 BARNSTABLE, MA  <b>VISION</b>						
BACON TERRACE LLC C/O COMMUNITY SUPPORT ASSOCI P O BOX 1987  HYANNIS MA 02601  Alt Prcl ID Split Zonin BID Parcel ResExpt Q #DL 1 UNITS A, B & C #DL 2 BLDG 1 GIS ID F_986495_2699742						Description	Code	Assessed	Assessed									
						COMMERC.	3430	581,500	581,500									
						SUPPLEMENTAL DATA		Plan Ref. 430/84-85	Land Ct#	#SR	Life Estate			PP STATU				
						Total	581,500	581,500										
RECORD OF OWNERSHIP		BK-VOL/PAGE	SALE DATE	Q/U	V/I	SALE PRICE	VC	PREVIOUS ASSESSMENTS (HISTORY)										
BACON TERRACE LLC		19338 0251	12-13-2004	U	I	1	1A	Year	Code	Assessed	Year	Code	Assessed	Year	Code	Assessed		
BACON TERRACE LLC		18452 0109	04-14-2004	Q	I	408,500	00	2023	3430	581,500	2022	3430	491,900	2021	3430	502,200		
HORAN, MARK & FISH, JOHN TRS		4552 0075	05-15-1985	Q	I	155,000	U									2,200		
						Total	581,500	Total	491,900	Total	504,400							
EXEMPTIONS			OTHER ASSESSMENTS				This signature acknowledges a visit by a Data Collector or Assessor											
Year	Code	Description	Amount	Code	Description	Number	Amount	Comm Int										
									APPRAISED VALUE SUMMARY									
									Appraised Bldg. Value (Card)				537,600					
									Appraised Xf (B) Value (Bldg)				41,700					
									Appraised Ob (B) Value (Bldg)				2,200					
									Appraised Land Value (Bldg)				0					
									Special Land Value				0					
									Total Appraised Parcel Value				581,500					
									Valuation Method				C					
									Total Appraised Parcel Value				581,500					
BUILDING PERMIT RECORD								VISIT / CHANGE HISTORY										
Permit Id	Issue Date	Type	Description	Amount	Insp Date	% Comp	Date Comp	Comments	Date	Id	Type	Is	Cd	Purpost/Result				
16-3443	12-06-2016	835	Sid/Wind/Roof/	16,600	06-30-2017	100	06-30-2017	stripping old asphalt roof and r HY ADD'N	04-30-2020	GM	04		FR	Field Review				
B34908	03-01-1992	AD	Addition	15,000		100			09-10-2019	SR	02			03	Cycl Insp Comp			
									08-01-2013	TP	03			16	In Office Review			
									12-08-2010	TP	03			16	In Office Review			
									09-18-2006	SF	03			16	In Office Review			
									02-15-1993	ML	01			00	Meas/Listed-Interior Acces			
LAND LINE VALUATION SECTION																		
B	Use Code	Description	Zone	Dist	Land Type	Land Units	Unit Price	Size Adj	Site Index	Cond.	Nbhd.	Nbhd. Adj	Notes	Location Adjustmen	Adj Unit P	Land Value		
1	3430	OFF CONDO M-	DMS	4		0 SF	0.00	1.00000	5	1.00	0003	1.000		0.0000	0	0		
Total Card Land Units						0	SF	Parcel Total Land Area						0.00	Total Land Value			0

CONSTRUCTION DETAIL			CONSTRUCTION DETAIL (CONTINUED)		
Element	Cd	Description	Element	Cd	Description
Style	56	Condo Office			
Model	06	Com Condo			
Bedrm Func	C	Average			
Stories	1	1 Story			
Occupancy	0				
Interior Wall 1	05	Drywall			
Interior Wall 2					
Interior Floor 1	14	Carpet			
Interior Floor 2					
Heat Fuel	04	Electric			
Heat Type	07	Elec Baseboard			
AC Type	03	Central			
Bedrooms	00				
Full Baths	2	2 Full			
Half Baths	1				
Extra Fixtures					
Total Rooms	12				
Bath Style					
Kitchen Style					
Master Deed L	4233				
Bath Split	21	2 Full-1 Half			
Foundation	01	Poured Conc.			
AC Type Alt	03				
Sewer Occupan					

CONDO DATA			
Parcel Id	104189	C 0025	Ownr 100
BACON TERRACE		B 1	S 1
Adjust Type	Code	Description	Factor%
Condo Flr			100
Condo Unit	MKT0	MKT0	100

COST / MARKET VALUATION	
Building Value New	689,266
Year Built	1987
Effective Year Built	1991
Depreciation Code	A
Remodel Rating	
Year Remodeled	
Depreciation %	22
Functional Obsol	0
External Obsol	
Trend Factor	1
Condition	
Condition %	
Percent Good	78
Cns Sect Rcnld	537,600
Dep % Ovr	
Dep Ovr Comment	
Misc Imp Ovr	
Misc Imp Ovr Comment	
Cost to Cure Ovr	
Cost to Cure Ovr Comment	

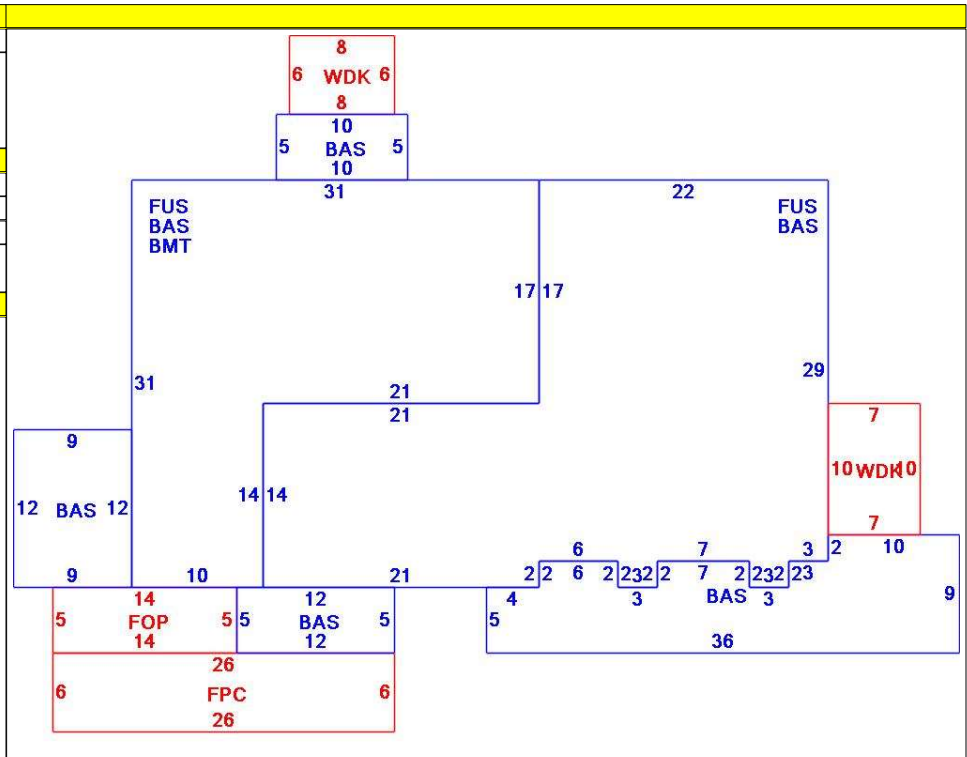

OB - OUTBUILDING & YARD ITEMS(L) / XF - BUILDING EXTRA FEATURES(B)										
Code	Description	L/B	Units	Unit Price	Yr Blt	Cond. Cd	% Gd	Grade	Grade Adj.	Appr. Value
OFLC	Office Finish-L	B	500	44.54	1993		78	C	1.00	17,400
BMT	Basement-Unfi	B	667	26.01	1993		78		0.00	16,000
FOP	Open Porch-ro	B	70	55.00	1993		78		0.00	3,400
FOPC	Open Prch-roo	B	156	55.00	1993		78		0.00	4,900
WDC	Wood Decking	L	118	20.00	1998		58		0.00	2,200

BUILDING SUB-AREA SUMMARY SECTION						
Code	Description	Living Area	Floor Area	Eff Area	Unit Cost	Undeprec Value
BAS	First Floor	2,081	2,081	2,081	182.15	379,060
BMT	Basement Area	0	667	133	36.32	24,226
FOP	Open Porch	0	70	11	28.62	2,004
FPC	Open Porch Conc. Floor	0	156	23	26.86	4,190
FUS	Upper Story	1,611	1,611	1,530	172.99	278,694
WDK	Wood Deck	0	118	6	9.26	1,093
Ttl Gross Liv / Lease Area		3,692	4,703	3,784		689,267

