

CURRENT OWNER			TOPO	UTILITIES	STRT / ROAD	LOCATION	CURRENT ASSESSMENT				801 FY2024 BARNSTABLE, MA  <b>VISION</b>		
BAYRIDGE REALTY LLC							Description	Code	Assessed	Assessed			
76 TUPPER ROAD #10							RESIDENTL	1120	1,029,300	1,029,300			
SANDWICH MA 02563							RES LAND	1120	150,000	150,000			
SUPPLEMENTAL DATA							Total					1,179,300	1,179,300
Alt Prcl ID			Plan Ref. 95/133, 74/133, 1										
Split Zonin			Land Ct#										
BID Parcel			#SR										
ResExpt Q			Life Estate										
#DL 1 LOTS B, A2 & A4			PP STATU										
#DL 2			Assoc Pid#										
GIS ID F_987202_2699728													

RECORD OF OWNERSHIP			BK-VOL/PAGE	SALE DATE	Q/U	V/I	SALE PRIC	VC	PREVIOUS ASSESSMENTS (HISTORY)									
BAYRIDGE REALTY LLC			35037 061	04-08-2022	U	I	1	1F	Year	Code	Assessed	Year	Code	Assessed V	Year	Code	Assessed	
BLACKER, LAWRENCE L TR			33112 0165	07-28-2020	U	I	1,200,000	1L	2023	1120	1,010,500	2022	1120	582,000	2021	1120	582,000	
MOURA PROPERTIES LLC			30801 0078	09-29-2017	U	I	670,000	1V		1120	150,000		1120	150,000		1120	150,000	
HOSTETTER, ADAM J & DANIEL C JR			20286 0157	09-22-2005	U	I	995,000	1V										
CENTERVILLE LLC TR			15489 0306	08-19-2002	U	I	700,000	1										
Total									1,160,500		Total		732,000		Total		732,000	

EXEMPTIONS				OTHER ASSESSMENTS				This signature acknowledges a visit by a Data Collector or Assessor										
Year	Code	Description	Amount	Code	Description	Number	Amount	Comm Int										
Total			0.00															

ASSESSING NEIGHBORHOOD				APPRAISED VALUE SUMMARY										
Nbhd	Nbhd Name	B	Tracing	Batch										
CI11				HYAN										

NOTES										APPRAISED VALUE SUMMARY								
										Appraised Bldg. Value (Card)								1,000,000
										Appraised Xf (B) Value (Bldg)								29,300
										Appraised Ob (B) Value (Bldg)								0
										Appraised Land Value (Bldg)								150,000
										Special Land Value								0
										Total Appraised Parcel Value								1,179,300
										Valuation Method								C
										Total Appraised Parcel Value								1,179,300

BUILDING PERMIT RECORD										VISIT / CHANGE HISTORY							
Permit Id	Issue Date	Type	Description	Amount	Insp Date	% Comp	Date Comp	Comments	Date	Id	Type	Is	Cd	Purpost/Result			
18-733	04-02-2018	835	Sid/Wind/Roof/	0		100		Replace wood Shingles to vinyl	04-06-2020	GM	04		FR	Field Review			
18-732	04-02-2018	835	Sid/Wind/Roof/	4,000		100		Replace Wood shingles to Vin	03-21-2007	TP	03		16	In Office Review			
17-3149	09-25-2017	804	Addn Alt-Res	5,000		100		repair water damage from brok	05-31-2006	JK	22		22	Change of Address			
201303988	06-17-2013	NR	New Roof	5,500	06-30-2013	100	06-30-2013	REROOF STRIPPING OLD	05-15-1988	ML	01		00	Meas/Listed-Interior Acces			
34479	11-02-1998	RW	Repair Work	5,000	01-01-1999	100		REPAIR FIRE DAMAGE									
B32364	10-01-1988	RE	Remodel	25,000		100		HY ALTER.									

LAND LINE VALUATION SECTION																	
B	Use Code	Description	Zone	LA	Land Units	Unit Price	Size Adj	AC Disc	Site Index	Cond.	Nbhd.	Nbhd. Adj	Notes	Location Adjustmen	Adj Unit P	Land Value	
1	1120	APTS 9+/M-07	DMS	4	10	15,000.00	1.00000	1.0000	0	1.00						150,000	
1	1120	APTS 9+/M-07	DMS	4	0.240	0.00	1.00000	1.0000	0	1.00	0105	1.000	10 UNITS ACTUAL LOT SIZE	0.0000	0	0	
Total Card Land Units					0.24	UT	Parcel Total Land Area					0.24	Total Land Value			150,000	

CONSTRUCTION DETAIL			CONSTRUCTION DETAIL (CONTINUED)		
Element	Cd	Description	Element	Cd	Description
Style	14R	Apt House			
Model	07	AptsResModl			
Grade:	C	Average			
Stories	2	2 Stories			
Exterior Wall 1	25	Vinyl Siding			
Exterior Wall 2	20	Brick/Masonry			
Roof Structure	03	Gable/Hip			
Roof Cover	03	Asph/F Gls/Cmp			
Interior Wall 1	03	Plastered			
Interior Wall 2					
Interior Floor 1	14	Carpet			
Interior Floor 2					
Heat Fuel	03	Gas			
Heat Type	05	Hot Water			
AC Type	01	None			
Bedrooms	06	6 Bedrooms			
Full Baths	6				
Half Baths	0				
Extra Fixtures	0				
Total Rooms	12	12 Rooms			
Bath Style					
Kitchen Style					
Occupancy	6				
Usrflid 105	10				
Accessory Apt					
Foundation Alt	02	Conc. Block			
Rms Prts					
Bath Split	60	6 Full-0 Half			
			<b>CONDO DATA</b>		
Parcel Id			C	Owne	0.0
Adjust Type		Code	Description	Factor%	
Condo Flr					
Condo Unit					
			<b>COST / MARKET VALUATION</b>		
Building Value New			1,028,664		
Year Built			1920		
Effective Year Built			1984		
Depreciation Code			G		
Remodel Rating					
Year Remodeled					
Depreciation %			27		
Functional Obsol			5		
External Obsol					
Trend Factor			1		
Condition					
Condition %					
Percent Good			68		
RCNLD			699,500		
Dep % Ovr					
Dep Ovr Comment					
Misc Imp Ovr					
Misc Imp Ovr Comment					
Cost to Cure Ovr					
Cost to Cure Ovr Comment					

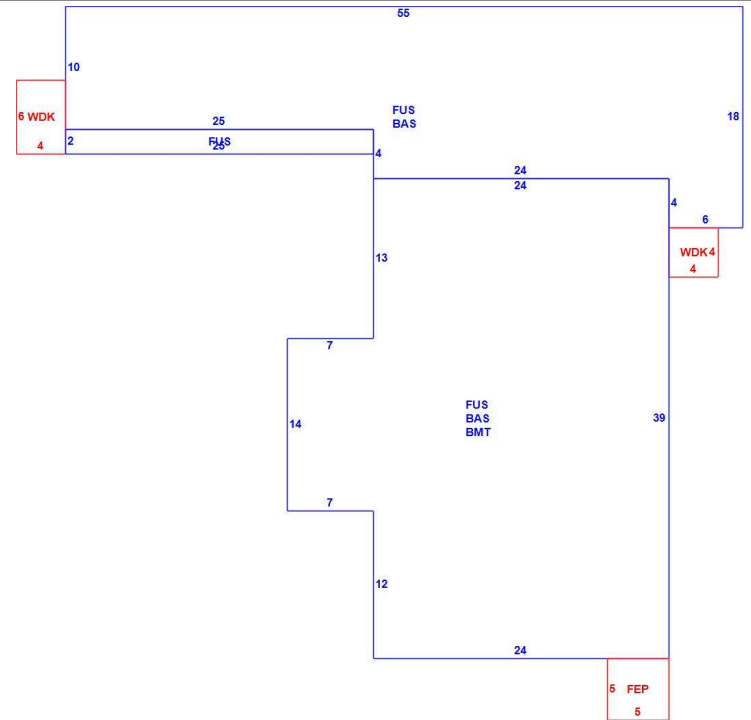

OB - OUTBUILDING & YARD ITEMS(L) / XF - BUILDING EXTRA FEATURES(B)										
Code	Description	L/B	Units	Unit Price	Yr Blt	Cond. Cd	% Gd	Grade	Grade Adj.	Appr. Value
BMT	Basement-Unfi	B	1,034	26.01	1984		68		0.00	18,500

BUILDING SUB-AREA SUMMARY SECTION							
Code	Description	Living Area	Floor Area	Eff Area	Unit Cost	Undeprec Value	
BAS	First Floor	1,728	1,728	1,728	282.99	489,005	
BMT	Basement Area	0	1,034	207	56.65	58,579	
FEP	Enclosed Porch	0	25	9	101.88	2,547	
FUS	Upper Story	1,778	1,778	1,689	268.82	477,968	
WDK	Wood Deck	0	40	2	14.15	566	
Ttl Gross Liv / Lease Area		3,506	4,605	3,635		1,028,665	

CURRENT OWNER			TOPO	UTILITIES	STRT / ROAD	LOCATION	CURRENT ASSESSMENT				
BAYRIDGE REALTY LLC							Description	Code	Assessed	Assessed	801 FY2024 BARNSTABLE, MA
76 TUPPER ROAD #10							RESIDNTL	1120	1,029,300	1,029,300	
SANDWICH MA 02563							RES LAND	1120	150,000	150,000	
SUPPLEMENTAL DATA											
Alt Prcl ID					Plan Ref.		95/133, 74/133, 1				
Split Zonin					Land Ct#						
ResExpt Q					#SR						
#DL 1 LOTS B, A2 & A4					Life Estate						
#DL 2					PP STATU						
GIS ID F_987202_2699728					Assoc Pid#						
								Total	1,179,300	1,179,300	

**VISION**

RECORD OF OWNERSHIP			BK-VOL/PAGE	SALE DATE	Q/U	V/I	SALE PRIC	VC	PREVIOUS ASSESSMENTS (HISTORY)					
BAYRIDGE REALTY LLC	35037	061	04-08-2022	U	I		1	1F	Year	Code	Assessed	Year	Code	Assessed
BLACKER, LAWRENCE L TR	33112	0165	07-28-2020	U	I	1,200,000		1L	2023	1120	1,010,500	2022	1120	582,000
MOURA PROPERTIES LLC	30801	0078	09-29-2017	U	I	670,000		1V		1120	150,000	2021	1120	150,000
HOSTETTER, ADAM J & DANIEL C JR	20286	0157	09-22-2005	U	I	995,000		1V						
CENTERVILLE LLC TR	15489	0306	08-19-2002	U	I	700,000		1						
								Total	1,160,500	Total	732,000	Total	732,000	

EXEMPTIONS			OTHER ASSESSMENTS					
Year	Code	Description	Amount	Code	Description	Number	Amount	Comm Int
Total			0.00					

This signature acknowledges a visit by a Data Collector or Assessor

ASSESSING NEIGHBORHOOD				
Nbhd	Nbhd Name	B	Tracing	Batch
CI11				HYAN

NOTES			

APPRAISED VALUE SUMMARY	
Appraised Bldg. Value (Card)	1,000,000
Appraised Xf (B) Value (Bldg)	29,300
Appraised Ob (B) Value (Bldg)	0
Appraised Land Value (Bldg)	150,000
Special Land Value	0
Total Appraised Parcel Value	1,179,300
Valuation Method	C
Total Appraised Parcel Value	1,179,300

BUILDING PERMIT RECORD							VISIT / CHANGE HISTORY							
Permit Id	Issue Date	Type	Description	Amount	Insp Date	% Comp	Date Comp	Comments	Date	Id	Type	Is	Cd	Purpost/Result

LAND LINE VALUATION SECTION																
B	Use Code	Description	Zone	LA	Land Units	Unit Price	Size Adj	AC Disc	Site Index	Cond.	Nbhd.	Nbhd. Adj	Notes	Location Adjustmen	Adj Unit P	Land Value
2	112R	APT 9+/ResTyp	DMS	4	0 SF	0.00	1.00000	1.0000	0	1.00		1.000		0.0000	0	0
Total Card Land Units					0.00	SF	Parcel Total Land Area					0.24	Total Land Value			0



CURRENT OWNER			TOPO	UTILITIES	STRT / ROAD	LOCATION	CURRENT ASSESSMENT				
BAYRIDGE REALTY LLC							Description	Code	Assessed	Assessed	801 FY2024 BARNSTABLE, MA
76 TUPPER ROAD #10							RESIDNTL	1120	1,029,300	1,029,300	
SANDWICH MA 02563							RES LAND	1120	150,000	150,000	
SUPPLEMENTAL DATA											
Alt Prcl ID					Plan Ref.		95/133, 74/133, 1				
Split Zonin					Land Ct#						
BID Parcel					#SR						
ResExpt Q					Life Estate						
#DL 1 LOTS B, A2 & A4					PP STATU						
#DL 2											
GIS ID F_987202_2699728					Assoc Pid#						
								Total	1,179,300	1,179,300	

**VISION**

RECORD OF OWNERSHIP							BK-VOL/PAGE	SALE DATE	Q/U	V/I	SALE PRIC	VC	PREVIOUS ASSESSMENTS (HISTORY)										
BAYRIDGE REALTY LLC							35037	061	04-08-2022	U	I	1	1F	Year	Code	Assessed	Year	Code	Assessed	Year	Code	Assessed	
BLACKER, LAWRENCE L TR							33112	0165	07-28-2020	U	I	1,200,000	1L	2023	1120	1,010,500	2022	1120	582,000	2021	1120	582,000	
MOURA PROPERTIES LLC							30801	0078	09-29-2017	U	I	670,000	1V		1120	150,000		1120	150,000		1120	150,000	
HOSTETTER, ADAM J & DANIEL C JR							20286	0157	09-22-2005	U	I	995,000	1V										
CENTERVILLE LLC TR							15489	0306	08-19-2002	U	I	700,000	1										
								Total	1,160,500	Total	732,000	Total	732,000										

EXEMPTIONS				OTHER ASSESSMENTS				This signature acknowledges a visit by a Data Collector or Assessor												
Year	Code	Description	Amount	Code	Description	Number	Amount	Comm Int												
			Total	0.00																

ASSESSING NEIGHBORHOOD											
Nbhd	Nbhd Name	B	Tracing	Batch							
CI11				HYAN							

NOTES												APPRAISED VALUE SUMMARY						
R308-106, R308-108												Appraised Bldg. Value (Card)						1,000,000
												Appraised Xf (B) Value (Bldg)						29,300
												Appraised Ob (B) Value (Bldg)						0
												Appraised Land Value (Bldg)						150,000
												Special Land Value						0
												Total Appraised Parcel Value						1,179,300
Valuation Method						C												
Total Appraised Parcel Value						1,179,300												

BUILDING PERMIT RECORD												VISIT / CHANGE HISTORY					
Permit Id	Issue Date	Type	Description	Amount	Insp Date	% Comp	Date Comp	Comments	Date	Id	Type	Is	Cd	Purpost/Result			
									07-03-2021	CK	02		03	Cycl Insp Comp			

LAND LINE VALUATION SECTION																		
B	Use Code	Description	Zone	LA	Land Units	Unit Price	Size Adj	AC Disc	Site Index	Cond.	Nbhd.	Nbhd. Adj	Notes	Location Adjustmen	Adj Unit P	Land Value		
3	112R	APT 9+/ResTyp	DMS	4	0 SF	0.00	1.00000	1.0000	0	1.00		1.000		0.0000	0	0		
Total Card Land Units					0.00	SF	Parcel Total Land Area					0.24	Total Land Value					0

