

CURRENT OWNER		TOPO	UTILITIES	STRT / ROAD	LOCATION	CURRENT ASSESSMENT				801 FY2024 BARNSTABLE, MA VISION
WHITE, ALLEN J TR HOMESTEAD REALTY TR P O BOX 979 HYANNIS MA 02601		1 Level	1 All Public	1 Paved		Description	Code	Assessed	Assessed	
						RESIDNTL	1040	193,500	193,500	
						RES LAND	1040	181,700	181,700	
SUPPLEMENTAL DATA						Total				
Alt Prcl ID Split Zonin BID Parcel ResExpt Q #DL 1 LOT 2 #DL 2 GIS ID F_987490_2699407				Plan Ref. 310/18 Land Ct# #SR Life Estate PP STATU Assoc Pid#						
						Total				375,200

RECORD OF OWNERSHIP		BK-VOL/PAGE	SALE DATE	Q/U	V/I	SALE PRIC	VC	PREVIOUS ASSESSMENTS (HISTORY)					
WHITE, ALLEN J TR GAVIN, KENNETH J & DAVIS GAVIN, JAN		5138 3236	0078 0077	06-15-1986 02-04-1981	Q U	I 0	350,000 0	Year	Code	Assessed	Year	Code	Assessed
								2023	1040 1040	164,400 165,200	2022	1040 1040	136,000 113,600
								Total		329,600	Total		249,600
								Total			Total		228,300

EXEMPTIONS			OTHER ASSESSMENTS				This signature acknowledges a visit by a Data Collector or Assessor								
Year	Code	Description	Amount	Code	Description	Number	Amount	Comm Int							
Total			0.00												

ASSESSING NEIGHBORHOOD				APPRAISED VALUE SUMMARY			
Nbhd	Nbhd Name	B	Tracing	Batch			
0107				HYAN			

NOTES										APPRAISED VALUE SUMMARY			
										Appraised Bldg. Value (Card)	179,800		
										Appraised Xf (B) Value (Bldg)	12,900		
										Appraised Ob (B) Value (Bldg)	800		
										Appraised Land Value (Bldg)	181,700		
										Special Land Value	0		
										Total Appraised Parcel Value	375,200		
										Valuation Method	C		
										Total Appraised Parcel Value	375,200		

BUILDING PERMIT RECORD									VISIT / CHANGE HISTORY					
Permit Id	Issue Date	Type	Description	Amount	Insp Date	% Comp	Date Comp	Comments	Date	Id	Type	Is	Cd	Purpost/Result
17-593	03-09-2017	822	Insulation	1,200	06-30-2017	100	06-30-2017	weatherization	05-07-2020	WD			FR	Field Review
21205	02-19-1997	RE	Remodel	26,000	03-23-1998	100	01-01-1998		09-25-2017	SR	02		03	Cycl Insp Comp
									11-26-2014	JR	03		16	In Office Review
									03-25-2002	PT	01		00	Meas/Listed-Interior Acces
									03-23-1998	LK	02		01	Meas/Est
									05-15-1988	ML	01		00	Meas/Listed-Interior Acces

LAND LINE VALUATION SECTION																
B	Use Code	Description	Zone	LA	Land Units	Unit Price	Size Adj	AC Disc	Site Index	Cond.	Nbhd.	Nbhd. Adj	Notes	Location Adjustmen	Adj Unit P	Land Value
1	1040	Two Family	RB	4	0.100	AC	176,344.00	7.35998	1.0000	5	1.00	0107	1.400		1.0000	1,817,048
Total Card Land Units					0.10	AC	Parcel Total Land Area					0.10	Total Land Value			181,700

CONSTRUCTION DETAIL			CONSTRUCTION DETAIL (CONTINUED)		
Element	Cd	Description	Element	Cd	Description
Style	06	Conventional			
Model	01	Residential			
Grade:	C	Average			
Stories	2	2 Stories			
Exterior Wall 1	14	Wood Shingle			
Exterior Wall 2					
RooF Structure	03	Gable/Hip			
RooF Cover	03	Asph/F Gls/Cmp			
Interior Wall 1	03	Plastered			
Interior Wall 2	04	Plywood Panel			
Interior Floor 1	09	Pine/Soft Wood			
Interior Floor 2					
Heat Fuel	03	Gas			
Heat Type	05	Hot Water			
AC Type	01	None			
Bedrooms	03	3 Bedrooms			
Full Baths	2				
Half Baths	0				
Extra Fixtures					
Total Rooms	5	5 Rooms			
Bath Style					
Kitchen Style					
Occupancy					
Usrflid 105					
Accessory Apt					
Foundation Alt	02	Conc. Block			
Rms Prts					
Bath Split	20	2 Full-0 Half			

CONDO DATA			
Parcel Id		C	Owne 0.0
		B	S
Adjust Type	Code	Description	Factor%
Condo Flr			
Condo Unit			

COST / MARKET VALUATION	
Building Value New	260,621
Year Built	1922
Effective Year Built	1979
Depreciation Code	A
Remodel Rating	
Year Remodeled	
Depreciation %	31
Functional Obsol	0
External Obsol	0
Trend Factor	1
Condition	
Condition %	
Percent Good	69
RCNLD	179,800
Dep % Ovr	
Dep Ovr Comment	
Misc Imp Ovr	
Misc Imp Ovr Comment	
Cost to Cure Ovr	
Cost to Cure Ovr Comment	

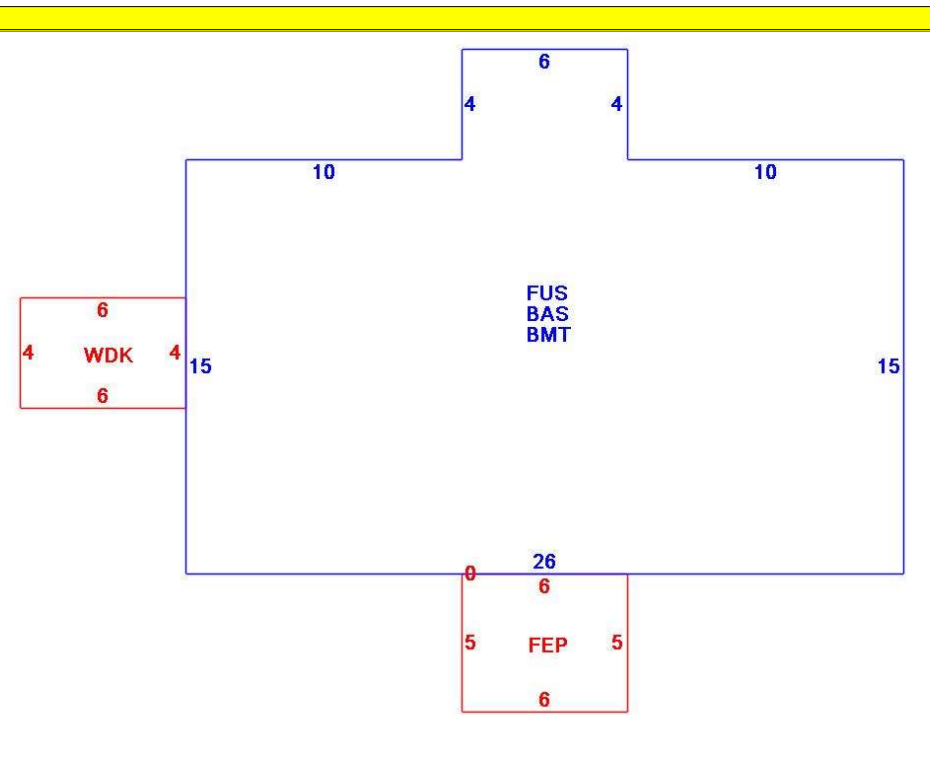

OB - OUTBUILDING & YARD ITEMS(L) / XF - BUILDING EXTRA FEATURES(B)										
Code	Description	L/B	Units	Unit Price	Yr Blt	Cond. Cd	% Gd	Grade	Grade Adj.	Appr. Value
FEP	Enclosed porc	B	30	70.00	1979		69		0.00	2,800
BMT	Basement-Unfi	B	414	26.01	1979		69		0.00	10,100
WDC	Wood Decking	L	24	20.00	1992		46		0.00	800

BUILDING SUB-AREA SUMMARY SECTION						
Code	Description	Living Area	Floor Area	Eff Area	Unit Cost	Undeprec Value
BAS	First Floor	414	414	414	314.76	130,311
BMT	Basement Area	0	414	0	0.00	0
FEP	Enclosed Porch	0	30	0	0.00	0
FUS	Upper Story	414	414	414	314.76	130,311
WDK	Wood Deck	0	24	0	0.00	0
Ttl Gross Liv / Lease Area		828	1,296	828		260,622

