

CURRENT OWNER		TOPO	UTILITIES	STRT / ROAD	LOCATION	CURRENT ASSESSMENT			
SOUTH YARMOUTH SERIES TWO LL PO BOX 342 HYANNIS MA 02601		1 Level	2 Public Water	1 Paved		Description	Code	Assessed	Assessed
			4 Gas			RESIDNTL	1010	326,400	326,400
			6 Septic			RES LAND	1010	135,300	135,300
SUPPLEMENTAL DATA									
		Alt Prcl ID Split Zonin BID Parcel ResExpt Q #DL 1 LOTS 5 & 57 #DL 2 GIS ID F_985502_2702196		Plan Ref. Land Ct# 14034-A & C #SR Life Estate PP STATU Assoc Pid#		Total 461,700 461,700			

801
 FY2024
 BARNSTABLE, MA

VISION

RECORD OF OWNERSHIP		BK-VOL/PAGE	SALE DATE	Q/U	V/I	SALE PRIC	VC	PREVIOUS ASSESSMENTS (HISTORY)						
SOUTH YARMOUTH SERIES TWO LLC		C206768	0	07-07-2015	U	I	100	1F	Year	Code	Assessed	Year	Code	Assessed
JOHNSON, NANCY I		C181728	0	11-30-2006	Q	I	276,000	00	2023	1010	277,100	2022	1010	238,600
CONDON, DIANE		C144302	0	04-30-1997	Q	I	83,000	00		1010	129,800		1010	96,100
BAILEY, DONNA M TR		C126759	0	06-15-1992	U	I	1	F					1010	1,100
BAILEY, DONNA P		C70654	0	05-26-1977	U		0		Total		406,900	Total		334,700
										Total				282,400

EXEMPTIONS			OTHER ASSESSMENTS					
Year	Code	Description	Amount	Code	Description	Number	Amount	Comm Int
Total			0.00					

This signature acknowledges a visit by a Data Collector or Assessor

ASSESSING NEIGHBORHOOD			
Nbhd	Nbhd Name	B	Tracing
0104			Batch HYAN

NOTES			

APPRAISED VALUE SUMMARY			
Appraised Bldg. Value (Card)			310,000
Appraised Xf (B) Value (Bldg)			15,300
Appraised Ob (B) Value (Bldg)			1,100
Appraised Land Value (Bldg)			135,300
Special Land Value			0
Total Appraised Parcel Value			461,700
Valuation Method			C
Total Appraised Parcel Value			461,700

BUILDING PERMIT RECORD								VISIT / CHANGE HISTORY						
Permit Id	Issue Date	Type	Description	Amount	Insp Date	% Comp	Date Comp	Comments	Date	Id	Type	Is	Cd	Purpost/Result
87142	09-26-2005	NW	New Windows	9,000	06-30-2006	100	06-30-2006		05-05-2020	WD			FR	Field Review
									04-10-2018	SR	02		03	Cycl Insp Comp
									06-05-2003	PT	02		01	Meas/Est
									03-06-2001	PT	01		00	Meas/Listed-Interior Acces
									11-15-1987	ML	01		00	Meas/Listed-Interior Acces

LAND LINE VALUATION SECTION																
B	Use Code	Description	Zone	LA	Land Units	Unit Price	Size Adj	AC Disc	Site Index	Cond.	Nbhd.	Nbhd. Adj	Notes	Location Adjustmen	Adj Unit P	Land Value
1	1010	Single Fam M-0	RB	4	0.290	AC	176,344.00	2.93869	1.0000	5	1.00	0104	0.900		1.0000	466,394.6
Total Card Land Units					0.29	AC	Parcel Total Land Area					0.29	Total Land Value			135,300

CONSTRUCTION DETAIL			CONSTRUCTION DETAIL (CONTINUED)		
Element	Cd	Description	Element	Cd	Description
Style	01	Ranch			
Model	01	Residential			
Grade:	C-	Average Minus			
Stories	1	1 Story			
Exterior Wall 1	14	Wood Shingle			
Exterior Wall 2	11	Clapboard			
RooF Structure	03	Gable/Hip			
RooF Cover	03	Asph/F Gls/Cmp			
Interior Wall 1	05	Drywall			
Interior Wall 2					
Interior Floor 1	14	Carpet			
Interior Floor 2					
Heat Fuel	03	Gas			
Heat Type	05	Hot Water			
AC Type	01	None			
Bedrooms	04	4 Bedrooms			
Full Baths	2				
Half Baths	0				
Extra Fixtures					
Total Rooms	7	7 Rooms			
Bath Style					
Kitchen Style					
Occupancy					
UsrflD 105					
Accessory Apt					
Foundation Alt	02	Conc. Block			
Rms Prts					
Bath Split	20	2 Full-0 Half			

CONDO DATA			
Parcel Id		C	Owne 0.0
		B	S
Adjust Type	Code	Description	Factor%
Condo Flr			
Condo Unit			

COST / MARKET VALUATION	
Building Value New	418,912
Year Built	1960
Effective Year Built	1986
Depreciation Code	A
Remodel Rating	
Year Remodeled	
Depreciation %	26
Functional Obsol	0
External Obsol	0
Trend Factor	1
Condition	
Condition %	
Percent Good	74
RCNLD	310,000
Dep % Ovr	
Dep Ovr Comment	
Misc Imp Ovr	
Misc Imp Ovr Comment	
Cost to Cure Ovr	
Cost to Cure Ovr Comment	

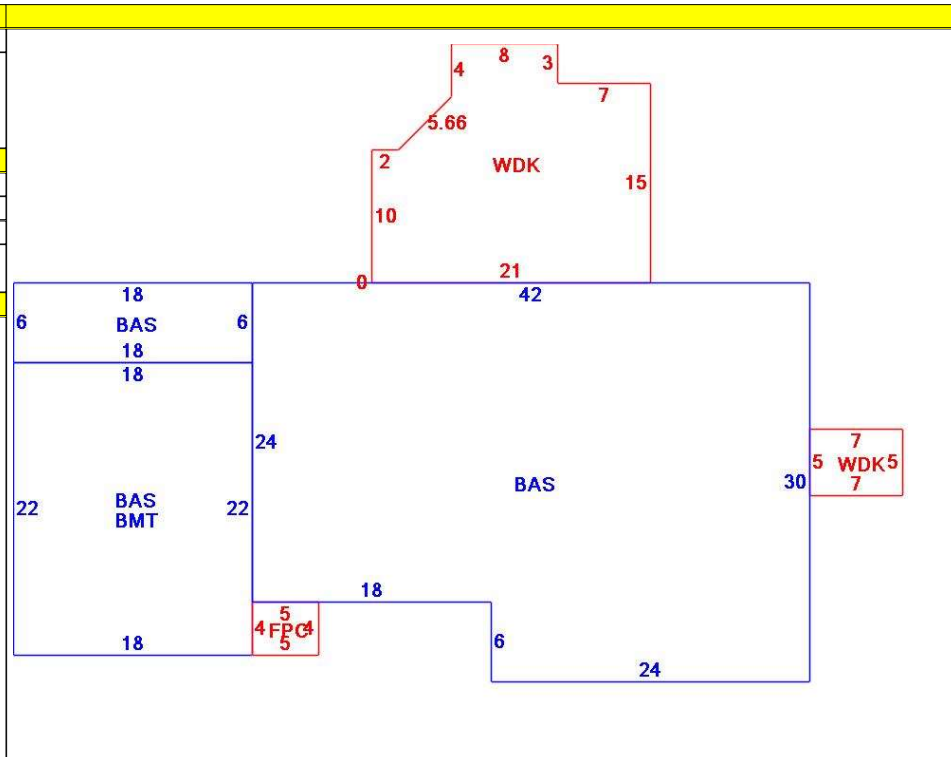

OB - OUTBUILDING & YARD ITEMS(L) / XF - BUILDING EXTRA FEATURES(B)										
Code	Description	L/B	Units	Unit Price	Yr Blt	Cond. Cd	% Gd	Grade	Grade Adj.	Appr. Value
FPL1	Fireplace 1 sto	B	1	5000.00	1988		74		0.00	3,700
WDC	Wood Decking	L	352	20.00	1977		16		0.00	1,100
FOPC	Open Prch-roo	B	20	55.00	1988		74		0.00	1,100
BMT	Basement-Unfi	B	396	26.01	1988		74		0.00	10,500

BUILDING SUB-AREA SUMMARY SECTION						
Code	Description	Living Area	Floor Area	Eff Area	Unit Cost	Undeprec Value
BAS	First Floor	1,656	1,656	1,656	252.97	418,912
BMT	Basement Area	0	396	0	0.00	0
FPC	Open Porch Conc. Floor	0	20	0	0.00	0
WDK	Wood Deck	0	352	0	0.00	0
Ttl Gross Liv / Lease Area		1,656	2,424	1,656		418,912

