

CURRENT OWNER		TOPO	UTILITIES	STRT / ROAD	LOCATION	CURRENT ASSESSMENT			
LAWRENCE, BRIAN HENRY SR & MA LAWRENCE 2019 FAMILY TRUST 110 BACON ROAD HYANNIS MA 02601		1 Level	2 Public Water	1 Paved		Description	Code	Assessed	Assessed
			4 Gas			RESIDNTL	1010	384,400	384,400
			6 Septic			RES LAND	1010	132,000	132,000
SUPPLEMENTAL DATA									
Alt Prcl ID		Split Zonin		Plan Ref.					
BID Parcel		ResExpt Q YES:		Land Ct# 18327-A					
#DL 1 LOTS 59 & 60		#DL 2		#SR					
GIS ID F_986338_2702468		Assoc Pid#		Life Estate					
				PP STATU					
						Total		516,400	516,400

801
 FY2024
 BARNSTABLE, MA

VISION

RECORD OF OWNERSHIP		BK-VOL/PAGE	SALE DATE	Q/U	V/I	SALE PRIC	VC	PREVIOUS ASSESSMENTS (HISTORY)								
ZHANG, SHENG	C233566	0	07-31-2023	Q	I	638,000	00	Year	Code	Assessed	Year	Code	Assessed			
LAWRENCE, BRIAN HENRY SR & MARY	C224029	0	10-13-2020	U	I	100	1F	2023	1010	341,200	2022	1010	290,800			
LAWRENCE, BRIAN H SR & MARY BETH	C155713	0	12-01-1999	Q	I	145,500	00		1010	126,700		1010	93,800			
PETRILLI, DOROTHY M	C154151	0	07-28-1999	U	I	125,000	1A					1010	6,000			
CHASE, DAPHNE R	#D33220	0	04-02-1984	U	I	0	A									
								Total		467,900	Total		384,600	Total		340,400

EXEMPTIONS			OTHER ASSESSMENTS					
Year	Code	Description	Amount	Code	Description	Number	Amount	Comm Int
2014	5C	RESIDENTIAL EXEMPTION	0.00					
Total			0.00					

This signature acknowledges a visit by a Data Collector or Assessor

ASSESSING NEIGHBORHOOD			
Nbhd	Nbhd Name	B	Tracing
0104			HYAN

APPRAISED VALUE SUMMARY	
Appraised Bldg. Value (Card)	341,100
Appraised Xf (B) Value (Bldg)	37,300
Appraised Ob (B) Value (Bldg)	6,000
Appraised Land Value (Bldg)	132,000
Special Land Value	0
Total Appraised Parcel Value	516,400
Valuation Method	C
Total Appraised Parcel Value	516,400

NOTES								

BUILDING PERMIT RECORD									VISIT / CHANGE HISTORY					
Permit Id	Issue Date	Type	Description	Amount	Insp Date	% Comp	Date Comp	Comments	Date	Id	Type	Is	Cd	Purpost/Result
201206420	10-25-2012	IN	Insulation	5,800	06-30-2013	100	06-30-2013	INSULATE	05-05-2020	WD			FR	Field Review
56809	10-23-2001	NS	New Siding	2,000	01-01-2002	100	06-30-2002	STRIP & RESIDE	10-27-2017	SR	02		03	Cycl Insp Comp
									06-24-2014	GC	03		16	In Office Review
									06-20-2014	JR	03		16	In Office Review
									06-10-2003	PT	02		01	Meas/Est
									05-13-2002	MF	04		44	Drive by inspection only
									03-12-2001	PT	01		00	Meas/Listed-Interior Acces

LAND LINE VALUATION SECTION																	
B	Use Code	Description	Zone	LA	Land Units	Unit Price	Size Adj	AC Disc	Site Index	Cond.	Nbhd.	Nbhd. Adj	Notes	Location Adjustmen	Adj Unit P	Land Value	
1	1010	Single Fam M-0	RB	4	0.230	AC	176,344.00	3.61599	1.0000	5	1.00	0104	0.900		1.0000	573,893.9	132,000
Total Card Land Units					0.23	AC	Parcel Total Land Area					0.23	Total Land Value				132,000

CONSTRUCTION DETAIL			CONSTRUCTION DETAIL (CONTINUED)		
Element	Cd	Description	Element	Cd	Description
Style	04	Cape Cod			
Model	01	Residential			
Grade:	C	Average			
Stories	1.75	1 3/4 Stories			
Exterior Wall 1	25	Vinyl Siding			
Exterior Wall 2					
Roof Structure	03	Gable/Hip			
Roof Cover	03	Asph/F Gls/Cmp			
Interior Wall 1	05	Drywall			
Interior Wall 2					
Interior Floor 1	14	Carpet			
Interior Floor 2					
Heat Fuel	03	Gas			
Heat Type	05	Hot Water			
AC Type	01	None			
Bedrooms	02	2 Bedrooms			
Full Baths	1				
Half Baths	1				
Extra Fixtures					
Total Rooms	6	6 Rooms			
Bath Style					
Kitchen Style					
Occupancy					
Usrflid 105					
Accessory Apt					
Foundation Alt	01	Poured Conc.			
Rms Prts					
Bath Split	11	1 Full-1 Half			

CONDO DATA			
Parcel Id		C	Ownr 0.0
Adjust Type	Code	Description	Factor%
Condo Flr			
Condo Unit			

COST / MARKET VALUATION	
Building Value New	454,742
Year Built	1962
Effective Year Built	1987
Depreciation Code	A
Remodel Rating	
Year Remodeled	
Depreciation %	25
Functional Obsol	0
External Obsol	0
Trend Factor	1
Condition	
Condition %	
Percent Good	75
RCNLD	341,100
Dep % Ovr	
Dep Ovr Comment	
Misc Imp Ovr	
Misc Imp Ovr Comment	
Cost to Cure Ovr	
Cost to Cure Ovr Comment	

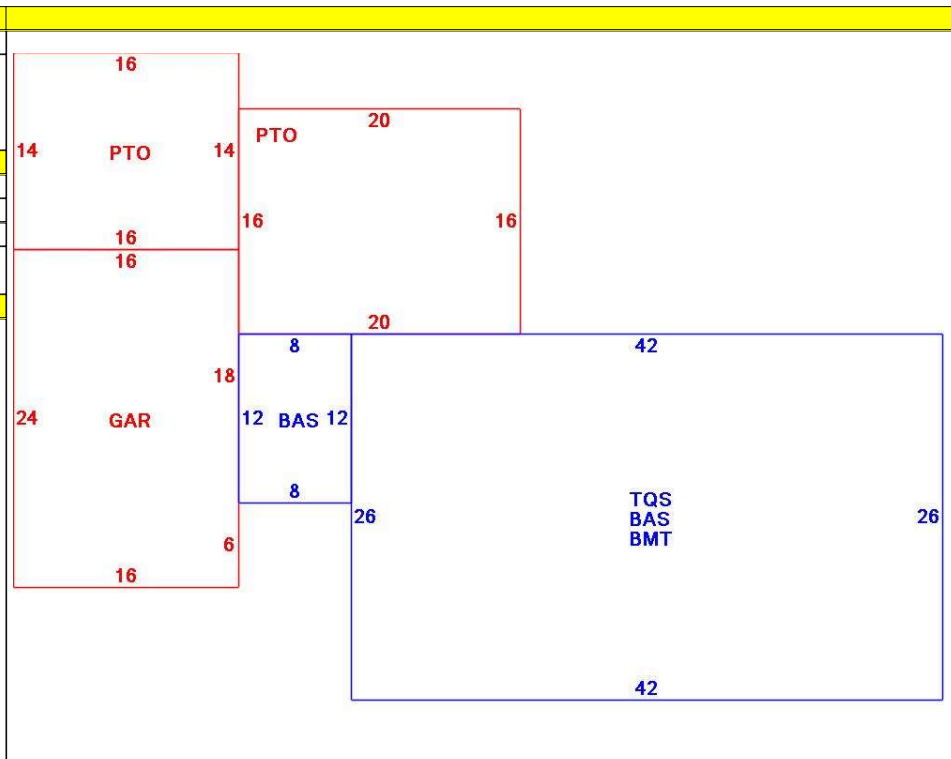

OB - OUTBUILDING & YARD ITEMS(L) / XF - BUILDING EXTRA FEATURES(B)										
Code	Description	L/B	Units	Unit Price	Yr Blt	Cond. Cd	% Gd	Grade	Grade Adj.	Appr. Value
FPL2	Fireplace 1.5 s	B	1	6000.00	1989		75		0.00	4,500
PATC	Conc Pavers	L	544	15.46	1993		74		0.00	6,000
GAR	Attached Gara	B	384	40.00	1989		75		0.00	11,700
BMT	Basement-Unfi	B	1,092	26.01	1989		75		0.00	21,100

BUILDING SUB-AREA SUMMARY SECTION						
Code	Description	Living Area	Floor Area	Eff Area	Unit Cost	Undeprec Value
BAS	First Floor	1,188	1,188	1,188	239.59	284,633
BMT	Basement Area	0	1,092	0	0.00	0
GAR	Attached Garage	0	384	0	0.00	0
PTO	Patio	0	544	0	0.00	0
TQS	Three Quarter Story	710	1,092	710	155.78	170,109
Ttl Gross Liv / Lease Area		1,898	4,300	1,898		454,742

