

| CURRENT OWNER | | | | TOPO | UTILITIES | STRT / ROAD | LOCATION | CURRENT ASSESSMENT | | | | |
|-------------------------------|--|--|--|------|-----------|------------------|----------|--------------------|------|----------|----------|---------------------------------|
| GUERRA, ARTHUR V & BAHRAWY, A | | | | | | | | Description | Code | Assessed | Assessed | 801 FY2024 BARNSTABLE, MA |
| 832 PUTNAM AVENUE | | | | | | | | RESIDNTL | 1010 | 292,900 | 292,900 | |
| COTUIT MA 02635 | | | | | | | | RES LAND | 1010 | 156,500 | 156,500 | |
| SUPPLEMENTAL DATA | | | | | | | | | | | | VISION |
| Alt Prcl ID | | | | | | Plan Ref. | | | | | | |
| Split Zonin | | | | | | Land Ct# 36319-B | | | | | | |
| BID Parcel | | | | | | #SR | | | | | | |
| ResExpt Q | | | | | | Life Estate | | | | | | |
| #DL 1 LOT 10 | | | | | | PP STATU | | | | | | |
| #DL 2 | | | | | | Assoc Pid# | | | | | | |
| GIS ID F_949311_2696619 | | | | | | | | Total | | 449,400 | 449,400 | |

| RECORD OF OWNERSHIP | | | | BK-VOL/PAGE | SALE DATE | Q/U | V/I | SALE PRIC | VC | PREVIOUS ASSESSMENTS (HISTORY) | | | | | | | | | |
|----------------------------------|--|--|--|-------------|-----------|------------|-----|-----------|---------|--------------------------------|-------|------|----------|-------|------|----------|------|------|----------|
| GUERRA, ARTHUR V & BAHRAWY, ALEX | | | | C226575 | 0 | 06-10-2021 | U | I | 415,000 | 1 | Year | Code | Assessed | Year | Code | Assessed | Year | Code | Assessed |
| PROUTY, GERTRUDE M ESTATE OF | | | | 1,431,114 | 0 | 04-10-2019 | U | I | 0 | 1F | 2023 | 1010 | 245,000 | 2022 | 1010 | 213,500 | 2021 | 1010 | 176,200 |
| PROUTY, GERTRUDE M | | | | D550689 | 0 | 04-21-1992 | U | V | 0 | | | 1010 | 142,300 | | 1010 | 105,400 | | 1010 | 105,400 |
| PROUTY, DONALD & GERTRUDE M | | | | C99400 | 0 | 12-15-1984 | Q | I | 69,000 | U | | | | | | | | | |
| FULLER, ROBERT W & MEBL E | | | | C65702 | 0 | 10-21-1975 | U | | 0 | | | | | | | | | | |
| | | | | | | | | Total | | 387,300 | Total | | 318,900 | Total | | 281,600 | | | |

| EXEMPTIONS | | | | OTHER ASSESSMENTS | | | | This signature acknowledges a visit by a Data Collector or Assessor | | | | | | | | | | | | |
|------------|------|-------------|--------|-------------------|-------------|--------|--------|---|--|--|--|--|--|--|--|--|--|--|--|--|
| Year | Code | Description | Amount | Code | Description | Number | Amount | Comm Int | | | | | | | | | | | | |
| | | | | | | | | | | | | | | | | | | | | |
| | | | Total | 0.00 | | | | | | | | | | | | | | | | |

| ASSESSING NEIGHBORHOOD | | | | APPRAISED VALUE SUMMARY | | | | |
|------------------------|-----------|---|---------|-------------------------|--|--|--|--|
| Nbhd | Nbhd Name | B | Tracing | Batch | | | | |
| 0105 | | | COTUIT | | | | | |

| NOTES | | | | | | | | | | | | APPRAISED VALUE SUMMARY | | | |
|-------|--|--|--|--|--|--|--|--|--|--|--|-------------------------------|---------|--|--|
| | | | | | | | | | | | | Appraised Bldg. Value (Card) | 245,700 | | |
| | | | | | | | | | | | | Appraised Xf (B) Value (Bldg) | 47,200 | | |
| | | | | | | | | | | | | Appraised Ob (B) Value (Bldg) | 0 | | |
| | | | | | | | | | | | | Appraised Land Value (Bldg) | 156,500 | | |
| | | | | | | | | | | | | Special Land Value | 0 | | |
| | | | | | | | | | | | | Total Appraised Parcel Value | 449,400 | | |
| | | | | | | | | | | | | Valuation Method | C | | |
| | | | | | | | | | | | | Total Appraised Parcel Value | 449,400 | | |

| BUILDING PERMIT RECORD | | | | | | | | | VISIT / CHANGE HISTORY | | | | | |
|------------------------|------------|------|-------------|--------|------------|--------|------------|----------------------|------------------------|----|------|----|----|------------------|
| Permit Id | Issue Date | Type | Description | Amount | Insp Date | % Comp | Date Comp | Comments | Date | Id | Type | Is | Cd | Purpost/Result |
| 16-3555 | 12-02-2016 | 822 | Insulation | 4,200 | 06-30-2017 | 100 | 06-30-2017 | weatherization | 11-10-2022 | SR | 02 | | 03 | Cycl Insp Comp |
| 201201628 | 03-22-2012 | NR | New Roof | 6,800 | 06-30-2012 | 100 | 06-30-2012 | REROOF STRIPPING OLD | 06-22-2020 | PK | 03 | | 16 | In Office Review |
| B17694 | 05-01-1975 | DW | Dwelling | 0 | 01-15-1976 | 100 | 06-30-1976 | CO 1 ST | 06-10-2020 | WD | | | FR | Field Review |
| | | | | | | | | | 03-10-2015 | SR | 01 | | 03 | Cycl Insp Comp |
| | | | | | | | | | 06-29-2005 | PT | 02 | | 01 | Meas/Est |
| | | | | | | | | | 09-17-2002 | PT | 02 | | 01 | Meas/Est |
| | | | | | | | | | 06-02-1997 | JG | 02 | | 01 | Meas/Est |

| LAND LINE VALUATION SECTION | | | | | | | | | | | | | | | | | |
|-----------------------------|----------|----------------|------|----|------------|------------|------------------------|---------|------------|-------|-------|-----------|------------------|--------------------|------------|------------|---------|
| B | Use Code | Description | Zone | LA | Land Units | Unit Price | Size Adj | AC Disc | Site Index | Cond. | Nbhd. | Nbhd. Adj | Notes | Location Adjustmen | Adj Unit P | Land Value | |
| 1 | 1010 | Single Fam M-0 | RF | 2 | 0.480 | AC | 176,344.00 | 1.84893 | 1.0000 | 5 | 1.00 | 0105 | 1.000 | | 1.0000 | 326,042.4 | 156,500 |
| Total Card Land Units | | | | | 0.48 | AC | Parcel Total Land Area | | | | | 0.48 | Total Land Value | | | 156,500 | |

| CONSTRUCTION DETAIL | | | CONSTRUCTION DETAIL (CONTINUED) | | |
|---------------------|----|----------------|---------------------------------|------|-------------|
| Element | Cd | Description | Element | Cd | Description |
| Style | 01 | Ranch | | | |
| Model | 01 | Residential | | | |
| Grade: | C | Average | | | |
| Stories | 1 | 1 Story | | | |
| Exterior Wall 1 | 14 | Wood Shingle | | | |
| Exterior Wall 2 | 11 | Clapboard | | | |
| Roof Structure | 03 | Gable/Hip | | | |
| Roof Cover | 03 | Asph/F Gls/Cmp | | | |
| Interior Wall 1 | 05 | Drywall | | | |
| Interior Wall 2 | | | | | |
| Interior Floor 1 | 12 | Hardwood | | | |
| Interior Floor 2 | | | | | |
| Heat Fuel | 03 | Gas | | | |
| Heat Type | 04 | Hot Air | | | |
| AC Type | 03 | Central | | | |
| Bedrooms | 02 | 2 Bedrooms | | | |
| Full Baths | 1 | | | | |
| Half Baths | 0 | | | | |
| Extra Fixtures | | | | | |
| Total Rooms | 4 | 4 Rooms | | | |
| Bath Style | | | | | |
| Kitchen Style | | | | | |
| Occupancy | | | | | |
| Usrflid 105 | | | | | |
| Accessory Apt | | | | | |
| Foundation Alt | 01 | Poured Conc. | | | |
| Rms Prts | | | | | |
| Bath Split | 10 | 1 Full-0 Half | | | |
| | | | CONDO DATA | | |
| | | | Parcel Id | C | Ownr 0.0 |
| | | | Adjust Type | Code | Description |
| | | | Condo Flr | | Factor% |
| | | | Condo Unit | | |
| | | | COST / MARKET VALUATION | | |
| | | | Building Value New | | 307,090 |
| | | | Year Built | | 1975 |
| | | | Effective Year Built | | 1993 |
| | | | Depreciation Code | | A |
| | | | Remodel Rating | | |
| | | | Year Remodeled | | |
| | | | Depreciation % | | 20 |
| | | | Functional Obsol | | 0 |
| | | | External Obsol | | 0 |
| | | | Trend Factor | | 1 |
| | | | Condition | | |
| | | | Condition % | | |
| | | | Percent Good | | 80 |
| | | | RCNLD | | 245,700 |
| | | | Dep % Ovr | | |
| | | | Dep Ovr Comment | | |
| | | | Misc Imp Ovr | | |
| | | | Misc Imp Ovr Comment | | |
| | | | Cost to Cure Ovr | | |
| | | | Cost to Cure Ovr Comment | | |

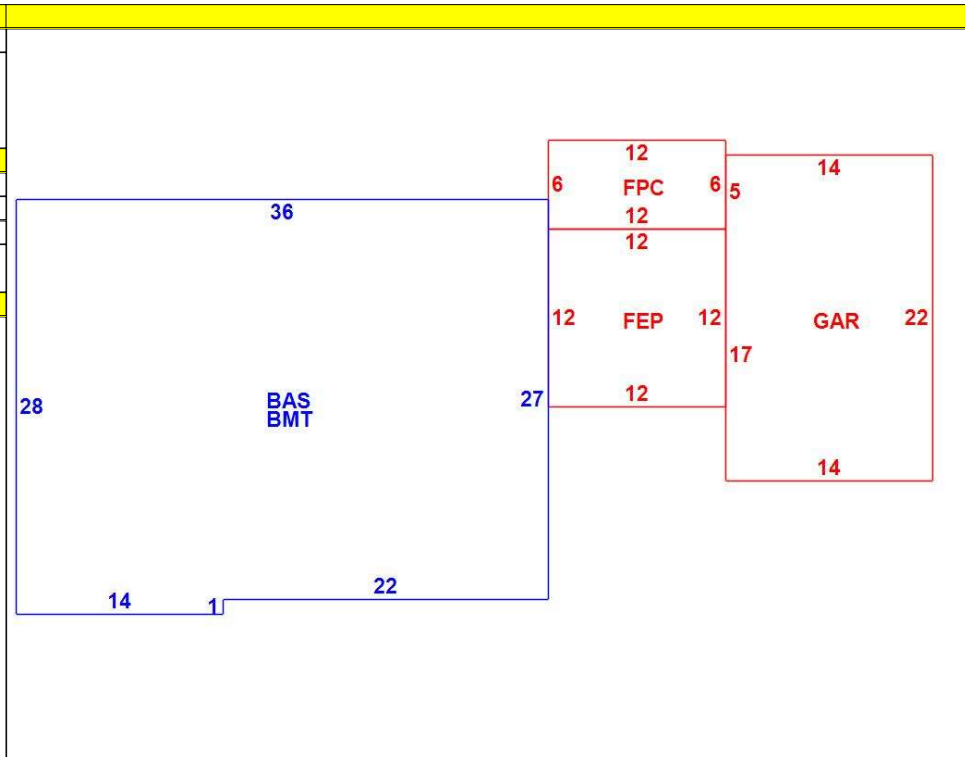

| OB - OUTBUILDING & YARD ITEMS(L) / XF - BUILDING EXTRA FEATURES(B) | | | | | | | | | | |
|--|-----------------|-----|-------|------------|--------|----------|------|-------|------------|-------------|
| Code | Description | L/B | Units | Unit Price | Yr Blt | Cond. Cd | % Gd | Grade | Grade Adj. | Appr. Value |
| FPL1 | Fireplace 1 sto | B | 1 | 5000.00 | 1995 | | 80 | | 0.00 | 4,000 |
| FOPC | Open Prch-roo | B | 72 | 55.00 | 1995 | | 80 | | 0.00 | 3,000 |
| FEP | Enclosed porc | B | 144 | 70.00 | 1995 | | 80 | | 0.00 | 8,200 |
| GAR | Attached Gara | B | 308 | 40.00 | 1995 | | 80 | | 0.00 | 10,900 |
| BMT | Basement-Unfi | B | 986 | 26.01 | 1995 | | 80 | | 0.00 | 21,100 |

| BUILDING SUB-AREA SUMMARY SECTION | | | | | | |
|-----------------------------------|------------------------|-------------|------------|----------|-----------|----------------|
| Code | Description | Living Area | Floor Area | Eff Area | Unit Cost | Undeprec Value |
| BAS | First Floor | 986 | 986 | 986 | 311.45 | 307,090 |
| BMT | Basement Area | 0 | 986 | 0 | 0.00 | 0 |
| FEP | Enclosed Porch | 0 | 144 | 0 | 0.00 | 0 |
| FPC | Open Porch Conc. Floor | 0 | 72 | 0 | 0.00 | 0 |
| GAR | Attached Garage | 0 | 308 | 0 | 0.00 | 0 |
| Ttl Gross Liv / Lease Area | | 986 | 2,496 | 986 | | 307,090 |

