

CURRENT OWNER		TOPO	UTILITIES	STRT / ROAD	LOCATION	CURRENT ASSESSMENT				801 FY2024 BARNSTABLE, MA  <b>VISION</b>
TWENTY LOCUST LLC  6 CATLIN ROAD  WALLINGFORD CT 06492		1 Level	2 Public Water	1 Paved		Description	Code	Assessed	Assessed	
			4 Gas			RESIDNTL	1010	291,100	291,100	
			6 Septic			RES LAND	1010	131,000	131,000	
<b>SUPPLEMENTAL DATA</b>						Total				422,100
Alt Prcl ID Split Zonin BID Parcel ResExpt Q #DL 1 LOTS 6 & 7 #DL 2 BLOCK A GIS ID F_987541_2702326				Plan Ref. 14/41 Land Ct# #SR Life Estate PP STATU Assoc Pid#						

RECORD OF OWNERSHIP		BK-VOL/PAGE	SALE DATE	Q/U	V/I	SALE PRIC	VC	PREVIOUS ASSESSMENTS (HISTORY)					
TWENTY LOCUST LLC		35504 016	11-25-2022	U	I	1	1F	Year	Code	Assessed	Year	Code	Assessed
REYNOLDS, JESSICA		35423 153	10-14-2022	Q	I	475,000	00	2023	1010	237,100	2022	1010	204,700
KOGOS, FAYE M		34931 166	02-25-2022	U	I	400,000	1		1010	125,700		1010	93,100
MITCHELL, BARBARA J		22003 0118	05-07-2007	U	I	0	1			0		1010	3,200
MITCHELL, LAURENCE E & BARBARA J		4442 0243	03-15-1985	U	V	61,000	D	Total		362,800	Total		297,800
								Total			Total		254,500

EXEMPTIONS			OTHER ASSESSMENTS				This signature acknowledges a visit by a Data Collector or Assessor								
Year	Code	Description	Amount	Code	Description	Number	Amount	Comm Int							
Total			0.00												

ASSESSING NEIGHBORHOOD				APPRaised VALUE SUMMARY				
Nbhd	Nbhd Name	B	Tracing	Batch				
0104				HYAN	Appraised Bldg. Value (Card)			255,200
					Appraised Xf (B) Value (Bldg)			32,700
					Appraised Ob (B) Value (Bldg)			3,200
					Appraised Land Value (Bldg)			131,000
					Special Land Value			0
					Total Appraised Parcel Value			422,100
					Valuation Method			C
					Total Appraised Parcel Value			422,100

NOTES								VISIT / CHANGE HISTORY							
Permit Id	Issue Date	Type	Description	Amount	Insp Date	% Comp	Date Comp	Comments	Date	Id	Type	Is	Cd	Purpost/Result	
EXPR-23-1	01-03-2023	835	Sid/Wind/Roof/	3,194		100		INSULATION/WEATHERIZATI 6X12 BAS	05-19-2023	LP			20	Sale Review	
200700286	01-30-2007	AD	Addition	20,000	12-11-2007	100	06-30-2008		05-05-2020	WD				FR	Field Review
67179	04-25-2003	AD	Addition	24,500	06-30-2003	100	01-01-2004		10-24-2017	KM	02			03	Cycl Insp Comp
									12-11-2007	PT	02			14	Cyclical Inspection
									06-30-2003	MF	02			02	Bldg Permit Completed

LAND LINE VALUATION SECTION																	
B	Use Code	Description	Zone	LA	Land Units	Unit Price	Size Adj	AC Disc	Site Index	Cond.	Nbhd.	Nbhd. Adj	Notes	Location Adjustmen	Adj Unit P	Land Value	
1	1010	Single Fam M-0	RB	4	0.220	AC	176,344.00	3.75053	1.0000	5	1.00	0104	0.900		1.0000	595,249.1	131,000
Total Card Land Units					0.22	AC	Parcel Total Land Area					0.22	Total Land Value			131,000	

CONSTRUCTION DETAIL			CONSTRUCTION DETAIL (CONTINUED)		
Element	Cd	Description	Element	Cd	Description
Style	01	Ranch			
Model	01	Residential			
Grade:	C	Average			
Stories	1	1 Story			
Exterior Wall 1	25	Vinyl Siding			
Exterior Wall 2					
RooF Structure	03	Gable/Hip			
RooF Cover	03	Asph/F Gls/Cmp			
Interior Wall 1	05	Drywall			
Interior Wall 2					
Interior Floor 1	14	Carpet			
Interior Floor 2	12	Hardwood			
Heat Fuel	02	Oil			
Heat Type	05	Hot Water			
AC Type	01	None			
Bedrooms	02	2 Bedrooms			
Full Baths	1				
Half Baths	0				
Extra Fixtures					
Total Rooms	6	6 Rooms			
Bath Style					
Kitchen Style					
Occupancy					
Usrflid 105					
Accessory Apt					
Foundation Alt	02	Conc. Block			
Rms Prts					
Bath Split	10	1 Full-0 Half			
			<b>CONDO DATA</b>		
			Parcel Id	C	Owne 0.0
			Adjust Type	Code	Description
			Condo Flr		
			Condo Unit		
			<b>COST / MARKET VALUATION</b>		
			Building Value New 349,594		
			Year Built 1940		
			Effective Year Built 1984		
			Depreciation Code G		
			Remodel Rating		
			Year Remodeled		
			Depreciation % 27		
			Functional Obsol 0		
			External Obsol 0		
			Trend Factor 1		
			Condition		
			Condition %		
			Percent Good 73		
			RCNLD 255,200		
			Dep % Ovr		
			Dep Ovr Comment		
			Misc Imp Ovr		
			Misc Imp Ovr Comment		
			Cost to Cure Ovr		
			Cost to Cure Ovr Comment		

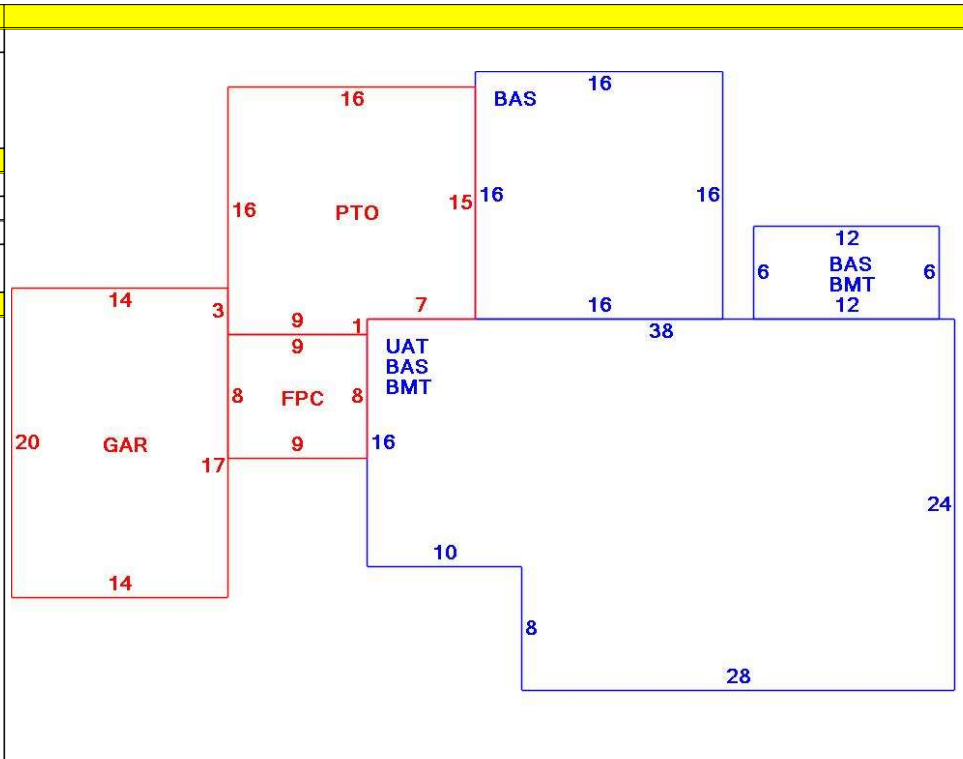

OB - OUTBUILDING & YARD ITEMS(L) / XF - BUILDING EXTRA FEATURES(B)										
Code	Description	L/B	Units	Unit Price	Yr Blt	Cond. Cd	% Gd	Grade	Grade Adj.	Appr. Value
FPL1	Fireplace 1 sto	B	1	5000.00	1979		73		0.00	3,700
PAT2	Patio-Good	L	249	9.94	1989		70		0.00	1,800
FOPC	Open Prch-roo	B	72	55.00	1979		73		0.00	2,700
GAR	Attached Gara	B	280	40.00	1979		73		0.00	9,300
BMT	Basement-Unfi	B	832	26.01	1979		73		0.00	17,000
SHED	Shed	L	80	18.00	2017		96		0.00	1,400

BUILDING SUB-AREA SUMMARY SECTION						
Code	Description	Living Area	Floor Area	Eff Area	Unit Cost	Undeprec Value
BAS	First Floor	1,160	1,160	1,160	281.25	326,250
BMT	Basement Area	0	904	0	0.00	0
FPC	Open Porch Conc. Floor	0	72	0	0.00	0
GAR	Attached Garage	0	280	0	0.00	0
PTO	Patio	0	249	0	0.00	0
UAT	Attic, Unfinished	0	832	83	28.06	23,344
Ttl Gross Liv / Lease Area		1,160	3,497	1,243		349,594

