

CURRENT OWNER		TOPO	UTILITIES	STRT / ROAD	LOCATION	CURRENT ASSESSMENT						801 FY2024 BARNSTABLE, MA  <b>VISION</b>								
BROOKE, DIANE A TR STEVEN WINTER TRUST P O BOX 1142  OSTERVILLE MA 02655						Description	Code	Assessed	Assessed											
		<b>SUPPLEMENTAL DATA</b>				RESIDNTL	1020	211,400	211,400											
		Alt Prcl ID	Split Zonin	BID Parcel	ResExpt Q	#DL 1	UNIT 3	#DL 2	GIS ID	F_987613_2701460	Plan Ref.	Land Ct#	20041-A LOT A	#SR	Life Estate	PP STATU	Assoc Pid#	Total	211,400	211,400
RECORD OF OWNERSHIP		BK-VOL/PAGE	SALE DATE	Q/U	V/I	SALE PRICE	VC	PREVIOUS ASSESSMENTS (HISTORY)												
BROOKE, DIANE A TR		C132-0	03-15-1990	U	I	90,000	1	Year	Code	Assessed	Year	Code	Assessed V	Year	Code	Assessed				
DAVENPORT, LEONARD E TR		C132-0	11-15-1985	U	I	0		2023	1020	179,100	2022	1020	151,200	2021	1020	152,900				
BRISS, RAMONA		C132-0	04-15-1982	Q	I	53,334	U													
		Total						179,100		Total		151,200		Total		152,900				
EXEMPTIONS			OTHER ASSESSMENTS				This signature acknowledges a visit by a Data Collector or Assessor													
Year	Code	Description	Amount	Code	Description	Number	Amount	Comm Int												
		Total	0.00																	
ASSESSING NEIGHBORHOOD						APPRAISED VALUE SUMMARY														
Nbhd	Nbhd Name	B	Tracing	Batch																
0001				HYAN																
NOTES																				
BUILDING PERMIT RECORD												VISIT / CHANGE HISTORY								
Permit Id	Issue Date	Type	Description	Amount	Insp Date	% Comp	Date Comp	Comments	Date	Id	Type	Is	Cd	Purpost/Result						
									05-05-2020	WD			FR	Field Review						
									10-29-2018	SR	02		03	Cycl Insp Comp						
									07-31-2015	TP	03		16	In Office Review						
									11-21-2013	TP	03		16	In Office Review						
									12-15-1987	ME	02		01	Meas/Est						
LAND LINE VALUATION SECTION																				
B	Use Code	Description	Zone	Dist	Land Type	Land Units	Unit Price	Size Adj	Site Index	Cond.	Nbhd.	Nbhd. Adj	Notes	Location Adjustmen	Adj Unit P	Land Value				
1	102U	Condominium M	DV	4		0 SF	0.00	1.00000	5	1.00	0001	1.000		0.0000	0	0				
Total Card Land Units						0 SF	Parcel Total Land Area						0.00	Total Land Value				0		

CONSTRUCTION DETAIL			CONSTRUCTION DETAIL (CONTINUED)		
Element	Cd	Description	Element	Cd	Description
Style	55	Condominium			
Model	05	Res Condo			
Bedrm Func	C	Average			
Stories	1.5	1 1/2 Stories			
Occupancy	0				
Interior Wall 1	05	Drywall			
Interior Wall 2					
Interior Floor 1	14	Carpet			
Interior Floor 2	09	Pine/Soft Wood			
Heat Fuel	03	Gas			
Heat Type	04	Hot Air			
AC Type	01	None			
Bedrooms	02	2 Bedrooms			
Full Baths	2	2 Full			
Half Baths	0				
Extra Fixtures					
Total Rooms	4	4 Rooms			
Bath Style					
Kitchen Style					
Master Deed L	950				
Bath Split	20	2 Full-0 Half			
Foundation	01	Poured Conc.			
AC Type Alt					
Sewer Occupan					
<b>CONDO DATA</b>					
Parcel Id	104223	C 0160	Ownr	20.	
	WINTERSET WEST	B 1	S 1		
Adjust Type	Code	Description	Factor%		
Condo Flr			100		
Condo Unit	MKT0	MKT0	100		
<b>COST / MARKET VALUATION</b>					
Building Value New		227,535			
Year Built		1982			
Effective Year Built		2000			
Depreciation Code		A			
Remodel Rating					
Year Remodeled		15			
Depreciation %		0			
Functional Obsol		0			
External Obsol		0			
Trend Factor		1			
Condition					
Condition %		85			
Percent Good		193,400			
Cns Sect Rcnd					
Dep % Ovr					
Dep Ovr Comment					
Misc Imp Ovr					
Misc Imp Ovr Comment					
Cost to Cure Ovr					
Cost to Cure Ovr Comment					

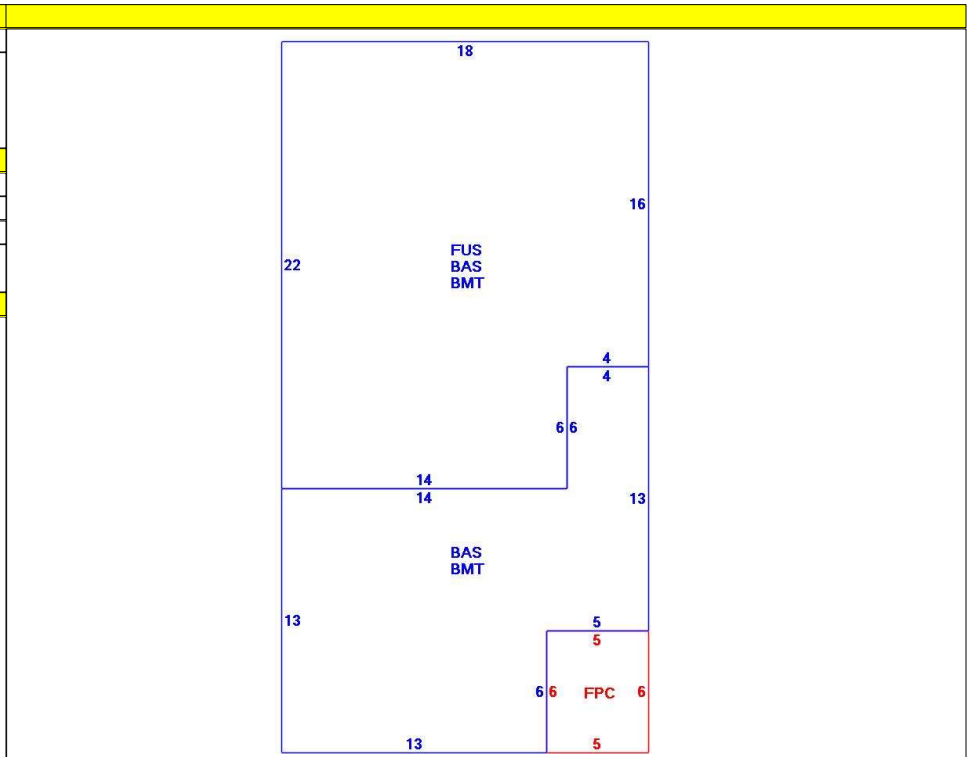

OB - OUTBUILDING & YARD ITEMS(L) / XF - BUILDING EXTRA FEATURES(B)										
Code	Description	L/B	Units	Unit Price	Yr Blt	Cond. Cd	% Gd	Grade	Grade Adj.	Appr. Value
BMT	Basement-Unfi	B	600	26.01	2002		85		0.00	16,300
FOPC	Open Prch-roo	B	30	55.00	2002		85		0.00	1,700

BUILDING SUB-AREA SUMMARY SECTION						
Code	Description	Living Area	Floor Area	Eff Area	Unit Cost	Undeprec Value
BAS	First Floor	600	600	600	234.09	140,454
BMT	Basement Area	0	600	0	0.00	0
FPC	Open Porch Conc. Floor	0	30	0	0.00	0
FUS	Upper Story	372	372	372	234.09	87,081
Ttl Gross Liv / Lease Area		972	1,602	972		227,535

