

CONSTRUCTION DETAIL			CONSTRUCTION DETAIL (CONTINUED)		
Element	Cd	Description	Element	Cd	Description
Style	01	Ranch			
Model	01	Residential			
Grade:	C-	Average Minus			
Stories	1	1 Story			
Exterior Wall 1	14	Wood Shingle	CONDO DATA		
Exterior Wall 2	25	Vinyl Siding	Parcel Id		C
RooF Structure	03	Gable/Hip			B
RooF Cover	03	Asph/F Gls/Cmp			S
Interior Wall 1	05	Drywall	Adjust Type	Code	Description
Interior Wall 2			Condo Flr		
Interior Floor 1	14	Carpet	Condo Unit		
Interior Floor 2			COST / MARKET VALUATION		
Heat Fuel	03	Gas	Building Value New		264,075
Heat Type	05	Hot Water	Year Built		1960
AC Type	01	None	Effective Year Built		1991
Bedrooms	02	2 Bedrooms	Depreciation Code		G
Full Baths	1		Remodel Rating		
Half Baths	0		Year Remodeled		
Extra Fixtures			Depreciation %		22
Total Rooms	4	4 Rooms	Functional Obsol		0
Bath Style			External Obsol		0
Kitchen Style			Trend Factor		1
Occupancy			Condition		
Usrflid 105			Condition %		
Accessory Apt			Percent Good		78
Foundation Alt	02	Conc. Block	RCNLD		206,000
Rms Prts			Dep % Ovr		
Bath Split	10	1 Full-0 Half	Dep Ovr Comment		
			Misc Imp Ovr		
			Misc Imp Ovr Comment		
			Cost to Cure Ovr		
			Cost to Cure Ovr Comment		

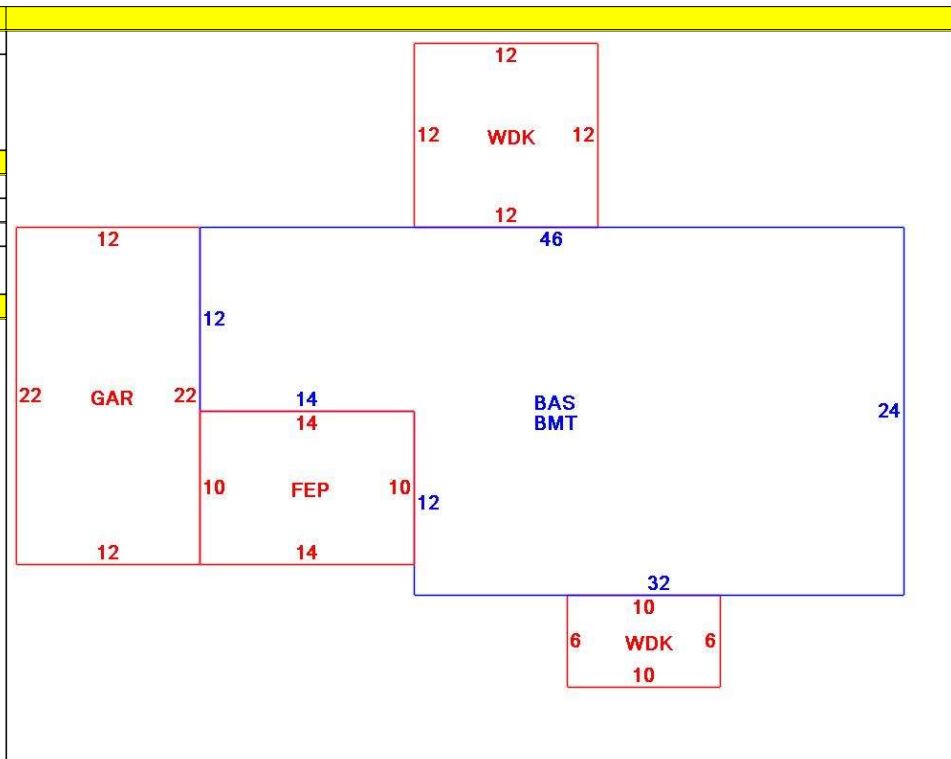

OB - OUTBUILDING & YARD ITEMS(L) / XF - BUILDING EXTRA FEATURES(B)										
Code	Description	L/B	Units	Unit Price	Yr Blt	Cond. Cd	% Gd	Grade	Grade Adj.	Appr. Value
FPL1	Fireplace 1 sto	B	1	5000.00	1993		78		0.00	3,900
FEP	Enclosed porc	B	140	70.00	1993		78		0.00	7,900
GAR	Attached Gara	B	264	40.00	1993		78		0.00	9,500
BMT	Basement-Unfi	B	936	26.01	1993		78		0.00	19,800
WDC	Wood Decking	L	144	20.00	2017		96		0.00	3,900
WDC	Deck comp w	L	60	28.00	2017		96		0.00	4,200

BUILDING SUB-AREA SUMMARY SECTION						
Code	Description	Living Area	Floor Area	Eff Area	Unit Cost	Undeprec Value
BAS	First Floor	936	936	936	282.13	264,075
BMT	Basement Area	0	936	0	0.00	0
FEP	Enclosed Porch	0	140	0	0.00	0
GAR	Attached Garage	0	264	0	0.00	0
WDC	Wood Deck	0	204	0	0.00	0
Ttl Gross Liv / Lease Area		936	2,480	936		264,075

