

CONSTRUCTION DETAIL			CONSTRUCTION DETAIL (CONTINUED)		
Element	Cd	Description	Element	Cd	Description
Style	01	Ranch			
Model	01	Residential			
Grade:	C+	Average Plus			
Stories	1	1 Story			
Exterior Wall 1	14	Wood Shingle			
Exterior Wall 2					
RooF Structure	03	Gable/Hip			
RooF Cover	03	Asph/F Gls/Cmp			
Interior Wall 1	03	Plastered			
Interior Wall 2					
Interior Floor 1	12	Hardwood			
Interior Floor 2	11	Ceram Clay Til			
Heat Fuel	03	Gas			
Heat Type	04	Hot Air			
AC Type	03	Central			
Bedrooms	03	3 Bedrooms			
Full Baths	2				
Half Baths	0				
Extra Fixtures					
Total Rooms	6	6 Rooms			
Bath Style					
Kitchen Style					
Occupancy					
Usrflid 105					
Accessory Apt					
Foundation Alt	01	Poured Conc.			
Rms Prts					
Bath Split	20	2 Full-0 Half			

CONDO DATA				
Parcel Id	C	B	S	Owne 0.0
Adjust Type	Code	Description	Factor%	
Condo Flr				
Condo Unit				

COST / MARKET VALUATION	
Building Value New	605,930
Year Built	1984
Effective Year Built	1998
Depreciation Code	A
Remodel Rating	
Year Remodeled	
Depreciation %	16
Functional Obsol	0
External Obsol	0
Trend Factor	1
Condition	
Condition %	
Percent Good	84
RCNLD	509,000
Dep % Ovr	
Dep Ovr Comment	
Misc Imp Ovr	
Misc Imp Ovr Comment	
Cost to Cure Ovr	
Cost to Cure Ovr Comment	

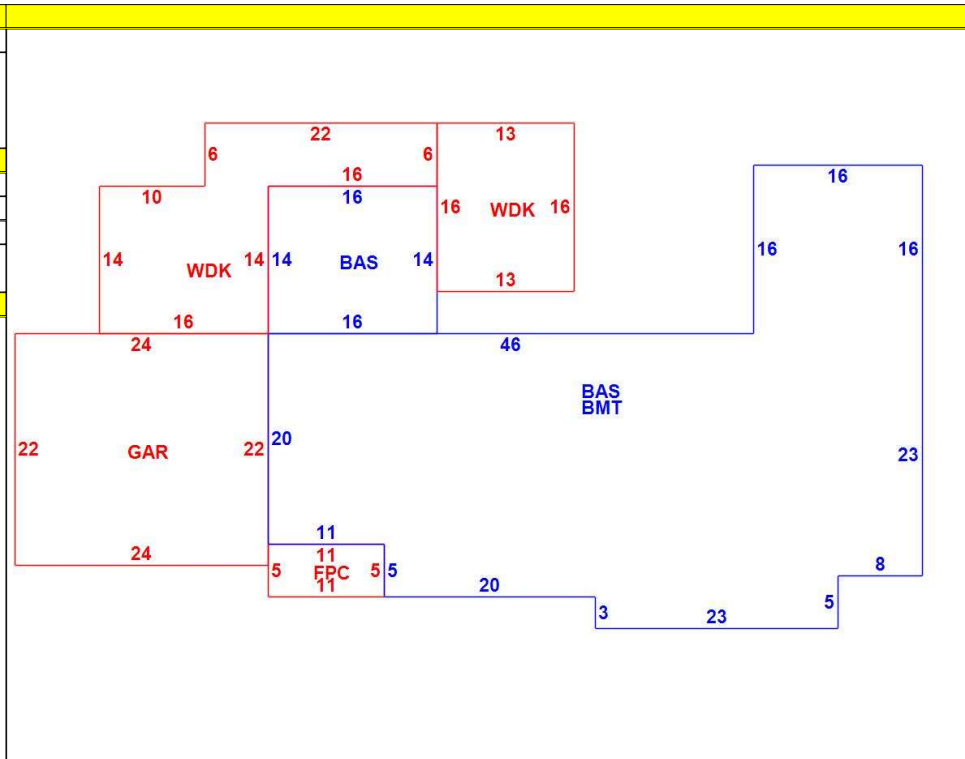

OB - OUTBUILDING & YARD ITEMS(L) / XF - BUILDING EXTRA FEATURES(B)

Code	Description	L/B	Units	Unit Price	Yr Blt	Cond. Cd	% Gd	Grade	Grade Adj.	Appr. Value
FPL1	Fireplace 1 sto	B	1	5000.00	2000		84		0.00	4,200
WDC	Wood Decking	L	356	20.00	2004		70		0.00	4,900
FOPC	Open Prch-roo	B	55	55.00	2000		84		0.00	2,600
GAR	Attached Gara	B	528	40.00	2000		84		0.00	16,200
BMT	Basement-Unfi	B	1,804	26.01	2000		84		0.00	34,400
WDC	Wood Deck w/	L	208	18.00	2004		70		0.00	3,000
GEN	Emergency Ge	L	1	5550.00	2012		86		0.00	4,800
FPLG	Gas Fireplace-	B	1	2500.00	2000		84		0.00	2,100
SHED	Shed	L	120	18.00	2004		70		0.00	1,500

BUILDING SUB-AREA SUMMARY SECTION

Code	Description	Living Area	Floor Area	Eff Area	Unit Cost	Undeprec Value
BAS	First Floor	2,028	2,028	2,028	298.78	605,930
BMT	Basement Area	0	1,804	0	0.00	0
FPC	Open Porch Conc. Floor	0	55	0	0.00	0
GAR	Attached Garage	0	528	0	0.00	0
WDK	Wood Deck	0	564	0	0.00	0
Ttl Gross Liv / Lease Area		2,028	4,979	2,028		605,930

