

CURRENT OWNER		TOPO	UTILITIES	STRT / ROAD	LOCATION	CURRENT ASSESSMENT				801 FY2024 BARNSTABLE, MA VISION
OUELLETTE, JEANNETTE M 33 GERALDINE RD COTUIT MA 02635		1 Level	2 Public Water			Description RESIDNTL RES LAND	Code 1010 1010	Assessed 452,800 155,900	Assessed 452,800 155,900	
			4 Gas	1 Paved						
			6 Septic							
SUPPLEMENTAL DATA						Total 608,700 608,700				
Alt Prcl ID		Split Zonin		Plan Ref. 178/151						
BID Parcel		ResExpt Q		Land Ct#						
#DL 1		INFO: LOT 2		#SR						
#DL 2				Life Estate						
GIS ID		F_948463_2697508		PP STATU						
				Assoc Pid#						

RECORD OF OWNERSHIP		BK-VOL/PAGE	SALE DATE	Q/U	V/I	SALE PRIC	VC	PREVIOUS ASSESSMENTS (HISTORY)									
OUELLETTE, JEANNETTE M		11724	0065	09-25-1998	Q	I	153,000	00	Year	Code	Assessed	Year	Code	Assessed			
LEFAVOR, WALTER R & VIRGINIA A		2537	0093	06-29-1977	U		0		2023	1010	401,100	2022	1010	340,300			
										1010	141,700		1010	105,000			
												2021	1010	289,000			
													1010	105,000			
													1010	4,300			
									Total		542,800	Total		445,300	Total		398,300

EXEMPTIONS				OTHER ASSESSMENTS				This signature acknowledges a visit by a Data Collector or Assessor										
Year	Code	Description	Amount	Code	Description	Number	Amount	Comm Int										
2024	N5C	NO RESIDENTIAL EXEMPTION	0.00															
Total			0.00															

ASSESSING NEIGHBORHOOD				APPRAISED VALUE SUMMARY			
Nbhd	Nbhd Name	B	Tracing	Batch			
0105			COTUIT				

NOTES										APPRAISED VALUE SUMMARY				
										Appraised Bldg. Value (Card)	408,800			
										Appraised Xf (B) Value (Bldg)	39,700			
										Appraised Ob (B) Value (Bldg)	4,300			
										Appraised Land Value (Bldg)	155,900			
										Special Land Value	0			
										Total Appraised Parcel Value	608,700			
										Valuation Method	C			
										Total Appraised Parcel Value	608,700			

BUILDING PERMIT RECORD									VISIT / CHANGE HISTORY					
Permit Id	Issue Date	Type	Description	Amount	Insp Date	% Comp	Date Comp	Comments	Date	Id	Type	Is	Cd	Purpost/Result
17-3545	10-18-2017	804	Addn Alt-Res	12,000	05-16-2018	100	06-30-2018	Install new ballusters to existin	06-11-2020	WD			FR	Field Review
B30720	05-01-1987	AD	Addition	14,000	01-15-1988	100	06-30-1988	CO ADD'N	06-26-2018	SR	01		02	Bldg Permit Completed
									01-08-2014	JR	03		16	In Office Review
									01-16-2013	RB	03		03	Cycl Insp Comp
									07-05-2005	PT	02		01	Meas/Est
									03-23-1999	FS	01		00	Meas/Listed-Interior Acces

LAND LINE VALUATION SECTION																	
B	Use Code	Description	Zone	LA	Land Units	Unit Price	Size Adj	AC Disc	Site Index	Cond.	Nbhd.	Nbhd. Adj	Notes	Location Adjustmen	Adj Unit P	Land Value	
1	1010	Single Fam M-0	RF	2	0.460	AC	176,344.00	1.92125	1.0000	5	1.00	0105	1.000		1.0000	338,809.7	155,900
Total Card Land Units					0.46	AC	Parcel Total Land Area					0.46	Total Land Value			155,900	

CONSTRUCTION DETAIL			CONSTRUCTION DETAIL (CONTINUED)		
Element	Cd	Description	Element	Cd	Description
Style	04	Cape Cod			
Model	01	Residential			
Grade:	C	Average			
Stories	1.5	1 1/2 Stories			
Exterior Wall 1	25	Vinyl Siding			
Exterior Wall 2					
RooF Structure	03	Gable/Hip			
RooF Cover	03	Asph/F Gls/Cmp			
Interior Wall 1	05	Drywall			
Interior Wall 2					
Interior Floor 1	14	Carpet			
Interior Floor 2					
Heat Fuel	03	Gas			
Heat Type	04	Hot Air			
AC Type	01	None			
Bedrooms	05	5 Bedrooms			
Full Baths	3				
Half Baths	0				
Extra Fixtures					
Total Rooms	10	10 Rooms			
Bath Style					
Kitchen Style					
Occupancy					
UsrflD 105					
Accessory Apt	Y	Apt here			
Foundation Alt	01	Poured Conc.			
Rms Prts					
Bath Split	30	3 Full-0 Half			

CONDO DATA				
Parcel Id		C	Owne	0.0
Adjust Type	Code	Description	Factor%	
Condo Flr				
Condo Unit				

COST / MARKET VALUATION	
Building Value New	530,957
Year Built	1968
Effective Year Built	1990
Depreciation Code	A
Remodel Rating	
Year Remodeled	
Depreciation %	23
Functional Obsol	0
External Obsol	0
Trend Factor	1
Condition	
Condition %	
Percent Good	77
RCNLD	408,800
Dep % Ovr	
Dep Ovr Comment	
Misc Imp Ovr	
Misc Imp Ovr Comment	
Cost to Cure Ovr	
Cost to Cure Ovr Comment	

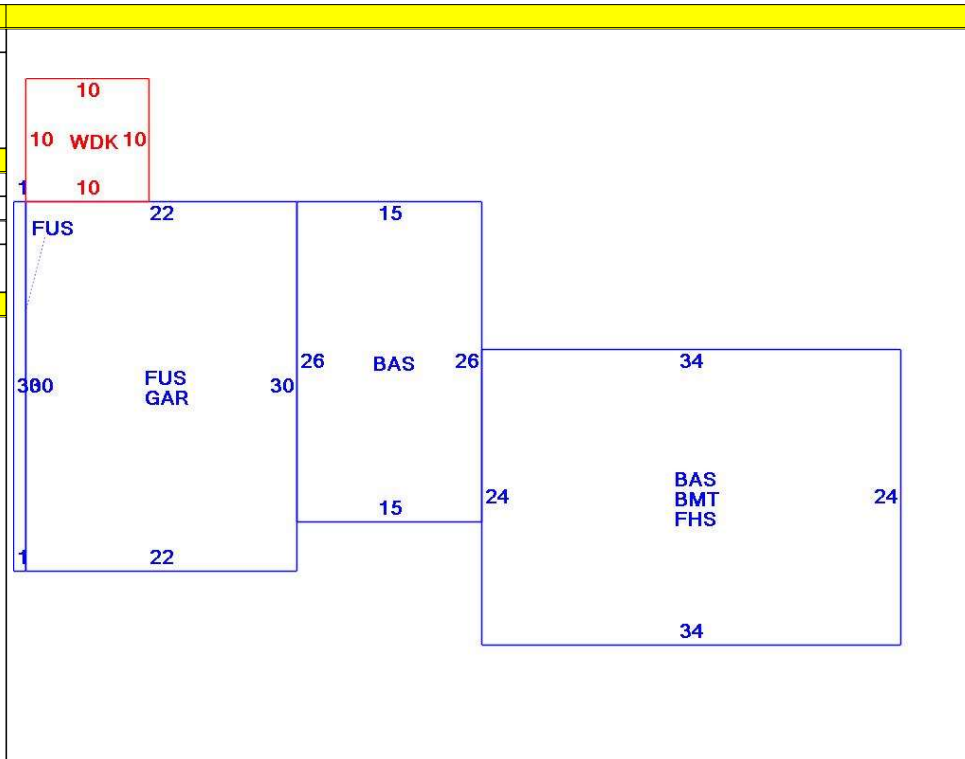

OB - OUTBUILDING & YARD ITEMS(L) / XF - BUILDING EXTRA FEATURES(B)										
Code	Description	L/B	Units	Unit Price	Yr Blt	Cond. Cd	% Gd	Grade	Grade Adj.	Appr. Value
FPL2	Fireplace 1.5 s	B	1	6000.00	1992		77		0.00	4,600
WDC	Wood Decking	L	100	20.00	2017		96		0.00	3,300
GAR	Attached Gara	B	660	40.00	1992		77		0.00	17,400
BMT	Basement-Unfi	B	816	26.01	1992		77		0.00	17,700
SHED	Shed	L	96	18.00	1999		60		0.00	1,000

BUILDING SUB-AREA SUMMARY SECTION						
Code	Description	Living Area	Floor Area	Eff Area	Unit Cost	Undeprec Value
BAS	First Floor	1,206	1,206	1,206	230.45	277,923
BMT	Basement Area	0	816	0	0.00	0
FHS	Half Story	408	816	408	115.23	94,024
FUS	Upper Story	690	690	690	230.45	159,011
GAR	Attached Garage	0	660	0	0.00	0
WDK	Wood Deck	0	100	0	0.00	0
Ttl Gross Liv / Lease Area		2,304	4,288	2,304		530,958

