

CONSTRUCTION DETAIL			CONSTRUCTION DETAIL (CONTINUED)		
Element	Cd	Description	Element	Cd	Description
Style	04	Cape Cod			
Model	01	Residential			
Grade:	C+	Average Plus			
Stories	2	2 Stories			
Exterior Wall 1	14	Wood Shingle			
Exterior Wall 2	11	Clapboard			
Roof Structure	11	Bowstring Trus			
Roof Cover	03	Asph/F Gls/Cmp			
Interior Wall 1	05	Drywall			
Interior Wall 2					
Interior Floor 1	14	Carpet			
Interior Floor 2	12	Hardwood			
Heat Fuel	03	Gas			
Heat Type	05	Hot Water			
AC Type	01	None			
Bedrooms	04	4 Bedrooms			
Full Baths	3				
Half Baths	0				
Extra Fixtures					
Total Rooms	8	8 Rooms			
Bath Style					
Kitchen Style					
Occupancy					
Usrflid 105					
Accessory Apt					
Foundation Alt	01	Poured Conc.			
Rms Prts					
Bath Split	30	3 Full-0 Half			
			CONDO DATA		
			Parcel Id	C	Ownr 0.0
				B	S
			Adjust Type	Code	Description
			Condo Flr		
			Condo Unit		
			COST / MARKET VALUATION		
			Building Value New		651,990
			Year Built		1978
			Effective Year Built		1995
			Depreciation Code		A
			Remodel Rating		
			Year Remodeled		
			Depreciation %		19
			Functional Obsol		0
			External Obsol		0
			Trend Factor		1
			Condition		
			Condition %		
			Percent Good		81
			RCNLD		528,100
			Dep % Ovr		
			Dep Ovr Comment		
			Misc Imp Ovr		
			Misc Imp Ovr Comment		
			Cost to Cure Ovr		
			Cost to Cure Ovr Comment		

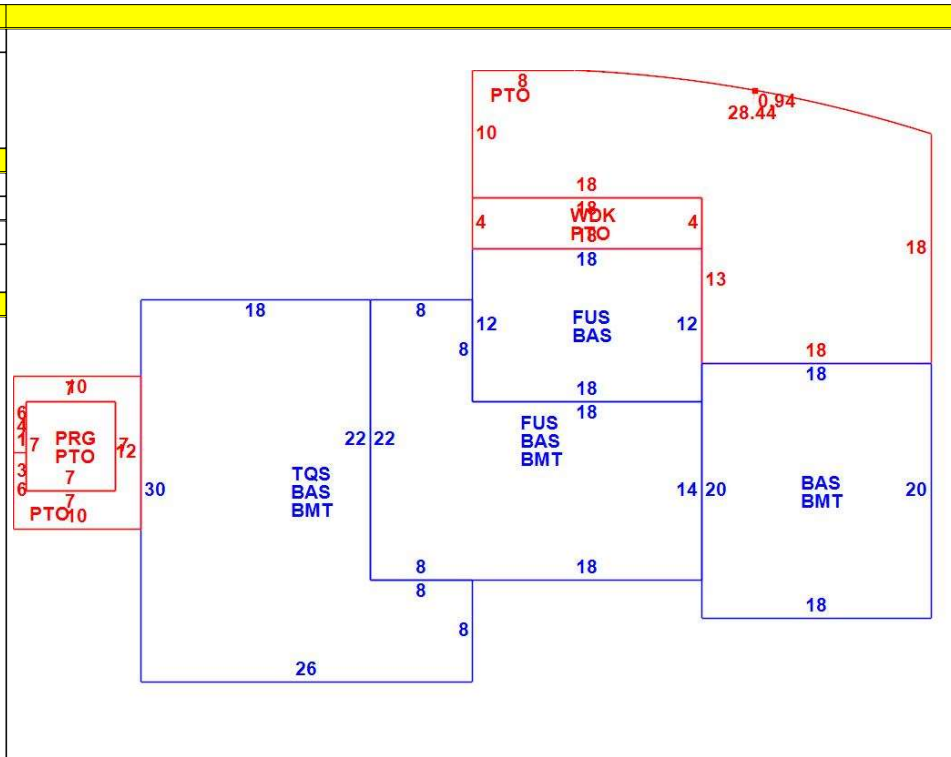

OB - OUTBUILDING & YARD ITEMS(L) / XF - BUILDING EXTRA FEATURES(B)										
Code	Description	L/B	Units	Unit Price	Yr Blt	Cond. Cd	% Gd	Grade	Grade Adj.	Appr. Value
FPL2	Fireplace 1.5 s	B	1	6000.00	1997		81		0.00	4,900
FPO	Ext FP Openin	B	1	2000.00	1997		81		0.00	1,600
WDC	Wood Decking	L	72	20.00	1997		56		0.00	1,900
PAT2	Patio-Good	L	734	9.94	1997		78		0.00	5,300
BMT	Basement-Unfi	B	1,392	26.01	1997		81		0.00	27,200
GEN	Emergency Ge	L	1	5550.00	2012		86		0.00	4,800
SHED	Shed	L	120	18.00	1998		58		0.00	1,300
SOL1	Solar PV Pane	B	18	860.00	1997		0		0.00	0
PRG1	Pergola-Avg	L	49	18.00	2020		100	C	1.00	900

BUILDING SUB-AREA SUMMARY SECTION						
Code	Description	Living Area	Floor Area	Eff Area	Unit Cost	Undeprec Value
BAS	First Floor	1,608	1,608	1,608	246.50	396,370
BMT	Basement Area	0	1,392	0	0.00	0
FUS	Upper Story	644	644	644	246.50	158,745
PRG	Pergola	0	49	0	0.00	0
PTO	Patio	0	734	0	0.00	0
TQS	Three Quarter Story	393	604	393	160.39	96,874
WDK	Wood Deck	0	72	0	0.00	0
Ttl Gross Liv / Lease Area		2,645	5,103	2,645		651,989

