

| CURRENT OWNER | | TOPO | UTILITIES | STRT / ROAD | LOCATION | CURRENT ASSESSMENT | | | | 801 FY2024 BARNSTABLE, MA VISION | |
|--|--|-----------|----------------|--|----------|--------------------|------|----------|----------|--|---------|
| MADDOCKS, KATHLEEN M 212 SALT ROCK RD BARNSTABLE MA 02630 | | 4 Rolling | 6 Septic | 1 Paved | | Description | Code | Assessed | Assessed | | |
| | | | 4 Gas | | | RESIDNTL | 1010 | 446,100 | 446,100 | | |
| | | | 2 Public Water | | | RES LAND | 1010 | 199,200 | 199,200 | | |
| SUPPLEMENTAL DATA | | | | | | Total | | | | 645,300 | 645,300 |
| Alt Prcl ID Split Zonin BID Parcel ResExpt Q YES: #DL 1 LOT 14 #DL 2 GIS ID F_986178_2715475 | | | | Plan Ref. 222/85 Land Ct# #SR Life Estate PP STATU Assoc Pid# | | | | | | | |

| RECORD OF OWNERSHIP | | BK-VOL/PAGE | SALE DATE | Q/U | V/I | SALE PRIC | VC | PREVIOUS ASSESSMENTS (HISTORY) | | | | | | | | |
|---|--|-------------|------------|-----|-----|-----------|----|--------------------------------|------|----------|-------|------|----------|-------|------|----------|
| MADDOCKS, KATHLEEN M | | 17062 0137 | 06-10-2003 | U | I | 1 | 1 | Year | Code | Assessed | Year | Code | Assessed | Year | Code | Assessed |
| FULGINITI, WILLIAM R JR & MOYLAN, THOMAS & PATRICIA | | 6639 0245 | 02-24-1989 | Q | I | 170,000 | U | 2023 | 1010 | 394,600 | 2022 | 1010 | 334,100 | 2021 | 1010 | 280,600 |
| HORST, DAVID J & CAROL W | | 5189 0013 | 07-14-1986 | Q | I | 159,900 | U | | 1010 | 196,900 | | 1010 | 140,000 | | 1010 | 140,000 |
| | | 2162 0341 | 03-20-1975 | U | | 0 | | Total | | 591,500 | Total | | 474,100 | Total | | 423,800 |

| EXEMPTIONS | | | | OTHER ASSESSMENTS | | | | This signature acknowledges a visit by a Data Collector or Assessor | | | | | | | | |
|------------|------|-----------------------|--------|-------------------|-------------|--------|--------|---|--|--|--|--|--|--|--|--|
| Year | Code | Description | Amount | Code | Description | Number | Amount | Comm Int | | | | | | | | |
| 2010 | 5C | RESIDENTIAL EXEMPTION | 0.00 | | | | | | | | | | | | | |
| Total | | | 0.00 | | | | | | | | | | | | | |

| ASSESSING NEIGHBORHOOD | | | | APPRAISED VALUE SUMMARY | | | |
|------------------------|-----------|---|---------|-------------------------|-------------------------------|---------|--|
| Nbhd | Nbhd Name | B | Tracing | Batch | | | |
| 0106 | | | | BARNS | Appraised Bldg. Value (Card) | 405,200 | |
| | | | | | Appraised Xf (B) Value (Bldg) | 37,400 | |
| | | | | | Appraised Ob (B) Value (Bldg) | 3,500 | |
| | | | | | Appraised Land Value (Bldg) | 199,200 | |
| | | | | | Special Land Value | 0 | |
| | | | | | Total Appraised Parcel Value | 645,300 | |
| | | | | | Valuation Method | C | |
| | | | | | Total Appraised Parcel Value | 645,300 | |

| NOTES | | | | | | | | | | VISIT / CHANGE HISTORY | | | | | |
|-------|--|--|--|--|--|--|--|--|--|------------------------|----|------|----|----|----------------------------|
| | | | | | | | | | | Date | Id | Type | Is | Cd | Purpost/Result |
| | | | | | | | | | | 08-17-2023 | SR | 02 | | 03 | Cycl Insp Comp |
| | | | | | | | | | | 05-06-2020 | DM | | | FR | Field Review |
| | | | | | | | | | | 10-21-2015 | SR | 02 | | 03 | Cycl Insp Comp |
| | | | | | | | | | | 07-10-2014 | JR | 03 | | 16 | In Office Review |
| | | | | | | | | | | 01-14-2005 | JS | 02 | | 01 | Meas/Est |
| | | | | | | | | | | 10-05-2000 | MF | 01 | | 00 | Meas/Listed-Interior Acces |
| | | | | | | | | | | 06-02-1998 | LK | | | | |

| BUILDING PERMIT RECORD | | | | | | | | | | LAND LINE VALUATION SECTION | | | | | |
|------------------------|------------|------|----------------|--------|------------|--------|------------|----------------------------------|--|-----------------------------|----|------|----|----|----------------|
| Permit Id | Issue Date | Type | Description | Amount | Insp Date | % Comp | Date Comp | Comments | | Date | Id | Type | Is | Cd | Purpost/Result |
| 16-3663 | 12-14-2016 | 835 | Sid/Wind/Roof/ | 4,900 | 06-30-2017 | 100 | 06-30-2017 | re-roof stripping old - yarmouth | | 08-17-2023 | SR | 02 | | 03 | Cycl Insp Comp |
| 13147 | 02-07-1996 | AD | Addition | 14,000 | 08-28-1997 | 100 | 01-01-1997 | Fam room | | 05-06-2020 | DM | | | FR | Field Review |

| B | Use Code | Description | Zone | LA | Land Units | Unit Price | Size Adj | AC Disc | Site Index | Cond. | Nbhd. | Nbhd. Adj | Notes | Location Adjustmen | Adj Unit P | Land Value |
|-----------------------|----------|----------------|------|----|------------|------------|------------------------|---------|------------|-------|-------|-----------|------------------|--------------------|------------|------------|
| 1 | 1010 | Single Fam M-0 | RF-1 | 1 | 0.810 AC | 176,344.00 | 1.21279 | 1.0000 | 5 | 1.00 | 0106 | 1.150 | | 1.0000 | 245,946.9 | 199,200 |
| Total Card Land Units | | | | | 0.81 | AC | Parcel Total Land Area | | | | | 0.81 | Total Land Value | | | 199,200 |

| CONSTRUCTION DETAIL | | | CONSTRUCTION DETAIL (CONTINUED) | | |
|---------------------|------|----------------|---------------------------------|----|-------------|
| Element | Cd | Description | Element | Cd | Description |
| Style | 04 | Cape Cod | | | |
| Model | 01 | Residential | | | |
| Grade: | C+ | Average Plus | | | |
| Stories | 1.75 | 1 3/4 Stories | | | |
| Exterior Wall 1 | 14 | Wood Shingle | | | |
| Exterior Wall 2 | 11 | Clapboard | | | |
| Roof Structure | 03 | Gable/Hip | | | |
| Roof Cover | 03 | Asph/F Gls/Cmp | | | |
| Interior Wall 1 | 05 | Drywall | | | |
| Interior Wall 2 | | | | | |
| Interior Floor 1 | 14 | Carpet | | | |
| Interior Floor 2 | 12 | Hardwood | | | |
| Heat Fuel | 03 | Gas | | | |
| Heat Type | 05 | Hot Water | | | |
| AC Type | 01 | None | | | |
| Bedrooms | 04 | 4 Bedrooms | | | |
| Full Baths | 2 | | | | |
| Half Baths | 0 | | | | |
| Extra Fixtures | | | | | |
| Total Rooms | 7 | 7 Rooms | | | |
| Bath Style | | | | | |
| Kitchen Style | | | | | |
| Occupancy | | | | | |
| Usrflid 105 | | | | | |
| Accessory Apt | | | | | |
| Foundation Alt | 01 | Poured Conc. | | | |
| Rms Prts | | | | | |
| Bath Split | 20 | 2 Full-0 Half | | | |

| CONDO DATA | | | | |
|-------------|------|-------------|---------|-----|
| Parcel Id | | C | Owne | 0.0 |
| Adjust Type | Code | Description | Factor% | |
| Condo Flr | | | | |
| Condo Unit | | | | |

| COST / MARKET VALUATION | |
|--------------------------|---------|
| Building Value New | 506,532 |
| Year Built | 1974 |
| Effective Year Built | 1993 |
| Depreciation Code | A |
| Remodel Rating | |
| Year Remodeled | |
| Depreciation % | 20 |
| Functional Obsol | 0 |
| External Obsol | 0 |
| Trend Factor | 1 |
| Condition | |
| Condition % | |
| Percent Good | 80 |
| RCNLD | 405,200 |
| Dep % Ovr | |
| Dep Ovr Comment | |
| Misc Imp Ovr | |
| Misc Imp Ovr Comment | |
| Cost to Cure Ovr | |
| Cost to Cure Ovr Comment | |

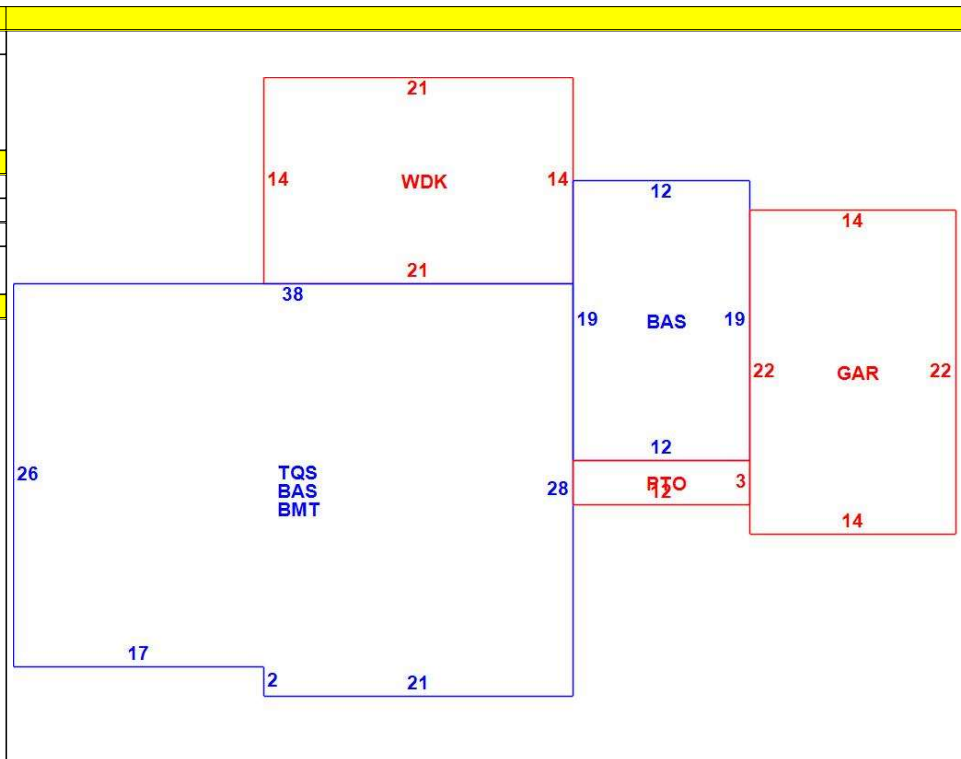

| OB - OUTBUILDING & YARD ITEMS(L) / XF - BUILDING EXTRA FEATURES(B) | | | | | | | | | | |
|--|-----------------|-----|-------|------------|--------|----------|------|-------|------------|-------------|
| Code | Description | L/B | Units | Unit Price | Yr Blt | Cond. Cd | % Gd | Grade | Grade Adj. | Appr. Value |
| FPL2 | Fireplace 1.5 s | B | 1 | 6000.00 | 1995 | | 80 | | 0.00 | 4,800 |
| WDC | Wood Decking | L | 294 | 20.00 | 1996 | | 54 | | 0.00 | 3,200 |
| GAR | Attached Gara | B | 308 | 40.00 | 1995 | | 80 | | 0.00 | 10,900 |
| BMT | Basement-Unfi | B | 1,030 | 26.01 | 1995 | | 80 | | 0.00 | 21,700 |
| PAT1 | Patio- Average | L | 36 | 5.89 | 2020 | | 100 | | 0.00 | 300 |

| BUILDING SUB-AREA SUMMARY SECTION | | | | | | |
|-----------------------------------|---------------------|-------------|------------|----------|-----------|----------------|
| Code | Description | Living Area | Floor Area | Eff Area | Unit Cost | Undeprec Value |
| BAS | First Floor | 1,258 | 1,258 | 1,258 | 262.72 | 330,507 |
| BMT | Basement Area | 0 | 1,030 | 0 | 0.00 | 0 |
| GAR | Attached Garage | 0 | 308 | 0 | 0.00 | 0 |
| PTO | Patio | 0 | 36 | 0 | 0.00 | 0 |
| TQS | Three Quarter Story | 670 | 1,030 | 670 | 170.90 | 176,025 |
| WDK | Wood Deck | 0 | 294 | 0 | 0.00 | 0 |
| Ttl Gross Liv / Lease Area | | 1,928 | 3,956 | 1,928 | | 506,532 |

