

| CURRENT OWNER | | TOPO | UTILITIES | STRT / ROAD | LOCATION | CURRENT ASSESSMENT | | | |
|--|--|----------------|----------------|------------------|----------|--------------------|------|----------|----------|
| MOORE, CHRISTOPHER H & DIANNA 94 MARBLE RD BARNSTABLE MA 02630 | | 1 Level | 6 Septic | 1 Paved | | Description | Code | Assessed | Assessed |
| | | | 4 Gas | | | RESIDNTL | 1010 | 457,900 | 457,900 |
| | | | 2 Public Water | | | RES LAND | 1010 | 242,800 | 242,800 |
| SUPPLEMENTAL DATA | | | | | | Total | | | |
| Alt Prcl ID | | Split Zonin | | Plan Ref. 222/85 | | | | | |
| BID Parcel | | ResExpt Q YES: | | Land Ct# | | | | | |
| #DL 1 LOT 34 | | #DL 2 | | Life Estate | | | | | |
| GIS ID F_986655_2715514 | | Assoc Pid# | | | | | | | |

801
 FY2024
 BARNSTABLE, MA

VISION

| RECORD OF OWNERSHIP | | BK-VOL/PAGE | SALE DATE | Q/U | V/I | SALE PRIC | VC | PREVIOUS ASSESSMENTS (HISTORY) | | | | | | |
|-----------------------------------|--|-------------|-----------|------------|-----|-----------|---------|--------------------------------|-------|------|----------|-------|------|----------|
| MOORE, CHRISTOPHER H & DIANNA W | | 12948 | 0062 | 04-14-2000 | Q | I | 200,000 | 00 | Year | Code | Assessed | Year | Code | Assessed |
| BUFFUM, RICHARD S & BARBARA E | | 4970 | 0324 | 03-20-1986 | Q | I | 147,500 | U | 2023 | 1010 | 406,400 | 2022 | 1010 | 341,600 |
| LEBLANC, M ELIZABETH & MOONEY, LA | | 3004 | 0089 | 10-26-1979 | U | | 0 | | | 1010 | 220,700 | | 1010 | 151,800 |
| | | | | | | | | | Total | | 627,100 | Total | | 493,400 |
| | | | | | | | | | Total | | | Total | | 449,200 |

| EXEMPTIONS | | | | OTHER ASSESSMENTS | | | |
|------------|------|-----------------------|--------|-------------------|-------------|--------|--------|
| Year | Code | Description | Amount | Code | Description | Number | Amount |
| 2023 | 5C | RESIDENTIAL EXEMPTION | 0.00 | | | | |
| 2024 | 37 | BLIND | | | | | |
| Total | | | 0.00 | | | | |

This signature acknowledges a visit by a Data Collector or Assessor

| ASSESSING NEIGHBORHOOD | | | | APPRAISED VALUE SUMMARY | | | |
|------------------------|-----------|---|---------|--------------------------------------|--|--|--|
| Nbhd | Nbhd Name | B | Tracing | Batch | | | |
| 0107 | | | | BARNS | | | |
| NOTES | | | | Appraised Bldg. Value (Card) 407,100 | | | |
| | | | | Appraised Xf (B) Value (Bldg) 47,000 | | | |
| | | | | Appraised Ob (B) Value (Bldg) 3,800 | | | |
| | | | | Appraised Land Value (Bldg) 242,800 | | | |
| | | | | Special Land Value 0 | | | |
| | | | | Total Appraised Parcel Value 700,700 | | | |
| | | | | Valuation Method C | | | |
| | | | | Total Appraised Parcel Value 700,700 | | | |

| BUILDING PERMIT RECORD | | | | | | | | VISIT / CHANGE HISTORY | | | | | | |
|------------------------|------------|------|-------------|--------|------------|--------|------------|------------------------|------------|----|------|----|----|------------------|
| Permit Id | Issue Date | Type | Description | Amount | Insp Date | % Comp | Date Comp | Comments | Date | Id | Type | Is | Cd | Purpost/Result |
| 69222 | 06-03-2003 | AD | Addition | 63,000 | 09-10-2003 | 100 | 01-01-2004 | | 08-24-2023 | SR | 01 | | 03 | Cycl Insp Comp |
| 68932 | 05-22-2003 | NS | New Siding | 11,000 | 05-19-2004 | 100 | 01-01-2004 | | 08-22-2023 | EG | 03 | | 16 | In Office Review |
| | | | | | | | | | 10-21-2022 | EG | 03 | | 16 | In Office Review |
| | | | | | | | | | 10-21-2022 | EG | 03 | | 16 | In Office Review |
| | | | | | | | | | 09-16-2021 | JD | 03 | | 16 | In Office Review |
| | | | | | | | | | 10-23-2020 | JD | 03 | | 16 | In Office Review |
| | | | | | | | | | 05-06-2020 | DM | | | FR | Field Review |

| LAND LINE VALUATION SECTION | | | | | | | | | | | | | | | | | |
|-----------------------------|----------|----------------|------|----|------------|------------|------------------------|---------|------------|-------|-------|-----------|------------------|--------------------|------------|------------|---------|
| B | Use Code | Description | Zone | LA | Land Units | Unit Price | Size Adj | AC Disc | Site Index | Cond. | Nbhd. | Nbhd. Adj | Notes | Location Adjustmen | Adj Unit P | Land Value | |
| 1 | 1010 | Single Fam M-0 | RF-1 | 1 | 0.820 | AC | 176,344.00 | 1.19913 | 1.0000 | 5 | 1.00 | 0107 | 1.400 | | 1.0000 | 296,046.3 | 242,800 |
| Total Card Land Units | | | | | 0.82 | AC | Parcel Total Land Area | | | | | 0.82 | Total Land Value | | | 242,800 | |

| CONSTRUCTION DETAIL | | | CONSTRUCTION DETAIL (CONTINUED) | | |
|---------------------|------|----------------|--------------------------------------|----|-------------|
| Element | Cd | Description | Element | Cd | Description |
| Style | 04 | Cape Cod | | | |
| Model | 01 | Residential | | | |
| Grade: | C | Average | | | |
| Stories | 1.75 | 1 3/4 Stories | | | |
| Exterior Wall 1 | 14 | Wood Shingle | | | |
| Exterior Wall 2 | 25 | Vinyl Siding | | | |
| Roof Structure | 03 | Gable/Hip | | | |
| Roof Cover | 03 | Asph/F Gls/Cmp | | | |
| Interior Wall 1 | 05 | Drywall | | | |
| Interior Wall 2 | | | | | |
| Interior Floor 1 | 14 | Carpet | | | |
| Interior Floor 2 | 12 | Hardwood | | | |
| Heat Fuel | 03 | Gas | | | |
| Heat Type | 05 | Hot Water | | | |
| AC Type | 03 | Central | | | |
| Bedrooms | 03 | 3 Bedrooms | | | |
| Full Baths | 2 | | | | |
| Half Baths | 1 | | | | |
| Extra Fixtures | | | | | |
| Total Rooms | 7 | 7 Rooms | | | |
| Bath Style | | | | | |
| Kitchen Style | | | | | |
| Occupancy | | | | | |
| Usrflid 105 | | | | | |
| Accessory Apt | | | | | |
| Foundation Alt | 01 | Poured Conc. | | | |
| Rms Prts | | | | | |
| Bath Split | 21 | 2 Full-1 Half | | | |
| | | | CONDO DATA | | |
| | | | Parcel Id | C | Owne 0.0 |
| | | | Adjust Type Code Description Factor% | | |
| | | | Condo Flr | | |
| | | | Condo Unit | | |
| | | | COST / MARKET VALUATION | | |
| | | | Building Value New | | 484,668 |
| | | | Year Built | | 1974 |
| | | | Effective Year Built | | 1998 |
| | | | Depreciation Code | | G |
| | | | Remodel Rating | | |
| | | | Year Remodeled | | |
| | | | Depreciation % | | 16 |
| | | | Functional Obsol | | 0 |
| | | | External Obsol | | 0 |
| | | | Trend Factor | | 1 |
| | | | Condition | | |
| | | | Condition % | | |
| | | | Percent Good | | 84 |
| | | | RCNLD | | 407,100 |
| | | | Dep % Ovr | | |
| | | | Dep Ovr Comment | | |
| | | | Misc Imp Ovr | | |
| | | | Misc Imp Ovr Comment | | |
| | | | Cost to Cure Ovr | | |
| | | | Cost to Cure Ovr Comment | | |

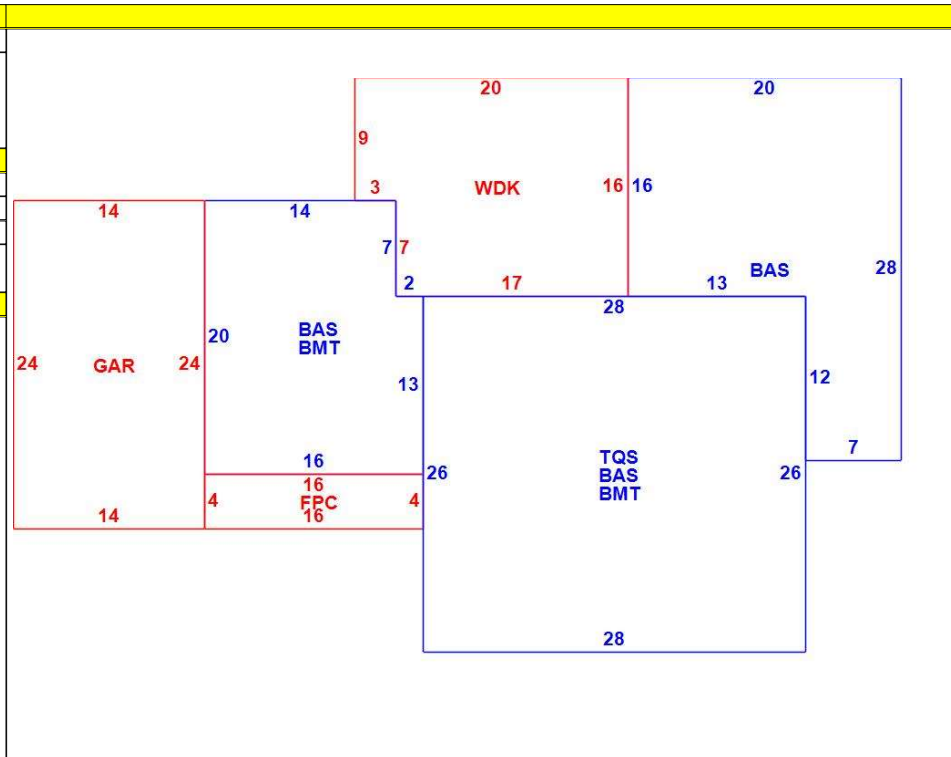

| OB - OUTBUILDING & YARD ITEMS(L) / XF - BUILDING EXTRA FEATURES(B) | | | | | | | | | | |
|--|-----------------|-----|-------|------------|--------|----------|------|-------|------------|-------------|
| Code | Description | L/B | Units | Unit Price | Yr Blt | Cond. Cd | % Gd | Grade | Grade Adj. | Appr. Value |
| FPL2 | Fireplace 1.5 s | B | 1 | 6000.00 | 2000 | | 84 | | 0.00 | 5,000 |
| WDC | Wood Decking | L | 299 | 20.00 | 2001 | | 64 | | 0.00 | 3,800 |
| FOPC | Open Prch-roo | B | 64 | 55.00 | 2000 | | 84 | | 0.00 | 2,900 |
| GAR | Attached Gara | B | 336 | 40.00 | 2000 | | 84 | | 0.00 | 12,100 |
| BMT | Basement-Unfi | B | 1,034 | 26.01 | 2000 | | 84 | | 0.00 | 22,800 |
| FPLG | Gas Fireplace- | B | 1 | 2500.00 | 2000 | | 84 | | 0.00 | 2,100 |
| FPLG | Gas Fireplace- | B | 1 | 2500.00 | 2000 | | 84 | | 0.00 | 2,100 |

| BUILDING SUB-AREA SUMMARY SECTION | | | | | | |
|-----------------------------------|------------------------|-------------|------------|----------|-----------|----------------|
| Code | Description | Living Area | Floor Area | Eff Area | Unit Cost | Undeprec Value |
| BAS | First Floor | 1,438 | 1,438 | 1,438 | 253.62 | 364,706 |
| BMT | Basement Area | 0 | 1,034 | 0 | 0.00 | 0 |
| FPC | Open Porch Conc. Floor | 0 | 64 | 0 | 0.00 | 0 |
| GAR | Attached Garage | 0 | 336 | 0 | 0.00 | 0 |
| TQS | Three Quarter Story | 473 | 728 | 473 | 164.78 | 119,962 |
| WDK | Wood Deck | 0 | 299 | 0 | 0.00 | 0 |
| Ttl Gross Liv / Lease Area | | 1,911 | 3,899 | 1,911 | | 484,668 |

