

CONSTRUCTION DETAIL			CONSTRUCTION DETAIL (CONTINUED)		
Element	Cd	Description	Element	Cd	Description
Style	04	Cape Cod			
Model	01	Residential			
Grade:	C	Average			
Stories	1.5	1 1/2 Stories			
Exterior Wall 1	14	Wood Shingle			
Exterior Wall 2					
RooF Structure	03	Gable/Hip			
RooF Cover	03	Asph/F Gls/Cmp			
Interior Wall 1	05	Drywall			
Interior Wall 2					
Interior Floor 1	12	Hardwood			
Interior Floor 2					
Heat Fuel	03	Gas			
Heat Type	05	Hot Water			
AC Type	01	None			
Bedrooms	03	3 Bedrooms			
Full Baths	2				
Half Baths	0				
Extra Fixtures					
Total Rooms	7	7 Rooms			
Bath Style					
Kitchen Style					
Occupancy					
UsrflD 105					
Accessory Apt					
Foundation Alt	01	Poured Conc.			
Rms Prts					
Bath Split	20	2 Full-0 Half			

CONDO DATA				
Parcel Id		C	Owne	0.0
Adjust Type	Code	Description	Factor%	
Condo Flr				
Condo Unit				

COST / MARKET VALUATION	
Building Value New	468,089
Year Built	1976
Effective Year Built	1994
Depreciation Code	A
Remodel Rating	
Year Remodeled	
Depreciation %	19
Functional Obsol	0
External Obsol	0
Trend Factor	1
Condition	
Condition %	
Percent Good	81
RCNLD	379,200
Dep % Ovr	
Dep Ovr Comment	
Misc Imp Ovr	
Misc Imp Ovr Comment	
Cost to Cure Ovr	
Cost to Cure Ovr Comment	

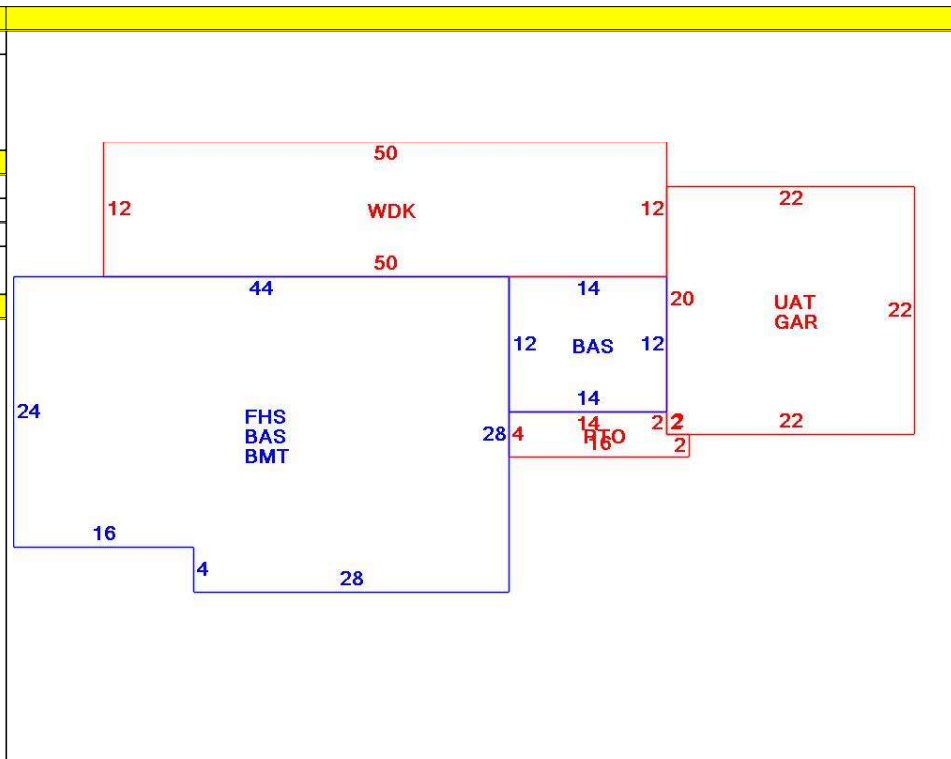

OB - OUTBUILDING & YARD ITEMS(L) / XF - BUILDING EXTRA FEATURES(B)										
Code	Description	L/B	Units	Unit Price	Yr Blt	Cond. Cd	% Gd	Grade	Grade Adj.	Appr. Value
FPL2	Fireplace 1.5 s	B	1	6000.00	1996		81		0.00	4,900
FPO	Ext FP Openin	B	1	2000.00	1996		81		0.00	1,600
BRR	Bsmt Rec Rm-	B	584	8.05	1996		81		0.00	3,800
WDC	Wood Decking	L	600	20.00	1997		56		0.00	6,200
GAR	Attached Gara	B	484	40.00	1996		81		0.00	14,700
BMT	Basement-Unfi	B	1,168	26.01	1996		81		0.00	23,800
PATC	Conc Pavers	L	60	15.46	1998		79		0.00	900

BUILDING SUB-AREA SUMMARY SECTION						
Code	Description	Living Area	Floor Area	Eff Area	Unit Cost	Undeprec Value
BAS	First Floor	1,336	1,336	1,336	237.85	317,768
BMT	Basement Area	0	1,168	0	0.00	0
FHS	Half Story	584	1,168	584	118.93	138,904
GAR	Attached Garage	0	484	0	0.00	0
PTO	Patio	0	60	0	0.00	0
UAT	Attic, Unfinished	0	484	48	23.59	11,417
WDK	Wood Deck	0	600	0	0.00	0
Ttl Gross Liv / Lease Area		1,920	5,300	1,968		468,089

