

CURRENT OWNER		TOPO	UTILITIES	STRT / ROAD	LOCATION	CURRENT ASSESSMENT			
WAGENBLASS, PETER H & CHRISTI PO BOX 556 CUMMAQUID MA 02637		2 Above Street	2 Public Water	3 Unpaved		Description	Code	Assessed	Assessed
			4 Gas			RESIDNTL	1010	313,700	313,700
			6 Septic			RES LAND	1010	540,100	540,100
SUPPLEMENTAL DATA									
Alt Prcl ID Split Zonin BID Parcel ResExpt Q YES: #DL 1 LOT 33A #DL 2 32A GIS ID F_987973_2718820				Plan Ref. 134/55 Land Ct# #SR Life Estate PP STATU Assoc Pid#		Total 853,800 853,800			

801
 FY2024
 BARNSTABLE, MA

VISION

RECORD OF OWNERSHIP		BK-VOL/PAGE	SALE DATE	Q/U	V/I	SALE PRIC	VC	PREVIOUS ASSESSMENTS (HISTORY)					
WAGENBLASS, PETER H & CHRISTINE	32803	0081	04-01-2020	Q	I	498,000	00	Year	Code	Assessed	Year	Code	Assessed
WELCH, LAUREL A TR	32803	0079	04-01-2020	U	I	0	1F	2023	1010	282,000	2022	1010	237,400
WYLAN, BARBARA TR	20540	0290	12-06-2005	U	I	0	1A		1010	380,100		1010	322,600
WYLAN, BARBARA	4565	0309	06-15-1985	Q	I	131,140	U					1010	8,100
AHEARN, FRANCIS W & MARGARET C	3114	0067	06-23-1980	U		0		Total		662,100	Total		560,000
								Total		498,700	Total		498,700

EXEMPTIONS			OTHER ASSESSMENTS					
Year	Code	Description	Amount	Code	Description	Number	Amount	Comm Int
2022	5C	RESIDENTIAL EXEMPTION						
Total			0.00					

This signature acknowledges a visit by a Data Collector or Assessor

ASSESSING NEIGHBORHOOD			
Nbhd	Nbhd Name	B	Tracing
0110			BARNS

APPRAISED VALUE SUMMARY	
Appraised Bldg. Value (Card)	276,900
Appraised Xf (B) Value (Bldg)	28,700
Appraised Ob (B) Value (Bldg)	8,100
Appraised Land Value (Bldg)	540,100
Special Land Value	0
Total Appraised Parcel Value	853,800
Valuation Method	C
Total Appraised Parcel Value	853,800

NOTES							

BUILDING PERMIT RECORD								VISIT / CHANGE HISTORY						
Permit Id	Issue Date	Type	Description	Amount	Insp Date	% Comp	Date Comp	Comments	Date	Id	Type	Is	Cd	Purpost/Result
EXPR-23-2	03-06-2023	835	Sid/Wind/Roof/	789		100		Install R-19 fg to basement sill	06-21-2023	WT	01	1	03	Cycl Insp Comp
201205008	08-20-2012	IN	Insulation	3,600	06-30-2013	100	06-30-2013	INSULATE	10-01-2021	AS	03		16	In Office Review
B29175	04-01-1986	WD	Wood Deck	3,000	01-15-1987	100	06-30-1987	BA DECK	10-22-2020	CK	22		22	Change of Address
B22799	01-01-1981	DW	Dwelling	0	01-15-1982	100	06-30-1982	BA 11/2 S	07-23-2020	CK	03		16	In Office Review
									07-23-2020	CK	22		22	Change of Address
									05-06-2020	DM			FR	Field Review
									10-01-2015	SR	01		03	Cycl Insp Comp

LAND LINE VALUATION SECTION																	
B	Use Code	Description	Zone	LA	Land Units	Unit Price	Size Adj	AC Disc	Site Index	Cond.	Nbhd.	Nbhd. Adj	Notes	Location Adjustmen	Adj Unit P	Land Value	
1	1010	Single Fam M-0	RF-1	1	0.870	AC	176,344.00	1.13555	1.0000	5	1.00	0110	3.100		1.0000	620,766.1	540,100
Total Card Land Units					0.87	AC	Parcel Total Land Area					0.87	Total Land Value			540,100	

CONSTRUCTION DETAIL			CONSTRUCTION DETAIL (CONTINUED)		
Element	Cd	Description	Element	Cd	Description
Style	04	Cape Cod			
Model	01	Residential			
Grade:	C	Average			
Stories	1.4				
Exterior Wall 1	14	Wood Shingle			
Exterior Wall 2					
Roof Structure	03	Gable/Hip			
Roof Cover	03	Asph/F Gls/Cmp			
Interior Wall 1	05	Drywall			
Interior Wall 2					
Interior Floor 1	12	Hardwood			
Interior Floor 2	14	Carpet			
Heat Fuel	02	Oil			
Heat Type	04	Hot Air			
AC Type	01	None			
Bedrooms	03	3 Bedrooms			
Full Baths	2				
Half Baths	0				
Extra Fixtures					
Total Rooms	6	6 Rooms			
Bath Style					
Kitchen Style					
Occupancy					
Usrflid 105					
Accessory Apt					
Foundation Alt	01	Poured Conc.			
Rms Prts					
Bath Split	20	2 Full-0 Half			

CONDO DATA				
Parcel Id		C	Owne	0.0
Adjust Type	Code	Description	Factor%	
Condo Flr				
Condo Unit				

COST / MARKET VALUATION	
Building Value New	337,663
Year Built	1981
Effective Year Built	1996
Depreciation Code	A
Remodel Rating	
Year Remodeled	
Depreciation %	18
Functional Obsol	0
External Obsol	0
Trend Factor	1
Condition	
Condition %	
Percent Good	82
RCNLD	276,900
Dep % Ovr	
Dep Ovr Comment	
Misc Imp Ovr	
Misc Imp Ovr Comment	
Cost to Cure Ovr	
Cost to Cure Ovr Comment	

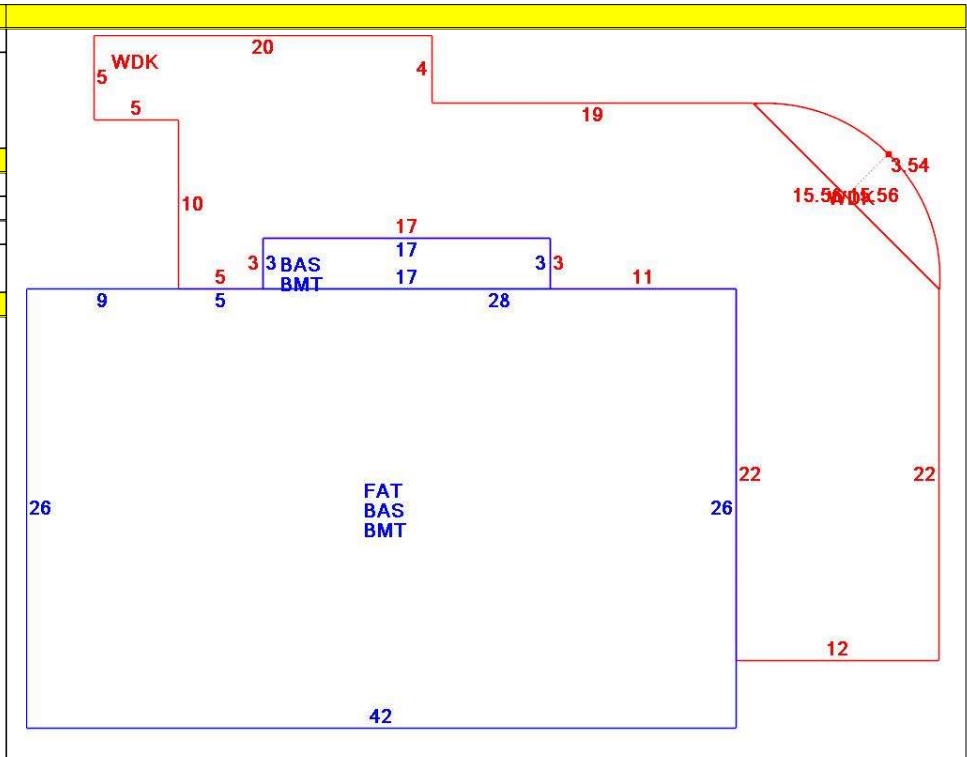

OB - OUTBUILDING & YARD ITEMS(L) / XF - BUILDING EXTRA FEATURES(B)

Code	Description	L/B	Units	Unit Price	Yr Blt	Cond. Cd	% Gd	Grade	Grade Adj.	Appr. Value
FPL2	Fireplace 1.5 s	B	1	6000.00	1998		82		0.00	4,900
WDC	Wood Decking	L	770	20.00	1998		58		0.00	8,100
BMT	Basement-Unfi	B	1,143	26.01	1998		82		0.00	23,800

BUILDING SUB-AREA SUMMARY SECTION

Code	Description	Living Area	Floor Area	Eff Area	Unit Cost	Undeprec Value
BAS	First Floor	1,143	1,143	1,143	258.35	295,294
BMT	Basement Area	0	1,143	0	0.00	0
FAT	Attic, Finished	164	1,092	164	38.80	42,369
WDK	Wood Deck	0	771	0	0.00	0
Ttl Gross Liv / Lease Area		1,307	4,149	1,307		337,663

