

| CURRENT OWNER | | TOPO | UTILITIES | STRT / ROAD | LOCATION | CURRENT ASSESSMENT | | | | |
|---|--|------|--------------|-------------|--|-----------------------|--------------|----------------------|----------------------|-----------|
| SWINDELLS, THOMAS RECK & CHA 52 LOVELL'S ROAD COTUIT MA 02635 | | 2 | Above Street | 2 | Public Water | RESIDENTL RES LAND | 1010 1010 | 1,242,200 166,300 | 1,242,200 166,300 | |
| | | 4 | Gas | 1 | Paved | | | | | |
| | | 6 | Septic | | | | | | | |
| SUPPLEMENTAL DATA | | | | | | | | | | |
| Alt Prcl ID Split Zonin BID Parcel ResExpt Q YES: #DL 1 LOT 2 #DL 2 GIS ID F_946243_2697323 | | | | | Plan Ref. 282/27 Land Ct# #SR Life Estate PP STATU Assoc Pid# | | Total | | 1,408,500 | 1,408,500 |

801
 FY2024
 BARNSTABLE, MA
VISION

| RECORD OF OWNERSHIP | | BK-VOL/PAGE | SALE DATE | Q/U | V/I | SALE PRIC | VC | PREVIOUS ASSESSMENTS (HISTORY) | | | | | | | | |
|----------------------------------|--|-------------|------------|-----|-----|-----------|----|--------------------------------|------|-----------|-------|------|-----------|-------|------|----------|
| SWINDELLS, THOMAS RECK & CHAN, C | | 33524 0004 | 11-30-2020 | Q | I | 799,987 | 00 | Year | Code | Assessed | Year | Code | Assessed | Year | Code | Assessed |
| BAIRD, JESSIE C | | 30674 0142 | 08-03-2017 | U | I | 665,000 | 1J | 2023 | 1010 | 1,079,200 | 2022 | 1010 | 915,700 | 2021 | 1010 | 713,900 |
| FAY, PAULA E & DIANE M | | 20136 0333 | 08-09-2005 | U | I | 1 | 1A | | 1010 | 151,100 | | 1010 | 112,000 | | 1010 | 112,000 |
| FAY, PAULA E & DIANE M TRS | | 17238 0064 | 07-11-2003 | U | I | 1 | 1A | | | | | | | | 1010 | 47,400 |
| FAY, PAULA E & DIANE M | | 8426 0087 | 01-15-1993 | U | I | 112,000 | A | Total | | 1,230,300 | Total | | 1,027,700 | Total | | 873,300 |

| EXEMPTIONS | | | | OTHER ASSESSMENTS | | | |
|------------|------|-----------------------|--------|-------------------|-------------|--------|--------|
| Year | Code | Description | Amount | Code | Description | Number | Amount |
| 2022 | 5C | RESIDENTIAL EXEMPTION | 0.00 | | | | |
| Total | | | 0.00 | | | | |

This signature acknowledges a visit by a Data Collector or Assessor

| ASSESSING NEIGHBORHOOD | | | |
|------------------------|-----------|---|---------|
| Nbhd | Nbhd Name | B | Tracing |
| 0105 | | | COTUIT |

| APPRAISED VALUE SUMMARY | |
|-------------------------------|-----------|
| Appraised Bldg. Value (Card) | 1,008,900 |
| Appraised Xf (B) Value (Bldg) | 183,200 |
| Appraised Ob (B) Value (Bldg) | 50,100 |
| Appraised Land Value (Bldg) | 166,300 |
| Special Land Value | 0 |
| Total Appraised Parcel Value | 1,408,500 |
| Valuation Method | C |
| Total Appraised Parcel Value | 1,408,500 |

| NOTES | | | | | | | |
|-------|--|--|--|--|--|--|--|
| | | | | | | | |

| BUILDING PERMIT RECORD | | | | | | | | | VISIT / CHANGE HISTORY | | | | | |
|------------------------|------------|------|----------------|---------|------------|--------|------------|---------------------------------|------------------------|----|------|----|----|-----------------------|
| Permit Id | Issue Date | Type | Description | Amount | Insp Date | % Comp | Date Comp | Comments | Date | Id | Type | Is | Cd | Purpost/Result |
| EXPR-22-8 | 01-04-2022 | 835 | Sid/Wind/Roof/ | 5,565 | | 100 | | insulation and air sealing work | 07-22-2021 | PK | 03 | | 16 | In Office Review |
| 201308975 | 12-06-2013 | PV | Solar PV Syste | 53,538 | 03-28-2014 | 100 | 06-30-2014 | 46 SOLAR PV PANELS ROOF | 07-09-2021 | TR | 03 | | 16 | In Office Review |
| 200903630 | 08-19-2009 | OB | Out Building | 5,000 | 10-27-2009 | 100 | 06-30-2011 | 14X16 SHED W ELEC | 12-10-2020 | SR | 01 | | 03 | Cycl Insp Comp |
| 200703103 | 06-15-2007 | SP | Swimming Pool | 2,700 | 06-30-2007 | 100 | 06-30-2007 | POOL 14X30 | 06-11-2020 | WD | | | | FR Field Review |
| 86209 | 08-17-2005 | AD | Addition | 429,000 | 05-16-2006 | 100 | 06-30-2007 | 2ND FLR-ADD'N W FIN 8X66 | 03-28-2014 | MW | 01 | | 02 | Bldg Permit Completed |
| B25013 | 04-01-1983 | DW | Dwelling | 0 | 01-15-1984 | 100 | 06-30-1984 | CO 1 ST | 09-20-2013 | RB | 03 | | 03 | Cycl Insp Comp |
| | | | | | | | | | 10-27-2009 | MK | 02 | | 52 | New Construction |

| LAND LINE VALUATION SECTION | | | | | | | | | | | | | | | | | |
|-----------------------------|----------|----------------|------|----|------------|------------|------------------------|---------|------------|-------|-------|-----------|------------------|--------------------|------------|------------|---------|
| B | Use Code | Description | Zone | LA | Land Units | Unit Price | Size Adj | AC Disc | Site Index | Cond. | Nbhd. | Nbhd. Adj | Notes | Location Adjustmen | Adj Unit P | Land Value | |
| 1 | 1010 | Single Fam M-0 | RF | 2 | 0.620 | AC | 176,344.00 | 1.52068 | 1.0000 | 5 | 1.00 | 0105 | 1.000 | | 1.0000 | 268,166.3 | 166,300 |
| Total Card Land Units | | | | | 0.62 | AC | Parcel Total Land Area | | | | | 0.62 | Total Land Value | | | 166,300 | |

| CONSTRUCTION DETAIL | | | CONSTRUCTION DETAIL (CONTINUED) | | |
|---------------------|----|----------------|--------------------------------------|----|-------------|
| Element | Cd | Description | Element | Cd | Description |
| Style | 03 | Colonial | | | |
| Model | 01 | Residential | | | |
| Grade: | C+ | Average Plus | | | |
| Stories | 2 | 2 Stories | | | |
| Exterior Wall 1 | 25 | Vinyl Siding | | | |
| Exterior Wall 2 | | | | | |
| RooF Structure | 03 | Gable/Hip | | | |
| RooF Cover | 03 | Asph/F Gls/Cmp | | | |
| Interior Wall 1 | 05 | Drywall | | | |
| Interior Wall 2 | | | | | |
| Interior Floor 1 | 12 | Hardwood | | | |
| Interior Floor 2 | | | | | |
| Heat Fuel | 03 | Gas | | | |
| Heat Type | 05 | Hot Water | | | |
| AC Type | 03 | Central | | | |
| Bedrooms | 05 | 5 Bedrooms | | | |
| Full Baths | 5 | | | | |
| Half Baths | 3 | | | | |
| Extra Fixtures | | | | | |
| Total Rooms | 12 | | | | |
| Bath Style | | | | | |
| Kitchen Style | | | | | |
| Occupancy | | | | | |
| Usrflid 105 | | | | | |
| Accessory Apt | | | | | |
| Foundation Alt | 01 | Poured Conc. | | | |
| Rms Prts | | | | | |
| Bath Split | 53 | 5 Full-3 Half | | | |
| | | | CONDO DATA | | |
| | | | Parcel Id | C | Ownr 0.0 |
| | | | Adjust Type Code Description Factor% | | |
| | | | Condo Flr | | |
| | | | Condo Unit | | |
| | | | COST / MARKET VALUATION | | |
| | | | Building Value New 1,096,677 | | |
| | | | Year Built 2006 | | |
| | | | Effective Year Built 2009 | | |
| | | | Depreciation Code A | | |
| | | | Remodel Rating | | |
| | | | Year Remodeled | | |
| | | | Depreciation % 8 | | |
| | | | Functional Obsol 0 | | |
| | | | External Obsol 0 | | |
| | | | Trend Factor 1 | | |
| | | | Condition | | |
| | | | Condition % | | |
| | | | Percent Good 92 | | |
| | | | RCNLD 1,008,900 | | |
| | | | Dep % Ovr | | |
| | | | Dep Ovr Comment | | |
| | | | Misc Imp Ovr | | |
| | | | Misc Imp Ovr Comment | | |
| | | | Cost to Cure Ovr | | |
| | | | Cost to Cure Ovr Comment | | |

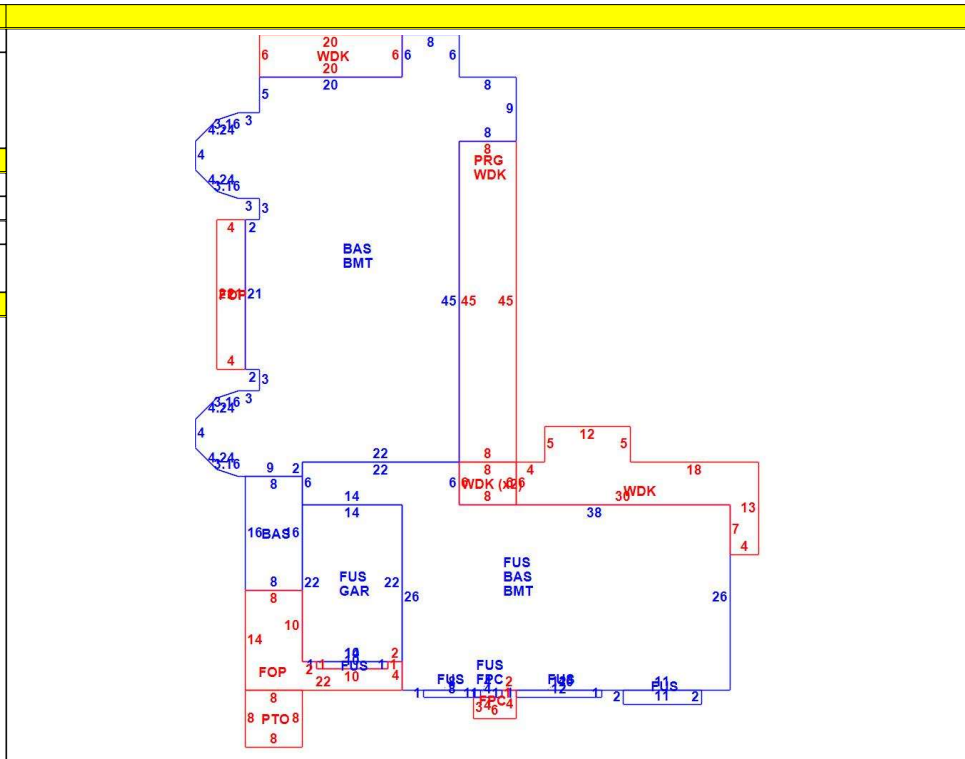

| OB - OUTBUILDING & YARD ITEMS(L) / XF - BUILDING EXTRA FEATURES(B) | | | | | | | | | | |
|--|-----------------|-----|-------|------------|--------|----------|------|-------|------------|-------------|
| Code | Description | L/B | Units | Unit Price | Yr Blt | Cond. Cd | % Gd | Grade | Grade Adj. | Appr. Value |
| FPL3 | Fireplace 2 sto | B | 1 | 7000.00 | 2011 | | 92 | | 0.00 | 6,400 |
| BFA1 | Bsmt Fin-Goo | B | 3,012 | 32.56 | 2011 | | 92 | | 0.00 | 90,200 |
| SPL2 | Pool Vinyl | L | 420 | 55.00 | 2007 | | 76 | 00 | 1.00 | 18,400 |
| WDC | Wood Decking | L | 868 | 20.00 | 2009 | | 80 | | 0.00 | 12,500 |
| PAT2 | Patio-Good | L | 64 | 9.94 | 2009 | | 90 | | 0.00 | 700 |
| FOP | Open Porch-ro | B | 242 | 55.00 | 2011 | | 92 | | 0.00 | 9,300 |
| GAR | Attached Gara | B | 308 | 40.00 | 2011 | | 92 | | 0.00 | 12,500 |
| BMT | Basement-Unfi | B | 3,194 | 26.01 | 2011 | | 92 | | 0.00 | 60,900 |
| PAT2 | Patio-Good | L | 520 | 9.94 | 2009 | | 90 | | 0.00 | 4,500 |
| FOPC | Open Prch-roo | B | 24 | 55.00 | 2011 | | 92 | | 0.00 | 1,600 |

| BUILDING SUB-AREA SUMMARY SECTION | | | | | | |
|-----------------------------------|------------------------|-------------|------------|----------|-----------|----------------|
| Code | Description | Living Area | Floor Area | Eff Area | Unit Cost | Undeprec Value |
| BAS | First Floor | 3,322 | 3,322 | 3,322 | 218.37 | 725,432 |
| BMT | Basement Area | 0 | 3,194 | 0 | 0.00 | 0 |
| FOP | Open Porch | 0 | 242 | 0 | 0.00 | 0 |
| FPC | Open Porch Conc. Floor | 0 | 24 | 0 | 0.00 | 0 |
| FUS | Upper Story | 1,692 | 1,692 | 1,692 | 218.37 | 369,485 |
| GAR | Attached Garage | 0 | 308 | 0 | 0.00 | 0 |
| PRG | Pergola | 0 | 360 | 0 | 0.00 | 0 |
| PTO | Patio | 0 | 64 | 0 | 0.00 | 0 |
| WDK | Wood Deck | 0 | 868 | 0 | 0.00 | 0 |
| Ttl Gross Liv / Lease Area | | 5,014 | 10,074 | 5,014 | | 1,094,917 |



| CURRENT OWNER | | TOPO | UTILITIES | STRT / ROAD | LOCATION | CURRENT ASSESSMENT | | | |
|---|--|------|--------------|--|--------------|----------------------|--------------|----------------------|----------------------|
| SWINDELLS, THOMAS RECK & CHA 52 LOVELL'S ROAD COTUIT MA 02635 | | 2 | Above Street | 2 | Public Water | RESIDNTL RES LAND | 1010 1010 | 1,242,200 166,300 | 1,242,200 166,300 |
| | | 4 | Gas | 1 | Paved | | | | |
| | | 6 | Septic | | | | | | |
| SUPPLEMENTAL DATA | | | | | | Total | | | |
| Alt Prcl ID Split Zonin BID Parcel ResExpt Q YES: #DL 1 LOT 2 #DL 2 GIS ID F_946243_2697323 | | | | Plan Ref. 282/27 Land Ct# #SR Life Estate PP STATU Assoc Pid# | | 1,408,500 1,408,500 | | | |

801
 FY2024
 BARNSTABLE, MA

VISION

| RECORD OF OWNERSHIP | | BK-VOL/PAGE | SALE DATE | Q/U | V/I | SALE PRIC | VC | PREVIOUS ASSESSMENTS (HISTORY) | | | | | |
|---------------------|------|-------------|-----------|------|------------|-----------|------|--------------------------------|--|--|--|--|--|
| Year | Code | Assessed | Year | Code | Assessed V | Year | Code | Assessed | | | | | |
| 2023 | 1010 | 1,079,200 | 2022 | 1010 | 915,700 | 2021 | 1010 | 713,900 | | | | | |
| | 1010 | 151,100 | | 1010 | 112,000 | | 1010 | 112,000 | | | | | |
| | | | | | | | 1010 | 47,400 | | | | | |
| Total | | 1,230,300 | Total | | 1,027,700 | Total | | 873,300 | | | | | |

| EXEMPTIONS | | | | OTHER ASSESSMENTS | | | |
|------------|------|-------------|--------|---|-------------|--------|--------|
| Year | Code | Description | Amount | Code | Description | Number | Amount |
| Total | | | | This signature acknowledges a visit by a Data Collector or Assessor | | | |

| ASSESSING NEIGHBORHOOD | | | |
|------------------------|-----------|---|---------|
| Nbhd | Nbhd Name | B | Tracing |
| 0105 | | | COTUIT |

| NOTES | | | |
|-------|--|--|--|
| | | | |

| BUILDING PERMIT RECORD | | | | | | | | VISIT / CHANGE HISTORY | | | | | | |
|------------------------|------------|------|-------------|--------|-----------|--------|-----------|------------------------|------|----|------|----|----|----------------|
| Permit Id | Issue Date | Type | Description | Amount | Insp Date | % Comp | Date Comp | Comments | Date | Id | Type | Is | Cd | Purpost/Result |
| | | | | | | | | | | | | | | |

| LAND LINE VALUATION SECTION | | | | | | | | | | | | | | | | |
|-----------------------------|----------|-------------|------|----|------------------------|------------|----------|---------|------------|------------------|-------|-----------|-------|--------------------|------------|------------|
| B | Use Code | Description | Zone | LA | Land Units | Unit Price | Size Adj | AC Disc | Site Index | Cond. | Nbhd. | Nbhd. Adj | Notes | Location Adjustmen | Adj Unit P | Land Value |
| | | | | | | | | | | | | | | | | |
| Total Card Land Units | | | | | Parcel Total Land Area | | | | | Total Land Value | | | | | | |

| CONSTRUCTION DETAIL | | | | | | CONSTRUCTION DETAIL (CONTINUED) | | | | | |
|---|----------------|----------------|------------|------------|-----------|---------------------------------|------|-------------|------------|-------------|-----|
| Element | Cd | Description | | | | Element | Cd | Description | | | |
| Style | 03 | Colonial | | | | | | | | | |
| Model | 01 | Residential | | | | | | | | | |
| Grade: | C+ | Average Plus | | | | | | | | | |
| Stories | 2 | 2 Stories | | | | | | | | | |
| Exterior Wall 1 | 25 | Vinyl Siding | | | | CONDO DATA | | | | | |
| Exterior Wall 2 | | | | | | Parcel Id | | C | | Ownr | 0.0 |
| Roof Structure | 03 | Gable/Hip | | | | | | B | | S | |
| Roof Cover | 03 | Asph/F Gls/Cmp | | | | Adjust Type | Code | Description | | Factor% | |
| Interior Wall 1 | 05 | Drywall | | | | Condo Flr | | | | | |
| Interior Wall 2 | | | | | | Condo Unit | | | | | |
| Interior Floor 1 | 12 | Hardwood | | | | COST / MARKET VALUATION | | | | | |
| Interior Floor 2 | | | | | | Building Value New | | | | | |
| Heat Fuel | 03 | Gas | | | | Year Built | | | | | |
| Heat Type | 05 | Hot Water | | | | Effective Year Built | | | | | |
| AC Type | 03 | Central | | | | Depreciation Code | | | | | |
| Bedrooms | 05 | 5 Bedrooms | | | | Remodel Rating | | | | | |
| Full Baths | 5 | | | | | Year Remodeled | | | | | |
| Half Baths | 3 | | | | | Depreciation % | | | | | |
| Extra Fixtures | | | | | | Functional Obsol | | | | | |
| Total Rooms | 12 | | | | | External Obsol | | | | | |
| Bath Style | | | | | | Trend Factor | | | | | |
| Kitchen Style | | | | | | Condition | | | | | |
| Occupancy | | | | | | Condition % | | | | | |
| Usrflid 105 | | | | | | Percent Good | | | | | |
| Accessory Apt | | | | | | RCNLD | | | | | |
| Foundation Alt | 01 | Poured Conc. | | | | Dep % Ovr | | | | | |
| Rms Prts | | | | | | Dep Ovr Comment | | | | | |
| Bath Split | 53 | 5 Full-3 Half | | | | Misc Imp Ovr | | | | | |
| | | | | | | Misc Imp Ovr Comment | | | | | |
| | | | | | | Cost to Cure Ovr | | | | | |
| | | | | | | Cost to Cure Ovr Comment | | | | | |
| OB - OUTBUILDING & YARD ITEMS(L) / XF - BUILDING EXTRA FEATURES(B) | | | | | | | | | | | |
| Code | Description | L/B | Units | Unit Price | Yr Blt | Cond. Cd | % Gd | Grade | Grade Adj. | Appr. Value | |
| SHD2 | Shed w/Elec | L | 224 | 26.00 | 2009 | | 80 | | 0.00 | 4,700 | |
| SPH1 | Pool Heater < | L | 1 | 2434.00 | 2007 | | 76 | | 0.00 | 1,800 | |
| PAT1 | Patio- Average | L | 1,036 | 5.89 | 2007 | | 88 | | 0.00 | 4,800 | |
| SOL2 | Solar PV Pane | B | 46 | 725.00 | 2011 | | 0 | | 0.00 | 0 | |
| FPIT | Fire Pit | L | 1 | 3010.00 | 2009 | | 90 | C | 1.00 | 2,700 | |
| FPLG | Gas Fireplace- | B | 1 | 2500.00 | 2011 | | 92 | | 0.00 | 2,300 | |
| BUILDING SUB-AREA SUMMARY SECTION | | | | | | | | | | | |
| Code | Description | Living Area | Floor Area | Eff Area | Unit Cost | Undeprec Value | | | | | |
| | | | | | | | | | | | |
| Ttl Gross Liv / Lease Area | | | | | | | | | | | |