

| CURRENT OWNER | | TOPO | UTILITIES | STRT / ROAD | LOCATION | CURRENT ASSESSMENT | | | |
|---|--|---------|--------------|--|--------------|--------------------|------|-----------|-----------|
| HILTON, FREDERIC S & JUDITH A PO BOX 426 BARNSTABLE MA 02630 | | 1 Level | 1 All Public | 1 Paved | 7 Waterfront | Description | Code | Assessed | Assessed |
| | | | | | 1 Excel View | RESIDNTL | 1010 | 832,200 | 832,200 |
| | | | | | | RES LAND | 1010 | 1,954,600 | 1,954,600 |
| SUPPLEMENTAL DATA | | | | | | | | | |
| Alt Prcl ID Split Zonin BID Parcel ResExpt Q YES: #DL 1 LOT 22, 24 & 26 #DL 2 GIS ID F_986714_2721656 | | | | Plan Ref. 3/77 Land Ct# #SR Life Estate PP STATU Assoc Pid# | | | | | |
| | | | | | | Total | | 2,786,800 | 2,786,800 |

801
 FY2024
 BARNSTABLE, MA

VISION

| RECORD OF OWNERSHIP | | BK-VOL/PAGE | SALE DATE | Q/U | V/I | SALE PRIC | VC | PREVIOUS ASSESSMENTS (HISTORY) | | | | | |
|-----------------------------------|--|-------------|------------|-----|-----|-----------|----|--------------------------------|-----------|-----------|-----------|-------|-----------|
| HILTON, FREDERIC S & JUDITH A | | 24810 0152 | 09-08-2010 | U | I | 1 | 1F | Year | Code | Assessed | Year | Code | Assessed |
| HILTON, FREDERIC S & JUDITH A TRS | | 24384 0066 | 02-25-2010 | U | I | 1 | 1F | 2023 | 1010 | 744,800 | 2022 | 1010 | 630,300 |
| HILTON, FREDERIC S & JUDITH A | | 24331 0057 | 01-28-2010 | U | I | 1 | 1F | | 1010 | 2,517,300 | | 1010 | 1,288,800 |
| HILTON, FREDERIC S & JUDITH A TRS | | 18648 0020 | 05-27-2004 | U | I | 0 | 1F | | | | | 1010 | 20,900 |
| HILTON, FREDERIC S & JUDITH A | | 18647 0344 | 05-27-2004 | U | I | 0 | 1A | | | | | | |
| | | | | | | | | Total | 3,262,100 | Total | 1,919,100 | Total | 1,825,500 |

| EXEMPTIONS | | | | OTHER ASSESSMENTS | | | |
|------------|------|-----------------------|--------|-------------------|-------------|--------|--------|
| Year | Code | Description | Amount | Code | Description | Number | Amount |
| 2022 | 5C | RESIDENTIAL EXEMPTION | | | | | |
| | | | Total | 0.00 | | | |

This signature acknowledges a visit by a Data Collector or Assessor

| ASSESSING NEIGHBORHOOD | | | | APPRAISED VALUE SUMMARY | | | |
|------------------------|-----------|---|---------|-------------------------------|-----------|--|--|
| Nbhd | Nbhd Name | B | Tracing | Batch | | | |
| 0119 | | | | BARNS | | | |
| NOTES | | | | Appraised Bldg. Value (Card) | 749,300 | | |
| | | | | Appraised Xf (B) Value (Bldg) | 62,000 | | |
| | | | | Appraised Ob (B) Value (Bldg) | 20,900 | | |
| | | | | Appraised Land Value (Bldg) | 1,954,600 | | |
| | | | | Special Land Value | 0 | | |
| | | | | Total Appraised Parcel Value | 2,786,800 | | |
| | | | | Valuation Method | C | | |
| | | | | Total Appraised Parcel Value | 2,786,800 | | |

| BUILDING PERMIT RECORD | | | | | | | | | VISIT / CHANGE HISTORY | | | | | |
|------------------------|------------|------|--------------|---------|------------|--------|------------|-----------------------------|------------------------|----|------|----|----|-----------------------|
| Permit Id | Issue Date | Type | Description | Amount | Insp Date | % Comp | Date Comp | Comments | Date | Id | Type | Is | Cd | Purpost/Result |
| 20-314 | 02-03-2020 | 834 | Sheet Metal | 5,000 | 05-28-2020 | 100 | 06-30-2020 | Duct work | 12-22-2021 | AS | 03 | | 16 | In Office Review |
| 19-3651 | 11-06-2019 | 827 | New Const-De | 400,000 | 05-28-2020 | 100 | 06-30-2020 | construct a new 4 bedroom 3 | 07-02-2020 | CK | 22 | | 22 | Change of Address |
| 19-3650 | 11-06-2019 | 810 | Demolition | 10,000 | 05-28-2020 | 100 | 06-30-2020 | demo existing dwelling | 06-04-2020 | DM | | | FR | Field Review |
| | | | | | | | | | 05-28-2020 | SR | 01 | | 02 | Bldg Permit Completed |
| | | | | | | | | | 12-02-2016 | AL | 22 | | 22 | Change of Address |
| | | | | | | | | | 09-14-2016 | SR | 02 | | 03 | Cycl Insp Comp |
| | | | | | | | | | 07-08-2014 | JR | 03 | | 16 | In Office Review |

| LAND LINE VALUATION SECTION | | | | | | | | | | | | | | | | |
|-----------------------------|----------|----------------|------|----|-----------------------|------------|----------|------------------------|------------|-------|-------|-----------|------------|--------------------|------------------|------------|
| B | Use Code | Description | Zone | LA | Land Units | Unit Price | Size Adj | AC Disc | Site Index | Cond. | Nbhd. | Nbhd. Adj | Notes | Location Adjustmen | Adj Unit P | Land Value |
| 1 | 1010 | Single Fam M-0 | RF-1 | 1 | 0.570 AC | 176,344.00 | 1.62049 | 1.0000 | 5 | 1.00 | 0119 | 12.000 | WATERFRONT | | 1.0000 | 3,429,167 |
| | | | | | Total Card Land Units | 0.57 | AC | Parcel Total Land Area | | | | | 0.57 | | | |
| | | | | | | | | | | | | | | | Total Land Value | 1,954,600 |

| CONSTRUCTION DETAIL | | | CONSTRUCTION DETAIL (CONTINUED) | | |
|---------------------|------|---------------|---------------------------------|----|-------------|
| Element | Cd | Description | Element | Cd | Description |
| Style | 04 | Cape Cod | | | |
| Model | 01 | Residential | | | |
| Grade: | B- | Custom Minus | | | |
| Stories | 1.75 | 1 3/4 Stories | | | |
| Exterior Wall 1 | 14 | Wood Shingle | | | |
| Exterior Wall 2 | | | | | |
| RooF Structure | 03 | Gable/Hip | | | |
| RooF Cover | 10 | Wood Shingle | | | |
| Interior Wall 1 | 05 | Drywall | | | |
| Interior Wall 2 | | | | | |
| Interior Floor 1 | 12 | Hardwood | | | |
| Interior Floor 2 | | | | | |
| Heat Fuel | 03 | Gas | | | |
| Heat Type | 04 | Hot Air | | | |
| AC Type | 03 | Central | | | |
| Bedrooms | 04 | 4 Bedrooms | | | |
| Full Baths | 3 | | | | |
| Half Baths | 1 | | | | |
| Extra Fixtures | | | | | |
| Total Rooms | 7 | | | | |
| Bath Style | | | | | |
| Kitchen Style | | | | | |
| Occupancy | | | | | |
| Usrflid 105 | | | | | |
| Accessory Apt | | | | | |
| Foundation Alt | 01 | Poured Conc. | | | |
| Rms Prts | | | | | |
| Bath Split | 31 | 3 Full-1 Half | | | |

| CONDO DATA | | | |
|-------------|------|-------------|----------|
| Parcel Id | | C | Owne 0.0 |
| Adjust Type | Code | Description | Factor% |
| Condo Flr | | | |
| Condo Unit | | | |

| COST / MARKET VALUATION | | |
|--------------------------|--|---------|
| Building Value New | | 764,600 |
| Year Built | | 2019 |
| Effective Year Built | | 2017 |
| Depreciation Code | | A |
| Remodel Rating | | |
| Year Remodeled | | |
| Depreciation % | | 2 |
| Functional Obsol | | 0 |
| External Obsol | | 0 |
| Trend Factor | | 1 |
| Condition | | |
| Condition % | | |
| Percent Good | | 98 |
| RCNLD | | 749,300 |
| Dep % Ovr | | |
| Dep Ovr Comment | | |
| Misc Imp Ovr | | |
| Misc Imp Ovr Comment | | |
| Cost to Cure Ovr | | |
| Cost to Cure Ovr Comment | | |

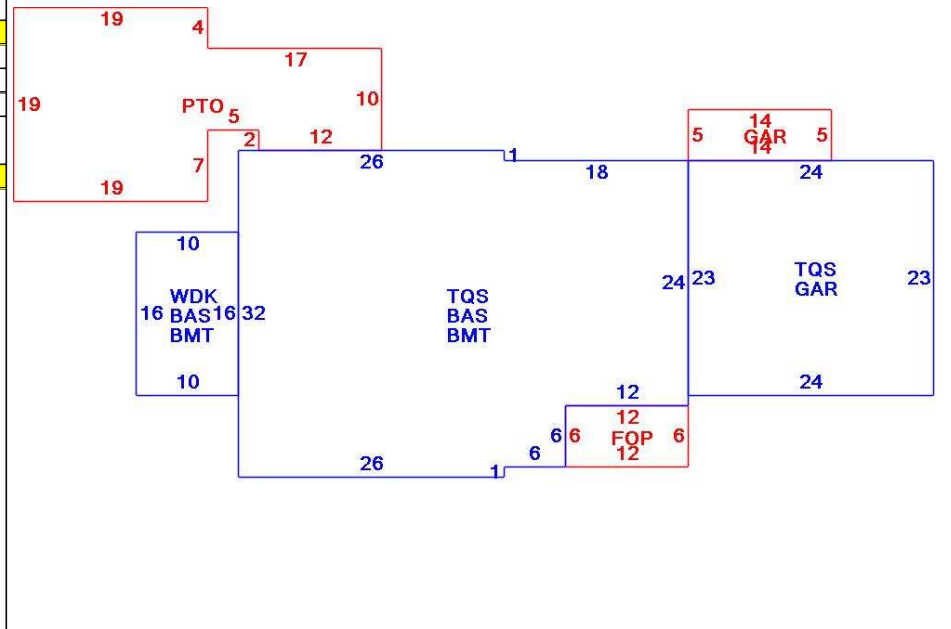

| OB - OUTBUILDING & YARD ITEMS(L) / XF - BUILDING EXTRA FEATURES(B) | | | | | | | | | | |
|--|----------------|-----|-------|------------|--------|----------|------|-------|------------|-------------|
| Code | Description | L/B | Units | Unit Price | Yr Blt | Cond. Cd | % Gd | Grade | Grade Adj. | Appr. Value |
| WDC | Wood Decking | L | 160 | 20.00 | 2019 | | 100 | | 0.00 | 4,200 |
| PATC | Conc Pavers | L | 521 | 15.46 | 2019 | | 100 | | 0.00 | 7,800 |
| FPIT | Fire Pit | L | 1 | 3010.00 | 2019 | | 100 | C+ | 1.10 | 3,300 |
| GEN | Emergency Ge | L | 1 | 5550.00 | 2019 | | 100 | | 0.00 | 5,600 |
| BMT | Basement-Unfi | B | 1,460 | 26.01 | 2019 | | 98 | | 0.00 | 34,100 |
| FOP | Open Porch-ro | B | 72 | 55.00 | 2019 | | 98 | | 0.00 | 4,300 |
| GAR | Attached Gara | B | 622 | 40.00 | 2019 | | 98 | | 0.00 | 21,100 |
| FPLG | Gas Fireplace- | B | 1 | 2500.00 | 2019 | | 98 | | 0.00 | 2,500 |

| BUILDING SUB-AREA SUMMARY SECTION | | | | | | |
|-----------------------------------|---------------------|-------------|------------|----------|-----------|----------------|
| Code | Description | Living Area | Floor Area | Eff Area | Unit Cost | Undeprec Value |
| BAS | First Floor | 1,460 | 1,460 | 1,460 | 287.01 | 419,038 |
| BMT | Basement Area | 0 | 1,460 | 0 | 0.00 | 0 |
| FOP | Open Porch | 0 | 72 | 0 | 0.00 | 0 |
| GAR | Attached Garage | 0 | 622 | 0 | 0.00 | 0 |
| PTO | Patio | 0 | 521 | 0 | 0.00 | 0 |
| TQS | Three Quarter Story | 1,204 | 1,852 | 1,204 | 186.59 | 345,562 |
| WDK | Wood Deck | 0 | 160 | 0 | 0.00 | 0 |
| Ttl Gross Liv / Lease Area | | 2,664 | 6,147 | 2,664 | | 764,600 |

