

CURRENT OWNER		TOPO	UTILITIES	STRT / ROAD	LOCATION	CURRENT ASSESSMENT						801 FY2024 BARNSTABLE, MA VISION						
PATERSON, DONNA J						Description	Code	Assessed	Assessed									
804 SOUTH STREET						RESIDNTL	1020	610,100	610,100									
HOLBROOK MA 02343		SUPPLEMENTAL DATA				Total		610,100	610,100									
Alt Prcl ID Split Zonin BID Parcel ResExpt Q #DL 1 UNIT B1 #DL 2 BLDG B GIS ID F_989130_2694553		Plan Ref. Land Ct# 14934-E-1 LOT 4 #SR Life Estate PP STATU Assoc Pid#																
RECORD OF OWNERSHIP		BK-VOL/PAGE	SALE DATE	Q/U	V/I	SALE PRICE	VC	PREVIOUS ASSESSMENTS (HISTORY)										
PATERSON, DONNA J		C34-B 0	07-21-2021	U	I	620,000	1	Year	Code	Assessed	Year	Code	Assessed	Year	Code	Assessed		
MARTIN, NANCY A		C34-B 0	10-02-2015	Q	I	487,500	00	2023	1020	509,200	2022	1020	494,400	2021	1020	498,500		
BURNELL, AIDAN M & ELISABETH		C34-B 0	11-29-2002	Q	I	425,000	00								1020	2,100		
CONRAD, DONALD B & MARY J		C34-B 0	05-31-2000	Q	I	295,000	00											
BENJAMIN, KENNETH F & GLORIA		C34-B 0	01-15-1995	Q	I	165,000	00											
		Total				509,200		Total		494,400	Total		500,600					
EXEMPTIONS			OTHER ASSESSMENTS				This signature acknowledges a visit by a Data Collector or Assessor											
Year	Code	Description	Amount	Code	Description	Number	Amount	Comm Int										
Total		0.00																
ASSESSING NEIGHBORHOOD																		
Nbhd	Nbhd Name	B		Tracing				Batch										
0001								HYAN										
NOTES																		
BUILDING PERMIT RECORD										VISIT / CHANGE HISTORY								
Permit Id	Issue Date	Type	Description	Amount	Insp Date	% Comp	Date Comp	Comments			Date	Id	Type	Is	Cd	Purpost/Result		
18-1401	05-08-2018	835	Sid/Wind/Roof/	3,900		100		replace 1 window - barnstable			01-26-2022	BM	03		16	In Office Review		
											05-11-2020	WD			FR	Field Review		
											04-13-2015	TP	02		03	Cycl Insp Comp		
LAND LINE VALUATION SECTION																		
B	Use Code	Description	Zone	Dist	Land Type	Land Units	Unit Price	Size Adj	Site Index	Cond.	Nbhd.	Nbhd. Adj	Notes		Location Adjustmen	Adj Unit P	Land Value	
1	102U	Condominium M	RB	4		0 SF	0.00	1.00000	5	1.00	0001	1.000			0.0000	0	0	
Total Card Land Units						0 SF	Parcel Total Land Area						0.00	Total Land Value				0

CONSTRUCTION DETAIL			CONSTRUCTION DETAIL (CONTINUED)		
Element	Cd	Description	Element	Cd	Description
Style	55	Condominium			
Model	05	Res Condo			
Bedrm Func	C	Average			
Stories	1	1 Story			
Occupancy	0				
Interior Wall 1	08	Typical			
Interior Wall 2					
Interior Floor 1	20	Typical			
Interior Floor 2					
Heat Fuel	04	Electric			
Heat Type	07	Elec Baseboard			
AC Type	02	Heat Pump			
Bedrooms	02	2 Bedrooms			
Full Baths	1	1 Full			
Half Baths	1				
Extra Fixtures					
Total Rooms	4	4 Rooms			
Bath Style					
Kitchen Style					
Master Deed L	1112				
Bath Split	11	1 Full-1 Half			
Foundation	01	Poured Conc.			
AC Type Alt					
Sewer Occupan					
CONDO DATA					
Parcel Id	104265	C 0490	Own	14.	
	OCEAN GATE	B 1	S 1		
Adjust Type	Code	Description	Factor%		
Condo Flr	1FU	FIRST FLOOR	100		
Condo Unit	MKT0	MKT0	100		
COST / MARKET VALUATION					
Building Value New		764,618			
Year Built		1960			
Effective Year Built		1992			
Depreciation Code		A			
Remodel Rating					
Year Remodeled		21			
Depreciation %		0			
Functional Obsol		0			
External Obsol		1			
Trend Factor		79			
Condition		604,000			
Condition %					
Percent Good					
Cns Sect Rcnld					
Dep % Ovr					
Dep Ovr Comment					
Misc Imp Ovr					
Misc Imp Ovr Comment					
Cost to Cure Ovr					
Cost to Cure Ovr Comment					

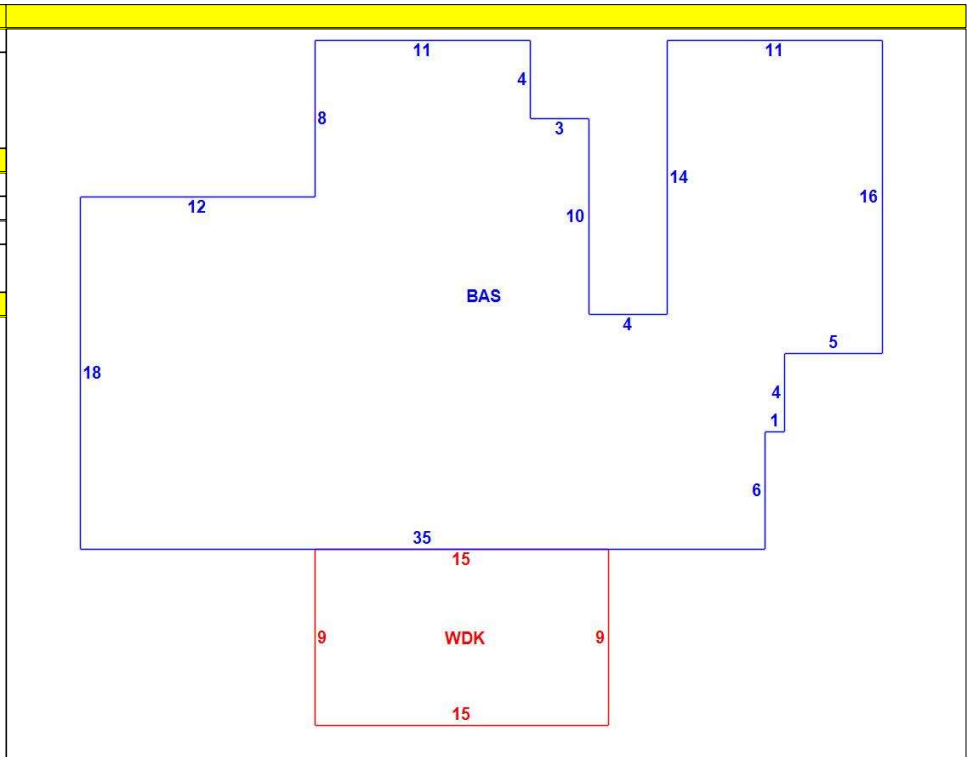

OB - OUTBUILDING & YARD ITEMS(L) / XF - BUILDING EXTRA FEATURES(B)										
Code	Description	L/B	Units	Unit Price	Yr Blt	Cond. Cd	% Gd	Grade	Grade Adj.	Appr. Value
FPL1	Fireplace 1 sto	B	1	5000.00	1994		79		0.00	4,000
WDC	Wood Decking	L	135	20.00	1995		52		0.00	2,100

BUILDING SUB-AREA SUMMARY SECTION						
Code	Description	Living Area	Floor Area	Eff Area	Unit Cost	Undeprec Value
BAS	First Floor	846	846	846	903.80	764,618
WDC	Wood Deck	0	135	0	0.00	0
Ttl Gross Liv / Lease Area		846	981	846		764,618

