

CURRENT OWNER		TOPO	UTILITIES	STRT / ROAD	LOCATION	CURRENT ASSESSMENT			
PAHARIK, BENJAMIN W & SARAH H 6 PIKE STREET HOPKINTON MA 01748-1819		2 Above Street	2 Public Water	1 Paved		Description	Code	Assessed	Assessed
			4 Gas			RESIDNTL	1010	373,200	373,200
			6 Septic			RES LAND	1010	155,900	155,900
SUPPLEMENTAL DATA									
Alt Prcl ID			Plan Ref. 282/27						
Split Zonin			Land Ct#						
BID Parcel			#SR						
ResExpt Q			Life Estate						
#DL 1 LOT 24			PP STATU						
#DL 2									
GIS ID F_947191_2697609			Assoc Pid#						
						Total		529,100	529,100

801
FY2024
BARNSTABLE, MA

VISION

RECORD OF OWNERSHIP		BK-VOL/PAGE	SALE DATE	Q/U	V/I	SALE PRIC	VC	PREVIOUS ASSESSMENTS (HISTORY)						
BLANKENSHIP, DUANGKAMOL		35875 60	07-05-2023	U	I	552,000	1F	Year	Code	Assessed	Year	Code	Assessed	
PAHARIK, BENJAMIN W & SARAH H		28340 0198	08-22-2014	Q	I	270,000	00	2023	1010	322,600	2022	1010	279,900	
NEWMAN, FREDERICK H & ANN M MED		7561 0250	06-15-1991	Q	I	115,000	U		1010	141,700		1010	105,000	
CARNEY, BEATRICE B		6046 0161	12-03-1987	U	I	0	H					1010	6,600	
CARNEY, ROBERT A & BEATRICE B		4248 0316	09-14-1984	U	I	72,500	O							
						Total		464,300	Total		384,900	Total		335,900

EXEMPTIONS			OTHER ASSESSMENTS					
Year	Code	Description	Amount	Code	Description	Number	Amount	Comm Int
Total			0.00					

This signature acknowledges a visit by a Data Collector or Assessor

ASSESSING NEIGHBORHOOD				
Nbhd	Nbhd Name	B	Tracing	Batch
0105				COTUIT

NOTES			

APPRAISED VALUE SUMMARY	
Appraised Bldg. Value (Card)	318,000
Appraised Xf (B) Value (Bldg)	47,700
Appraised Ob (B) Value (Bldg)	7,500
Appraised Land Value (Bldg)	155,900
Special Land Value	0
Total Appraised Parcel Value	529,100
Valuation Method	C
Total Appraised Parcel Value	529,100

BUILDING PERMIT RECORD									VISIT / CHANGE HISTORY					
Permit Id	Issue Date	Type	Description	Amount	Insp Date	% Comp	Date Comp	Comments	Date	Id	Type	Is	Cd	Purpost/Result
200902471	06-09-2009	RW	Repair Work	290,800	10-15-2009	100	06-30-2010	FIRE DMG	07-31-2021	BM	01		03	Cycl Insp Comp
B24678	12-01-1982	DW	Dwelling	0	01-15-1985	100	12-31-1985	CO 1 ST	06-11-2020	WD			FR	Field Review
									05-18-2016	JR	03		20	Sale Review
									09-20-2013	RB	03		03	Cycl Insp Comp
									05-12-2010	NF	03		02	Bldg Permit Completed
									10-15-2009	MK	01		52	New Construction
									03-08-2009	PT	01		00	Meas/Listed-Interior Acces

LAND LINE VALUATION SECTION																	
B	Use Code	Description	Zone	LA	Land Units	Unit Price	Size Adj	AC Disc	Site Index	Cond.	Nbhd.	Nbhd. Adj	Notes	Location Adjustmen	Adj Unit P	Land Value	
1	1010	Single Fam M-0	RF	2	0.460	AC	176,344.00	1.92125	1.0000	5	1.00	0105	1.000		1.0000	338,809.7	155,900
Total Card Land Units					0.46	AC	Parcel Total Land Area					0.46	Total Land Value			155,900	

CONSTRUCTION DETAIL			CONSTRUCTION DETAIL (CONTINUED)		
Element	Cd	Description	Element	Cd	Description
Style	01	Ranch			
Model	01	Residential			
Grade:	C	Average			
Stories	1	1 Story			
Exterior Wall 1	14	Wood Shingle			
Exterior Wall 2	06	Vertical Sidin			
Roof Structure	03	Gable/Hip			
Roof Cover	03	Asph/F Gls/Cmp			
Interior Wall 1	05	Drywall			
Interior Wall 2					
Interior Floor 1	12	Hardwood			
Interior Floor 2					
Heat Fuel	03	Gas			
Heat Type	05	Hot Water			
AC Type	03	Central			
Bedrooms	02	2 Bedrooms			
Full Baths	1				
Half Baths	1				
Extra Fixtures					
Total Rooms	6	6 Rooms			
Bath Style					
Kitchen Style					
Occupancy					
Usrflid 105					
Accessory Apt					
Foundation Alt	01	Poured Conc.			
Rms Prts					
Bath Split	11	1 Full-1 Half			

CONDO DATA				
Parcel Id		C	Ownr	0.0
Adjust Typ	Code	Description	Factor%	
Condo Flr				
Condo Unit				

COST / MARKET VALUATION	
Building Value New	349,459
Year Built	2003
Effective Year Built	2007
Depreciation Code	A
Remodel Rating	
Year Remodeled	
Depreciation %	9
Functional Obsol	0
External Obsol	0
Trend Factor	1
Condition	
Condition %	
Percent Good	91
RCNLD	318,000
Dep % Ovr	
Dep Ovr Comment	
Misc Imp Ovr	
Misc Imp Ovr Comment	
Cost to Cure Ovr	
Cost to Cure Ovr Comment	

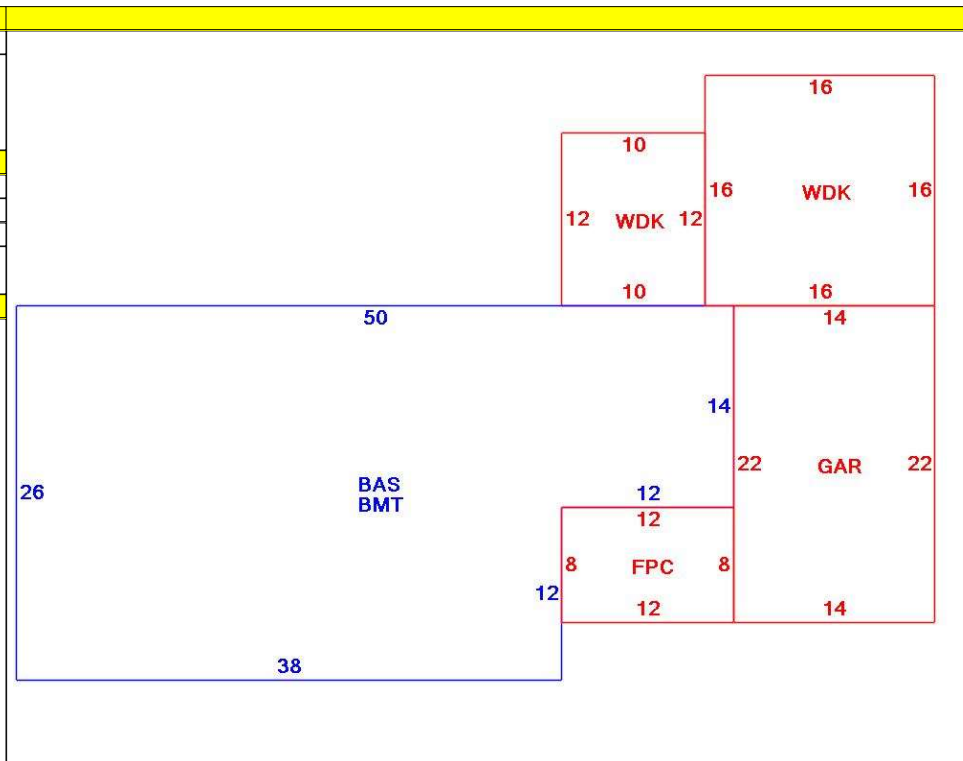

OB - OUTBUILDING & YARD ITEMS(L) / XF - BUILDING EXTRA FEATURES(B)										
Code	Description	L/B	Units	Unit Price	Yr Blt	Cond. Cd	% Gd	Grade	Grade Adj.	Appr. Value
FPL1	Fireplace 1 sto	B	1	5000.00	2009		91		0.00	4,600
WDC	Wood Decking	L	120	20.00	2007		76		0.00	2,900
FOPC	Open Prch-roo	B	96	55.00	2009		91		0.00	4,100
GAR	Attached Gara	B	308	40.00	2009		91		0.00	12,400
BMT	Basement-Unfi	B	1,156	26.01	2009		91		0.00	26,600
WDC	Wood Deck w/	L	256	18.00	2007		76		0.00	3,700
SHED	Shed	L	64	18.00	2009		80		0.00	900

BUILDING SUB-AREA SUMMARY SECTION						
Code	Description	Living Area	Floor Area	Eff Area	Unit Cost	Undeprec Value
BAS	First Floor	1,156	1,156	1,156	302.30	349,459
BMT	Basement Area	0	1,156	0	0.00	0
FPC	Open Porch Conc. Floor	0	96	0	0.00	0
GAR	Attached Garage	0	308	0	0.00	0
WDK	Wood Deck	0	376	0	0.00	0
Ttl Gross Liv / Lease Area		1,156	3,092	1,156		349,459

