

| CURRENT OWNER | | | | TOPO | UTILITIES | STRT / ROAD | LOCATION | CURRENT ASSESSMENT | | | | 801 FY2024 BARNSTABLE, MA VISION | |
|-------------------------------|--|--|--|--------------------------|--------------------------|-------------|-----------------|--------------------|------|-----------|-----------|--|----------------------|
| GOULA, BETH & OSTROWSKI, MELI | | | | 1 Level | 1 All Public | 1 Paved | 1 Lake/Pond Vie | Description | Code | Assessed | Assessed | | RESIDNTL RES LAND |
| 2 LARKSPUR LANE | | | | | | | | | 1010 | 293,100 | 293,100 | | |
| GREENWICH CT 06831 | | | | SUPPLEMENTAL DATA | | | | | | 1010 | 1,062,000 | 1,062,000 | |
| | | | | Alt Prcl ID | Split Zonin | Plan Ref. | 8/119 | | | | | | |
| | | | | BID Parcel | ResExpt Q | Land Ct# | #SR | | | | | | |
| | | | | #DL 1 | LOTS 179, 180, 181 & 182 | Life Estate | PP STATU | | | | | | |
| | | | | #DL 2 | | Assoc Pid# | | | | | | | |
| | | | | GIS ID | F_988851_2695087 | | | Total | | 1,355,100 | 1,355,100 | | |

| RECORD OF OWNERSHIP | | | | BK-VOL/PAGE | SALE DATE | Q/U | V/I | SALE PRIC | VC | PREVIOUS ASSESSMENTS (HISTORY) | | | | | | | | | |
|----------------------------------|--|--|--|-------------|-----------|------------|-----|-----------|----|--------------------------------|-----------|------|----------|------|---------|----------|-------|------|----------|
| GOULA, BETH & OSTROWSKI, MELINDA | | | | 28461 | 0323 | 10-23-2014 | U | I | 1 | 1F | Year | Code | Assessed | Year | Code | Assessed | Year | Code | Assessed |
| SCHEPPLER, DIANNE & GOULA, BETH | | | | 6109 | 0253 | 01-15-1988 | U | I | 1 | 1A | 2023 | 1010 | 261,000 | 2022 | 1010 | 220,700 | 2021 | 1010 | 185,200 |
| MULLER, PAUL J & SCHEPPLER, D& | | | | 5837 | 0114 | 07-15-1987 | U | I | 1 | 1A | | 1010 | 950,100 | | 1010 | 499,500 | | 1010 | 499,500 |
| MULLER, PAUL J | | | | 2880 | 0328 | 03-05-1979 | U | | 0 | | | | | | | | | 1010 | 4,500 |
| | | | | Total | | | | | | | 1,211,100 | | Total | | 720,200 | | Total | | 689,200 |

| EXEMPTIONS | | | | OTHER ASSESSMENTS | | | | This signature acknowledges a visit by a Data Collector or Assessor | | | | | | | | | | | | |
|------------|------|-------------|--------|-------------------|-------------|--------|--------|---|--|--|--|--|--|--|--|--|--|--|--|--|
| Year | Code | Description | Amount | Code | Description | Number | Amount | Comm Int | | | | | | | | | | | | |
| | | | | | | | | | | | | | | | | | | | | |
| Total | | | 0.00 | | | | | | | | | | | | | | | | | |

| ASSESSING NEIGHBORHOOD | | | | APPRAISED VALUE SUMMARY | | | | | | | |
|------------------------|-----------|---|---------|-------------------------|--|--|--|--|--|--|--|
| Nbhd | Nbhd Name | B | Tracing | Batch | | | | | | | |
| 0113 | | | | HYAN | | | | | | | |

| NOTES | | | | | | | | | | | | APPRAISED VALUE SUMMARY | | | | | |
|-------|--|--|--|--|--|--|--|--|--|--|--|-------------------------------|-----------|--|--|--|--|
| | | | | | | | | | | | | Appraised Bldg. Value (Card) | 253,300 | | | | |
| | | | | | | | | | | | | Appraised Xf (B) Value (Bldg) | 35,300 | | | | |
| | | | | | | | | | | | | Appraised Ob (B) Value (Bldg) | 4,500 | | | | |
| | | | | | | | | | | | | Appraised Land Value (Bldg) | 1,062,000 | | | | |
| | | | | | | | | | | | | Special Land Value | 0 | | | | |
| | | | | | | | | | | | | Total Appraised Parcel Value | 1,355,100 | | | | |
| | | | | | | | | | | | | Valuation Method | C | | | | |
| | | | | | | | | | | | | Total Appraised Parcel Value | 1,355,100 | | | | |

| BUILDING PERMIT RECORD | | | | | | | | | | VISIT / CHANGE HISTORY | | | | | |
|------------------------|------------|------|--------------|--------|------------|--------|------------|------------|--|------------------------|----|------|----|----|----------------------------|
| Permit Id | Issue Date | Type | Description | Amount | Insp Date | % Comp | Date Comp | Comments | | Date | Id | Type | Is | Cd | Purpost/Result |
| 201203548 | 06-14-2012 | OB | Out Building | | 12-02-2013 | 100 | 06-30-2014 | SHED 10X20 | | 05-11-2020 | WD | | | FR | Field Review |
| | | | | | | | | | | 10-06-2017 | MD | 22 | | 22 | Change of Address |
| | | | | | | | | | | 07-18-2017 | SR | 02 | | 14 | Cyclical Inspection |
| | | | | | | | | | | 03-25-2015 | AL | 22 | | 22 | Change of Address |
| | | | | | | | | | | 12-16-2013 | MW | 02 | | 02 | Bldg Permit Completed |
| | | | | | | | | | | 04-08-2002 | PT | 01 | | 00 | Meas/Listed-Interior Acces |

| LAND LINE VALUATION SECTION | | | | | | | | | | | | | | | | |
|-----------------------------|----------|----------------|------|----|------------|------------|------------------------|---------|------------|-------|-------|-----------|------------------|--------------------|------------|------------|
| B | Use Code | Description | Zone | LA | Land Units | Unit Price | Size Adj | AC Disc | Site Index | Cond. | Nbhd. | Nbhd. Adj | Notes | Location Adjustmen | Adj Unit P | Land Value |
| 1 | 1010 | Single Fam M-0 | RB | 4 | 0.670 | AC | 176,344.00 | 1.42670 | 1.0000 | 5 | 1.00 | 0113 | 6.300 | | 1.0000 | 1,585,015 |
| Total Card Land Units | | | | | 0.67 | AC | Parcel Total Land Area | | | | | 0.67 | Total Land Value | | | 1,062,000 |

| CONSTRUCTION DETAIL | | | CONSTRUCTION DETAIL (CONTINUED) | | |
|--------------------------------|------|----------------|---------------------------------|-----|-------------|
| Element | Cd | Description | Element | Cd | Description |
| Style | 04 | Cape Cod | | | |
| Model | 01 | Residential | | | |
| Grade: | C | Average | | | |
| Stories | 1.75 | 1 3/4 Stories | | | |
| Exterior Wall 1 | 14 | Wood Shingle | | | |
| Exterior Wall 2 | | | | | |
| CONDO DATA | | | | | |
| Parcel Id | | C | Owne | 0.0 | |
| Roof Structure | 03 | Gable/Hip | B | S | |
| Roof Cover | 03 | Asph/F Gls/Cmp | | | |
| Interior Wall 1 | 05 | Drywall | | | |
| Interior Wall 2 | | | | | |
| Interior Floor 1 | 12 | Hardwood | | | |
| Interior Floor 2 | | | | | |
| Heat Fuel | 03 | Gas | | | |
| Heat Type | 05 | Hot Water | | | |
| AC Type | 01 | None | | | |
| Bedrooms | 03 | 3 Bedrooms | | | |
| Full Baths | 1 | | | | |
| Half Baths | 1 | | | | |
| Extra Fixtures | | | | | |
| Total Rooms | 6 | 6 Rooms | | | |
| Bath Style | | | | | |
| Kitchen Style | | | | | |
| Occupancy | | | | | |
| Usrflid 105 | | | | | |
| Accessory Apt | | | | | |
| Foundation Alt | 02 | Conc. Block | | | |
| Rms Prts | | | | | |
| Bath Split | 11 | 1 Full-1 Half | | | |
| COST / MARKET VALUATION | | | | | |
| Building Value New | | 367,088 | | | |
| Year Built | | 1930 | | | |
| Effective Year Built | | 1979 | | | |
| Depreciation Code | | A | | | |
| Remodel Rating | | | | | |
| Year Remodeled | | | | | |
| Depreciation % | | 31 | | | |
| Functional Obsol | | 0 | | | |
| External Obsol | | 0 | | | |
| Trend Factor | | 1 | | | |
| Condition | | | | | |
| Condition % | | | | | |
| Percent Good | | 69 | | | |
| RCNLD | | 253,300 | | | |
| Dep % Ovr | | | | | |
| Dep Ovr Comment | | | | | |
| Misc Imp Ovr | | | | | |
| Misc Imp Ovr Comment | | | | | |
| Cost to Cure Ovr | | | | | |
| Cost to Cure Ovr Comment | | | | | |

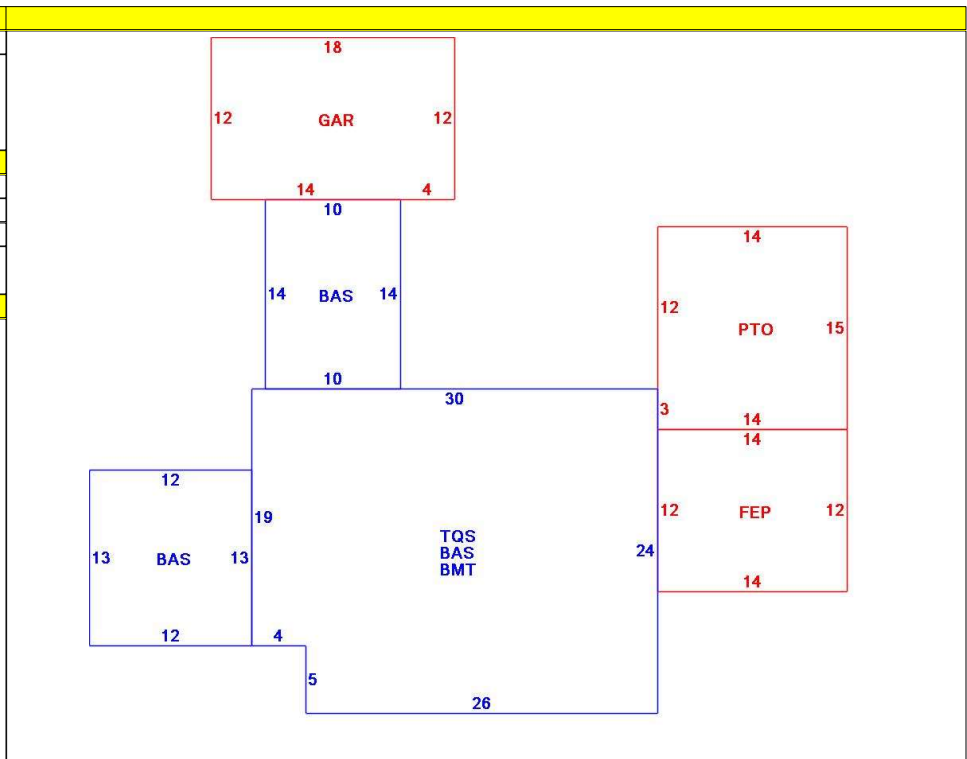

| OB - OUTBUILDING & YARD ITEMS(L) / XF - BUILDING EXTRA FEATURES(B) | | | | | | | | | | |
|--|-----------------|-----|-------|------------|--------|----------|------|-------|------------|-------------|
| Code | Description | L/B | Units | Unit Price | Yr Blt | Cond. Cd | % Gd | Grade | Grade Adj. | Appr. Value |
| FPL2 | Fireplace 1.5 s | B | 1 | 6000.00 | 1979 | | 69 | | 0.00 | 4,100 |
| PAT1 | Patio- Average | L | 210 | 5.89 | 1986 | | 67 | | 0.00 | 900 |
| FEP | Enclosed porc | B | 168 | 70.00 | 1979 | | 69 | | 0.00 | 7,800 |
| GAR | Attached Gara | B | 216 | 40.00 | 1979 | | 69 | | 0.00 | 7,200 |
| BMT | Basement-Unfi | B | 700 | 26.01 | 1979 | | 69 | | 0.00 | 14,500 |
| SHD2 | Shed w/Elec | L | 160 | 26.00 | 2012 | | 86 | | 0.00 | 3,600 |
| FPLG | Gas Fireplace- | B | 1 | 2500.00 | 1979 | | 69 | | 0.00 | 1,700 |

| BUILDING SUB-AREA SUMMARY SECTION | | | | | | |
|-----------------------------------|---------------------|-------------|------------|----------|-----------|----------------|
| Code | Description | Living Area | Floor Area | Eff Area | Unit Cost | Undeprec Value |
| BAS | First Floor | 996 | 996 | 996 | 252.99 | 251,978 |
| BMT | Basement Area | 0 | 700 | 0 | 0.00 | 0 |
| FEP | Enclosed Porch | 0 | 168 | 0 | 0.00 | 0 |
| GAR | Attached Garage | 0 | 216 | 0 | 0.00 | 0 |
| PTO | Patio | 0 | 210 | 0 | 0.00 | 0 |
| TQS | Three Quarter Story | 455 | 700 | 455 | 164.44 | 115,110 |
| Ttl Gross Liv / Lease Area | | 1,451 | 2,990 | 1,451 | | 367,088 |

