

| CURRENT OWNER           |  |  | TOPO    | UTILITIES    | STRT / ROAD             | LOCATION        | CURRENT ASSESSMENT |       |          |          |                                 |
|-------------------------|--|--|---------|--------------|-------------------------|-----------------|--------------------|-------|----------|----------|---------------------------------|
| COOK, W BRIAR           |  |  | 1 Level | 1 All Public | 1 Paved                 | 1 Lake/Pond Vie | Description        | Code  | Assessed | Assessed | 801<br>FY2024<br>BARNSTABLE, MA |
| 42 MARSH LANE           |  |  |         |              |                         |                 | RESIDENTL          | 1010  | 585,800  | 585,800  |                                 |
| HYANNIS MA 02601        |  |  |         |              |                         |                 | RES LAND           | 1010  | 296,900  | 296,900  |                                 |
| SUPPLEMENTAL DATA       |  |  |         |              |                         |                 |                    |       |          |          |                                 |
| Alt Prcl ID             |  |  |         |              | Plan Ref.               |                 |                    |       |          |          |                                 |
| Split Zonin             |  |  |         |              | Land Ct# 17595-I, L & P |                 |                    |       |          |          |                                 |
| BID Parcel              |  |  |         |              | #SR                     |                 |                    |       |          |          |                                 |
| ResExpt Q YES:          |  |  |         |              | Life Estate             |                 |                    |       |          |          |                                 |
| #DL 1 LOTS 14, 24 & 61  |  |  |         |              | PP STATU                |                 |                    |       |          |          |                                 |
| #DL 2                   |  |  |         |              |                         |                 |                    |       |          |          |                                 |
| GIS ID F_988480_2696495 |  |  |         |              | Assoc Pid#              |                 |                    |       |          |          |                                 |
|                         |  |  |         |              |                         |                 |                    | Total | 882,700  | 882,700  |                                 |

**VISION**

| RECORD OF OWNERSHIP       |  |  | BK-VOL/PAGE | SALE DATE | Q/U        | V/I | SALE PRIC | VC      | PREVIOUS ASSESSMENTS (HISTORY) |         |      |          |         |       |          |
|---------------------------|--|--|-------------|-----------|------------|-----|-----------|---------|--------------------------------|---------|------|----------|---------|-------|----------|
| COOK, W BRIAR             |  |  | D126911     | 0         | 05-14-2015 | U   | I         | 0       | 1A                             | Year    | Code | Assessed | Year    | Code  | Assessed |
| COOK, W BRIAR & SHIRLEY A |  |  | C147280     | 0         | 01-23-1998 | Q   | I         | 175,000 | 00                             | 2023    | 1010 | 500,400  | 2022    | 1010  | 417,000  |
| CHAMBERS, JAN R           |  |  | C123071     | 0         | 04-15-1991 | U   | I         | 100     | 1                              |         | 1010 | 293,800  |         | 1010  | 189,600  |
| CHAMBERS, ROGER A & JAN R |  |  | C72624      | 0         | 12-05-1977 | U   |           | 0       |                                |         |      |          |         | 1010  | 14,000   |
|                           |  |  |             |           |            |     |           | Total   |                                | 794,200 |      | Total    | 606,600 | Total | 550,200  |

| EXEMPTIONS |      |                       |        | OTHER ASSESSMENTS |             |        |        |
|------------|------|-----------------------|--------|-------------------|-------------|--------|--------|
| Year       | Code | Description           | Amount | Code              | Description | Number | Amount |
| 2022       | 5C   | RESIDENTIAL EXEMPTION | 0.00   |                   |             |        |        |
| Total      |      |                       | 0.00   |                   |             |        |        |

This signature acknowledges a visit by a Data Collector or Assessor

| ASSESSING NEIGHBORHOOD |           |   |               |
|------------------------|-----------|---|---------------|
| Nbhd                   | Nbhd Name | B | Tracing       |
| 0108                   |           |   | Batch<br>HYAN |

| APPRAISED VALUE SUMMARY       |         |
|-------------------------------|---------|
| Appraised Bldg. Value (Card)  | 527,800 |
| Appraised Xf (B) Value (Bldg) | 44,000  |
| Appraised Ob (B) Value (Bldg) | 14,000  |
| Appraised Land Value (Bldg)   | 296,900 |
| Special Land Value            | 0       |
| Total Appraised Parcel Value  | 882,700 |
| Valuation Method              | C       |
| Total Appraised Parcel Value  | 882,700 |

| NOTES |  |  |  |  |  |  |  |  |  |  |  |
|-------|--|--|--|--|--|--|--|--|--|--|--|
|       |  |  |  |  |  |  |  |  |  |  |  |

| BUILDING PERMIT RECORD |            |      |                |        |            |        |            |                                  | VISIT / CHANGE HISTORY |    |      |    |    |                            |
|------------------------|------------|------|----------------|--------|------------|--------|------------|----------------------------------|------------------------|----|------|----|----|----------------------------|
| Permit Id              | Issue Date | Type | Description    | Amount | Insp Date  | % Comp | Date Comp  | Comments                         | Date                   | Id | Type | Is | Cd | Purpost/Result             |
| 16-759                 | 04-11-2016 | 839  | Solar Panel-Re | 5,100  | 08-29-2016 | 100    | 06-30-2017 | install solar panels on existing | 02-18-2022             | LH | 03   |    | 16 | In Office Review           |
| 201508677              | 12-23-2015 | IN   | Insulation     | 750    | 06-30-2016 | 100    | 06-30-2016 | WEATHERIZATION                   | 05-11-2020             | WD |      |    | FR | Field Review               |
| 29329                  | 03-10-1998 | AD   | Addition       | 27,000 | 06-01-1999 | 100    | 12-31-1999 |                                  | 04-07-2017             | JR | 01   |    | 02 | Bldg Permit Completed      |
| 29028                  | 02-20-1998 | RA   | Remodel-Additi | 41,000 | 06-01-1999 | 100    | 12-31-1999 |                                  | 03-28-2002             | PT | 01   |    | 00 | Meas/Listed-Interior Acces |
|                        |            |      |                |        |            |        |            |                                  | 06-03-1998             | LK | 01   |    | 00 | Meas/Listed-Interior Acces |

| LAND LINE VALUATION SECTION |          |                |      |    |            |            |                        |         |            |       |       |           |                  |                    |            |            |         |
|-----------------------------|----------|----------------|------|----|------------|------------|------------------------|---------|------------|-------|-------|-----------|------------------|--------------------|------------|------------|---------|
| B                           | Use Code | Description    | Zone | LA | Land Units | Unit Price | Size Adj               | AC Disc | Site Index | Cond. | Nbhd. | Nbhd. Adj | Notes            | Location Adjustmen | Adj Unit P | Land Value |         |
| 1                           | 1010     | Single Fam M-0 | RB   | 4  | 0.760      | AC         | 176,344.00             | 1.28647 | 1.0000     | 5     | 1.00  | 0108      | 1.700            |                    | 1.0000     | 385,664.3  | 293,100 |
| 1                           | 1010     | Single Fam M-0 | RB   | 4  | 1.610      | AC         | 2,375.00               | 1.00000 | 1.0000     | 0     | 1.00  | WTLD      | 1.000            | WETLAND            | 1.0000     | 2,375      | 3,800   |
| Total Card Land Units       |          |                |      |    | 2.37       | AC         | Parcel Total Land Area |         |            |       |       | 2.37      | Total Land Value |                    |            |            | 296,900 |

| CONSTRUCTION DETAIL |    |                | CONSTRUCTION DETAIL (CONTINUED)      |    |             |
|---------------------|----|----------------|--------------------------------------|----|-------------|
| Element             | Cd | Description    | Element                              | Cd | Description |
| Style               | 06 | Conventional   |                                      |    |             |
| Model               | 01 | Residential    |                                      |    |             |
| Grade:              | C+ | Average Plus   |                                      |    |             |
| Stories             | 2  | 2 Stories      |                                      |    |             |
| Exterior Wall 1     | 14 | Wood Shingle   |                                      |    |             |
| Exterior Wall 2     |    |                |                                      |    |             |
| RooF Structure      | 03 | Gable/Hip      |                                      |    |             |
| RooF Cover          | 03 | Asph/F Gls/Cmp |                                      |    |             |
| Interior Wall 1     | 05 | Drywall        |                                      |    |             |
| Interior Wall 2     |    |                |                                      |    |             |
| Interior Floor 1    | 12 | Hardwood       |                                      |    |             |
| Interior Floor 2    | 14 | Carpet         |                                      |    |             |
| Heat Fuel           | 03 | Gas            |                                      |    |             |
| Heat Type           | 05 | Hot Water      |                                      |    |             |
| AC Type             | 03 | Central        |                                      |    |             |
| Bedrooms            | 04 | 4 Bedrooms     |                                      |    |             |
| Full Baths          | 2  |                |                                      |    |             |
| Half Baths          | 0  |                |                                      |    |             |
| Extra Fixtures      |    |                |                                      |    |             |
| Total Rooms         | 6  | 6 Rooms        |                                      |    |             |
| Bath Style          |    |                |                                      |    |             |
| Kitchen Style       |    |                |                                      |    |             |
| Occupancy           |    |                |                                      |    |             |
| Usrflid 105         |    |                |                                      |    |             |
| Accessory Apt       |    |                |                                      |    |             |
| Foundation Alt      | 08 | Mixed          |                                      |    |             |
| Rms Prts            |    |                |                                      |    |             |
| Bath Split          | 20 | 2 Full-0 Half  |                                      |    |             |
|                     |    |                | <b>CONDO DATA</b>                    |    |             |
|                     |    |                | Parcel Id                            | C  | Owne 0.0    |
|                     |    |                | Adjust Type Code Description Factor% |    |             |
|                     |    |                | Condo Flr                            |    |             |
|                     |    |                | Condo Unit                           |    |             |
|                     |    |                | <b>COST / MARKET VALUATION</b>       |    |             |
|                     |    |                | Building Value New                   |    | 685,423     |
|                     |    |                | Year Built                           |    | 1939        |
|                     |    |                | Effective Year Built                 |    | 1989        |
|                     |    |                | Depreciation Code                    |    | VG          |
|                     |    |                | Remodel Rating                       |    |             |
|                     |    |                | Year Remodeled                       |    |             |
|                     |    |                | Depreciation %                       |    | 23          |
|                     |    |                | Functional Obsol                     |    | 0           |
|                     |    |                | External Obsol                       |    | 0           |
|                     |    |                | Trend Factor                         |    | 1           |
|                     |    |                | Condition                            |    |             |
|                     |    |                | Condition %                          |    |             |
|                     |    |                | Percent Good                         |    | 77          |
|                     |    |                | RCNLD                                |    | 527,800     |
|                     |    |                | Dep % Ovr                            |    |             |
|                     |    |                | Dep Ovr Comment                      |    |             |
|                     |    |                | Misc Imp Ovr                         |    |             |
|                     |    |                | Misc Imp Ovr Comment                 |    |             |
|                     |    |                | Cost to Cure Ovr                     |    |             |
|                     |    |                | Cost to Cure Ovr Comment             |    |             |

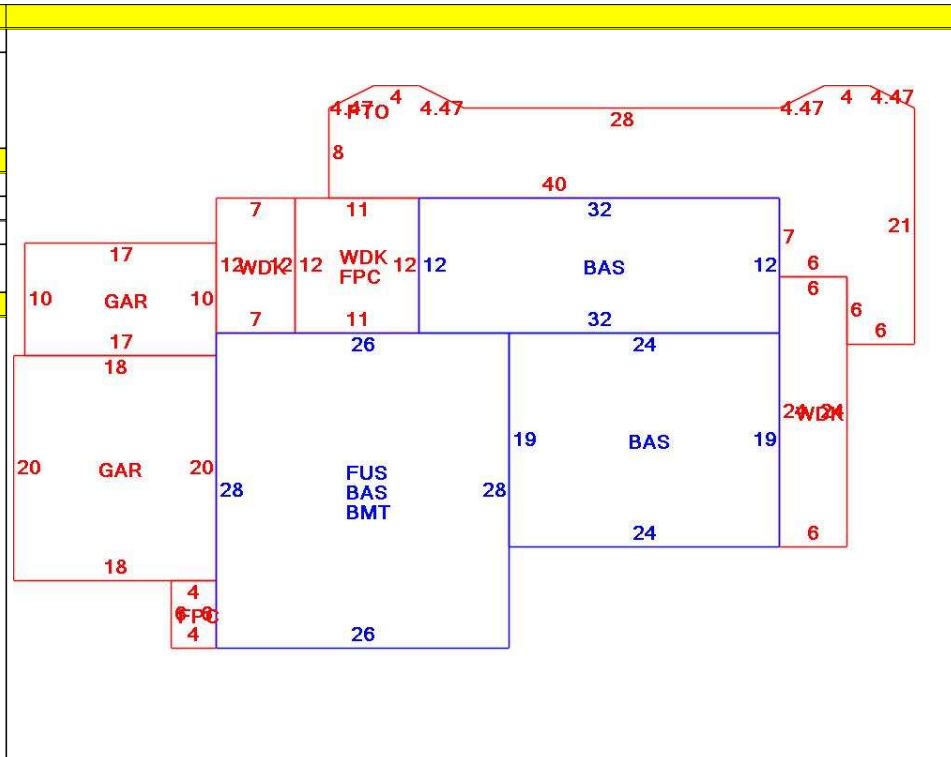

| OB - OUTBUILDING & YARD ITEMS(L) / XF - BUILDING EXTRA FEATURES(B) |                 |     |       |            |        |          |      |       |            |             |
|--|-----------------|-----|-------|------------|--------|----------|------|-------|------------|-------------|
| Code   | Description     | L/B | Units | Unit Price | Yr Blt | Cond. Cd | % Gd | Grade | Grade Adj. | Appr. Value |
| FPL2   | Fireplace 1.5 s | B   | 1     | 6000.00    | 1989   |          | 77   |       | 0.00       | 4,600       |
| FPO  | Ext FP Openin   | B   | 2     | 2000.00    | 1989   |          | 77   |       | 0.00       | 3,100       |
| WDC  | Wood Decking    | L   | 360   | 20.00      | 2001   |          | 64   |       | 0.00       | 4,500       |
| PAT1   | Patio- Average  | L   | 568   | 5.89       | 2001   |          | 82   |       | 0.00       | 2,600       |
| FOPC   | Open Prch-roo   | B   | 156   | 55.00      | 1989   |          | 77   |       | 0.00       | 4,800       |
| GAR  | Attached Gara   | B   | 530   | 40.00      | 1989   |          | 77   |       | 0.00       | 14,900      |
| BMT  | Basement-Unfi   | B   | 728   | 26.01      | 1989   |          | 77   |       | 0.00       | 16,600      |
| SOL1   | Solar PV Pane   | B   | 8     | 860.00     | 1989   |          | 0    |       | 0.00       | 0           |
| GEN  | Emergency Ge    | L   | 1     | 5550.00    | 2014   |          | 90   |       | 0.00       | 5,000       |
| SHED   | Shed            | L   | 120   | 18.00      | 2014   |          | 90   |       | 0.00       | 1,900       |

| BUILDING SUB-AREA SUMMARY SECTION |                        |             |            |          |           |                |
|-----------------------------------|------------------------|-------------|------------|----------|-----------|----------------|
| Code                              | Description            | Living Area | Floor Area | Eff Area | Unit Cost | Undeprec Value |
| BAS                               | First Floor            | 1,568       | 1,568      | 1,568    | 298.53    | 468,093        |
| BMT                               | Basement Area          | 0           | 728        | 0        | 0.00      | 0              |
| FPC                               | Open Porch Conc. Floor | 0           | 156        | 0        | 0.00      | 0              |
| FUS                               | Upper Story            | 728         | 728        | 728      | 298.53    | 217,329        |
| GAR                               | Attached Garage        | 0           | 530        | 0        | 0.00      | 0              |
| PTO                               | Patio                  | 0           | 568        | 0        | 0.00      | 0              |
| WDK                               | Wood Deck              | 0           | 360        | 0        | 0.00      | 0              |
| Ttl Gross Liv / Lease Area        |                        | 2,296       | 4,638      | 2,296    |           | 685,422        |

