

CURRENT OWNER		TOPO	UTILITIES	STRT / ROAD	LOCATION	CURRENT ASSESSMENT				801 FY2024 BARNSTABLE, MA VISION
DONOVAN, JACQUELINE & MATTHE JM DONOVAN FAM REV TRUST 10 SHADY LANE		1 Level	1 All Public	1 Paved		Description	Code	Assessed	Assessed	
WALPOLE MA 02081					RESIDNTL	1010	600,400	600,400		
					RES LAND	1010	322,700	322,700		
SUPPLEMENTAL DATA										
Alt Prcl ID Split Zonin BID Parcel ResExpt Q #DL 1 PARCEL 1 #DL 2 GIS ID F_989569_2698002				Plan Ref. 220/125 Land Ct# #SR Life Estate PP STATU Assoc Pid#		Total				923,100

RECORD OF OWNERSHIP		BK-VOL/PAGE	SALE DATE	Q/U	V/I	SALE PRIC	VC	PREVIOUS ASSESSMENTS (HISTORY)					
DONOVAN, JACQUELINE & MATTHEW T	35219	047	06-29-2022	U	I	1	1F	Year	Code	Assessed	Year	Code	Assessed
DONOVAN, JACQUELINE & MATTHEW	34535	297	10-01-2021	U	I	940,000	1V	2023	1010	529,600	2022	1010	446,300
GOLDSTEIN-DAVIS, SANDRA L TR	22919	0307	05-19-2008	Q	I	580,800	00		1010	300,000	2021	1010	227,200
SEGALL, NANCY LOUISE & RYAN, ERIN	19796	0175	05-05-2005	U	I	1	1					1010	4,700
SEGALL, NANCY & RYAN E	18302	0102	03-10-2004	U	I	370,000	1	Total		829,600	Total		653,700
								Total		608,800	Total		608,800

EXEMPTIONS			OTHER ASSESSMENTS				This signature acknowledges a visit by a Data Collector or Assessor						
Year	Code	Description	Amount	Code	Description	Number	Amount	Comm Int					
		Total	0.00										

ASSESSING NEIGHBORHOOD				APPRAISED VALUE SUMMARY			
Nbhd	Nbhd Name	B	Tracing	Batch			
0109				HYAN	Appraised Bldg. Value (Card)	559,400	
					Appraised Xf (B) Value (Bldg)	36,300	
					Appraised Ob (B) Value (Bldg)	4,700	
					Appraised Land Value (Bldg)	322,700	
					Special Land Value	0	
					Total Appraised Parcel Value	923,100	
					Valuation Method	C	
					Total Appraised Parcel Value	923,100	

BUILDING PERMIT RECORD								VISIT / CHANGE HISTORY						
Permit Id	Issue Date	Type	Description	Amount	Insp Date	% Comp	Date Comp	Comments	Date	Id	Type	Is	Cd	Purpost/Result
200803012	06-11-2008	RW	Repair Work	0	10-27-2008	100	06-30-2009		05-11-2020	WD			FR	Field Review
79470	09-23-2004	AD	Addition	163,104	02-21-2006	100	01-01-2006		03-10-2017	JR	03		03	Cycl Insp Comp
									03-30-2009	JG	03		16	In Office Review
									10-27-2008	MK	02		02	Bldg Permit Completed
									02-21-2006	PT	02		01	Meas/Est
									01-23-2006	JG	03		50	CO Issued
									11-17-2005	MF	01		00	Meas/Listed-Interior Acces

LAND LINE VALUATION SECTION																	
B	Use Code	Description	Zone	LA	Land Units	Unit Price	Size Adj	AC Disc	Site Index	Cond.	Nbhd.	Nbhd. Adj	Notes	Location Adjustmen	Adj Unit P	Land Value	
1	1010	Single Fam M-0	RB	4	0.230	AC	176,344.00	3.61599	1.0000	5	1.00	0109	2.200		1.0000	1,402,851	322,700
Total Card Land Units					0.23	AC	Parcel Total Land Area					0.23	Total Land Value			322,700	

CONSTRUCTION DETAIL			CONSTRUCTION DETAIL (CONTINUED)		
Element	Cd	Description	Element	Cd	Description
Style	04	Cape Cod			
Model	01	Residential			
Grade:	C+	Average Plus			
Stories	2	2 Stories			
Exterior Wall 1	14	Wood Shingle			
Exterior Wall 2					
RooF Structure	03	Gable/Hip			
RooF Cover	03	Asph/F Gls/Cmp			
Interior Wall 1	05	Drywall			
Interior Wall 2	03	Plastered			
Interior Floor 1	12	Hardwood			
Interior Floor 2					
Heat Fuel	03	Gas			
Heat Type	05	Hot Water			
AC Type	03	Central			
Bedrooms	04	4 Bedrooms			
Full Baths	3				
Half Baths	0				
Extra Fixtures					
Total Rooms	8				
Bath Style					
Kitchen Style					
Occupancy					
UsrflD 105					
Accessory Apt	Y	Apt here			
Foundation Alt	08	Mixed			
Rms Prts					
Bath Split	30	3 Full-0 Half			
			CONDO DATA		
			Parcel Id	C	Owne 0.0
			Adjust Type Code Description Factor%		
			Condo Flr		
			Condo Unit		
			COST / MARKET VALUATION		
			Building Value New		726,511
			Year Built		1948
			Effective Year Built		1990
			Depreciation Code		VG
			Remodel Rating		
			Year Remodeled		
			Depreciation %		23
			Functional Obsol		0
			External Obsol		0
			Trend Factor		1
			Condition		
			Condition %		
			Percent Good		77
			RCNLD		559,400
			Dep % Ovr		
			Dep Ovr Comment		
			Misc Imp Ovr		
			Misc Imp Ovr Comment		
			Cost to Cure Ovr		
			Cost to Cure Ovr Comment		

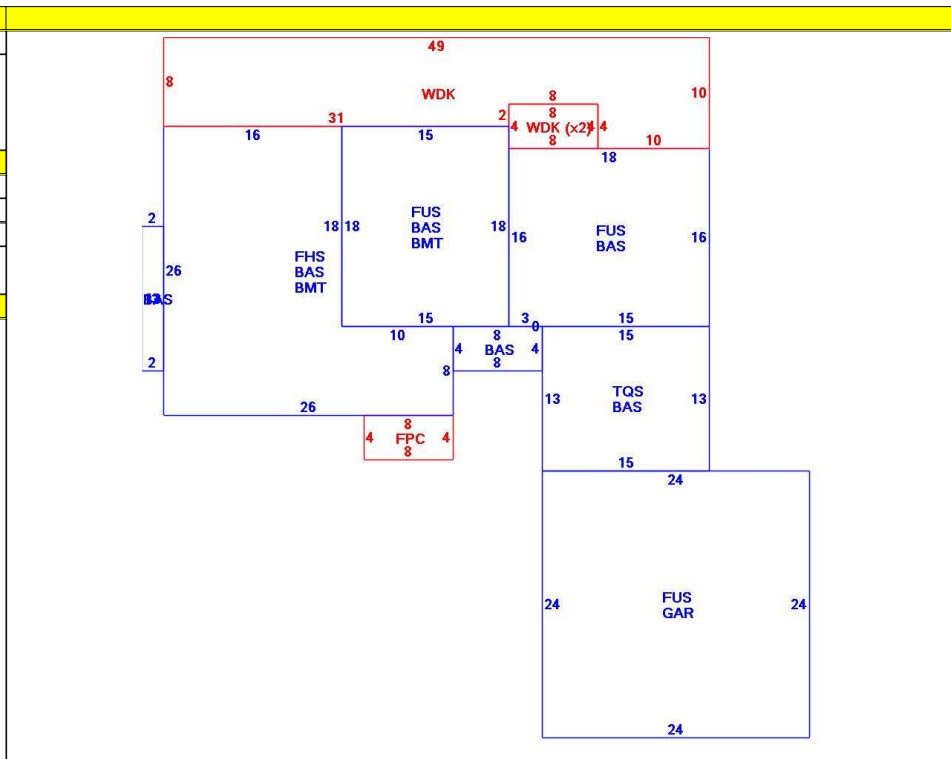

OB - OUTBUILDING & YARD ITEMS(L) / XF - BUILDING EXTRA FEATURES(B)										
Code	Description	L/B	Units	Unit Price	Yr Blt	Cond. Cd	% Gd	Grade	Grade Adj.	Appr. Value
FPLG	Gas Fireplace	B	1	2500.00	1992		77		0.00	1,900
WDC	Wood Decking	L	460	20.00	1996		54		0.00	4,700
FOPC	Open Prch-roo	B	32	55.00	1992		77		0.00	1,600
GAR	Attached Gara	B	576	40.00	1992		77		0.00	15,700
BMT	Basement-Unfi	B	766	26.01	1992		77		0.00	17,100

BUILDING SUB-AREA SUMMARY SECTION						
Code	Description	Living Area	Floor Area	Eff Area	Unit Cost	Undeprec Value
BAS	First Floor	1,307	1,307	1,307	257.99	337,198
BMT	Basement Area	0	766	0	0.00	0
FHS	Half Story	248	496	248	129.00	63,983
FPC	Open Porch Conc. Floor	0	32	0	0.00	0
FUS	Upper Story	1,134	1,134	1,134	257.99	292,565
GAR	Attached Garage	0	576	0	0.00	0
TQS	Three Quarter Story	127	195	127	168.03	32,765
WDK	Wood Deck	0	460	0	0.00	0
Ttl Gross Liv / Lease Area		2,816	4,966	2,816		726,511

