

CURRENT OWNER		TOPO	UTILITIES	STRT / ROAD	LOCATION	CURRENT ASSESSMENT				801 FY2024 BARNSTABLE, MA  <b>VISION</b>
CONSTANTINE, CONNIE S TR CONNIE S CONSTANTINE NOMINEE 87 BAY SHORE RD		1 Level	1 All Public	1 Paved	1 Marginal View	Description	Code	Assessed	Assessed	
HYANNIS MA 02601		SUPPLEMENTAL DATA			RESIDNTL	1010	537,400	537,400		
					RES LAND	1010	787,500	787,500		
		Alt Prcl ID Split Zonin BID Parcel ResExpt Q #DL 1 LOT105 #DL 2 GIS ID F_990228_2698355			Plan Ref. Land Ct# 7615-B #SR Life Estate PP STATU Assoc Pid#	Total		1,324,900	1,324,900	

RECORD OF OWNERSHIP		BK-VOL/PAGE	SALE DATE	Q/U	V/I	SALE PRIC	VC	PREVIOUS ASSESSMENTS (HISTORY)							
CONSTANTINE, CONNIE S TR		C149938	0	08-31-1998	U	I	1	1A	Year	Code	Assessed	Year	Code	Assessed	
CONSTANTINE, CHARLES A & CONNIE S		C138972	0	11-15-1995	U	I	1	A	2023	1010	452,900	2022	1010	368,200	
CONSTANTINE, CHARLES A		C138971	0	11-15-1995	U	I	1	A		1010	650,900		1010	424,300	
CONSTANTINE, ANTHONY		C24061	0	10-08-1959	U		0	A					1010	6,900	
		Total								1,103,800	Total		792,500	Total 720,400	

EXEMPTIONS			OTHER ASSESSMENTS					
Year	Code	Description	Amount	Code	Description	Number	Amount	Comm Int
Total		0.00						

ASSESSING NEIGHBORHOOD				
Nbhd	Nbhd Name	B	Tracing	Batch
0112				HYAN

  

APPRAISED VALUE SUMMARY	
Appraised Bldg. Value (Card)	522,100
Appraised Xf (B) Value (Bldg)	8,400
Appraised Ob (B) Value (Bldg)	6,900
Appraised Land Value (Bldg)	787,500
Special Land Value	0
Total Appraised Parcel Value	1,324,900
Valuation Method	C
Total Appraised Parcel Value	1,324,900

BUILDING PERMIT RECORD								VISIT / CHANGE HISTORY						
Permit Id	Issue Date	Type	Description	Amount	Insp Date	% Comp	Date Comp	Comments	Date	Id	Type	Is	Cd	Purpost/Result
B33514	02-01-1990	AD	Addition	75,000	01-15-1992	100		HY 2ND FL	11-16-2023	AG	03		16	In Office Review
									07-31-2023	TR	03		16	In Office Review
									05-12-2020	WD			FR	Field Review
									03-22-2017	JR	01		03	Cycl Insp Comp

LAND LINE VALUATION SECTION																	
B	Use Code	Description	Zone	LA	Land Units	Unit Price	Size Adj	AC Disc	Site Index	Cond.	Nbhd.	Nbhd. Adj	Notes	Location Adjustmen	Adj Unit P	Land Value	
1	1010	Single Fam M-0	RB	4	0.200	AC	176,344.00	4.05999	1.0000	5	1.00	0112	5.500		1.0000	3,937,743	787,500
Total Card Land Units					0.20	AC	Parcel Total Land Area					0.20	Total Land Value			787,500	

CONSTRUCTION DETAIL			CONSTRUCTION DETAIL (CONTINUED)		
Element	Cd	Description	Element	Cd	Description
Style	03	Colonial			
Model	01	Residential			
Grade:	C+	Average Plus			
Stories	2	2 Stories			
Exterior Wall 1	25	Vinyl Siding			
Exterior Wall 2					
RooF Structure	03	Gable/Hip			
RooF Cover	03	Asph/F Gls/Cmp			
Interior Wall 1	05	Drywall			
Interior Wall 2					
Interior Floor 1	14	Carpet			
Interior Floor 2	12	Hardwood			
Heat Fuel	03	Gas			
Heat Type	05	Hot Water			
AC Type	01	None			
Bedrooms	04	4 Bedrooms			
Full Baths	2				
Half Baths	1				
Extra Fixtures					
Total Rooms	7	7 Rooms			
Bath Style					
Kitchen Style					
Occupancy					
Usrflid 105					
Accessory Apt					
Foundation Alt	09	Blk/Pour Ftgs			
Rms Prts					
Bath Split	21	2 Full-1 Half			
			<b>CONDO DATA</b>		
			Parcel Id	C	Owne 0.0
			Adjust Type	Code	Description Factor%
			Condo Flr		
			Condo Unit		
			<b>COST / MARKET VALUATION</b>		
			Building Value New		705,586
			Year Built		1950
			Effective Year Built		1986
			Depreciation Code		G
			Remodel Rating		
			Year Remodeled		
			Depreciation %		26
			Functional Obsol		0
			External Obsol		0
			Trend Factor		1
			Condition		
			Condition %		
			Percent Good		74
			RCNLD		522,100
			Dep % Ovr		
			Dep Ovr Comment		
			Misc Imp Ovr		
			Misc Imp Ovr Comment		
			Cost to Cure Ovr		
			Cost to Cure Ovr Comment		

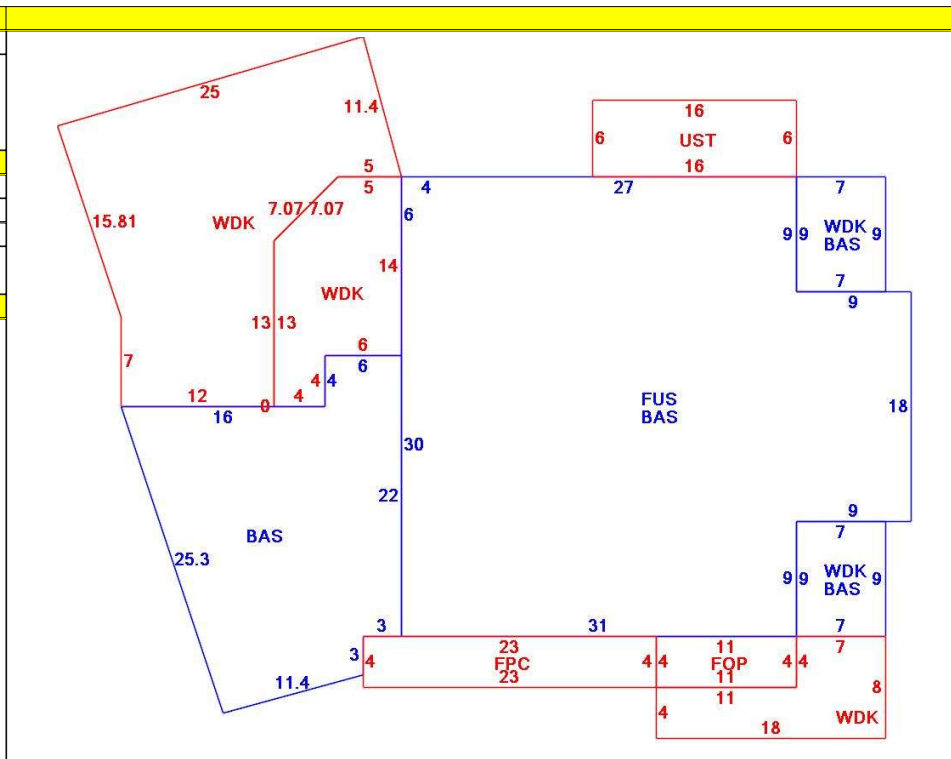

OB - OUTBUILDING & YARD ITEMS(L) / XF - BUILDING EXTRA FEATURES(B)										
Code	Description	L/B	Units	Unit Price	Yr Blt	Cond. Cd	% Gd	Grade	Grade Adj.	Appr. Value
FPLG	Gas Fireplace-	B	1	2500.00	1988		74		0.00	1,900
WDC	Wood Decking	L	370	20.00	1990		42		0.00	3,000
FOP	Open Porch-ro	B	44	55.00	1988		74		0.00	2,300
UST	Utility Storage-	B	96	17.11	1988		74		0.00	1,000
WDC	Wood Deck w/	L	442	18.00	1990		42		0.00	3,200
SHED	Shed	L	96	18.00	1990		42		0.00	700
FOPC	Open Prch-roo	B	92	55.00	1988		74		0.00	3,200

BUILDING SUB-AREA SUMMARY SECTION						
Code	Description	Living Area	Floor Area	Eff Area	Unit Cost	Undeprec Value
BAS	First Floor	1,826	1,826	1,826	227.32	415,077
FOP	Open Porch	0	44	0	0.00	0
FPC	Open Porch Conc. Floor	0	92	0	0.00	0
FUS	Upper Story	1,278	1,278	1,278	227.32	290,509
UST	Utility Enclosure	0	96	0	0.00	0
WDK	Wood Deck	0	813	0	0.00	0
Ttl Gross Liv / Lease Area		3,104	4,149	3,104		705,586

