

| CURRENT OWNER | | | TOPO | UTILITIES | STRT / ROAD | LOCATION | CURRENT ASSESSMENT | | | | 801 FY2024 BARNSTABLE, MA VISION | | | | |
|--|--|--|--|--------------|-------------|--|--------------------|------|----------|----------|--|----------------------|--------------|----------------------|----------------------|
| RO, CHARLES F JR & JACQUELINE A 4 RANDELL RD SAUGUS MA 01906 | | | 1 Level | 1 All Public | 1 Paved | 7 Waterfront | Description | Code | Assessed | Assessed | | RESIDNTL RES LAND | 1040 1040 | 732,600 1,935,800 | 732,600 1,935,800 |
| | | | SUPPLEMENTAL DATA | | | | | | Total | | | | | | |
| | | | Alt Prcl ID Split Zonin BID Parcel ResExpt Q #DL 1 LOT 91 & 92 #DL 2 GIS ID F_990817_2697949 | | | Plan Ref. Land Ct# 7615-B #SR Life Estate PP STATU Assoc Pid# | | | | | | | | | |
| | | | | | | | | | | | | | | | |

| RECORD OF OWNERSHIP | | BK-VOL/PAGE | SALE DATE | Q/U | V/I | SALE PRIC | VC | PREVIOUS ASSESSMENTS (HISTORY) | | | | | | | | |
|---------------------------------|---------|-------------|------------|------|------------|-----------|------|--------------------------------|------|-----------|----------|-----------|---------|----------|---------|-----------|
| Year | Code | Assessed | Year | Code | Assessed V | Year | Code | Assessed | Year | Code | Assessed | Year | Code | Assessed | | |
| RO, CHARLES F JR & JACQUELINE A | C183352 | 0 | 06-12-2007 | U | I | 1 | 1A | 2023 | 1040 | 658,400 | 2022 | 1040 | 570,800 | 2021 | 1040 | 355,000 |
| RO, CHARLES F JR & JACQUELINE | C141939 | 0 | 09-15-1996 | Q | I | 479,400 | U | | | | | | | | | |
| PARKER REALTY CORP | C61015 | 0 | 01-30-1974 | U | | 0 | | | | 1,759,900 | | | | 1040 | 964,700 | |
| | | | | | | | | | | | | | | 1040 | 143,000 | |
| Total | | | | | | | | 2,418,300 | | Total | | 1,561,500 | | Total | | 1,462,700 |

| EXEMPTIONS | | | OTHER ASSESSMENTS | | | | | APPRAISED VALUE SUMMARY | | | | | | |
|------------|------|-------------|-------------------|------|-------------|--------|--------|-------------------------|---|--|--|--|--|--|
| Year | Code | Description | Amount | Code | Description | Number | Amount | Comm Int | This signature acknowledges a visit by a Data Collector or Assessor | | | | | |
| | | | | | | | | | | | | | | |
| Total | | | 0.00 | | | | | | | | | | | |

| ASSESSING NEIGHBORHOOD | | | NOTES | | |
|------------------------|-----------|---|---------|-------|--|
| Nbhd | Nbhd Name | B | Tracing | Batch | |
| 0118 | | | | HYAN | |

| BUILDING PERMIT RECORD | | | | | | | | | | VISIT / CHANGE HISTORY | | | | | |
|------------------------|------------|------|----------------|--------|------------|--------|------------|-------------------------------|------------|------------------------|------|----|----|----------------------------|--|
| Permit Id | Issue Date | Type | Description | Amount | Insp Date | % Comp | Date Comp | Comments | Date | Id | Type | Is | Cd | Purpost/Result | |
| EXPR-23-11 | 08-29-2023 | 835 | Sid/Wind/Roof/ | 2,500 | | 100 | | Re-side gable wall | 08-21-2023 | LP | | | 16 | In Office Review | |
| EXPR-21-1 | 10-18-2021 | 835 | Sid/Wind/Roof/ | 7,000 | | 100 | | Remove and replace existing a | 05-12-2020 | WD | | | FR | Field Review | |
| 43927 | 02-01-2000 | DK | Dock | 22,500 | 06-28-2001 | 100 | 01-01-2001 | | 04-01-2014 | SR | 02 | | 03 | Cycl Insp Comp | |
| B29831 | 08-01-1986 | AD | Addition | 40,000 | 06-30-1987 | 100 | 06-30-1987 | HY ADD'N | 04-16-2002 | PT | 01 | | 00 | Meas/Listed-Interior Acces | |
| | | | | | | | | | 06-28-2001 | MF | 02 | | 02 | Bldg Permit Completed | |
| | | | | | | | | | 06-03-1998 | LK | | | | | |
| | | | | | | | | | 07-15-1988 | ML | 01 | | 00 | Meas/Listed-Interior Acces | |

| LAND LINE VALUATION SECTION | | | | | | | | | | | | | Notes | | | Location Adjustmen | | Adj Unit P | Land Value |
|-----------------------------|----------|-------------|------|----|------------|------------|------------------------|---------|------------|-------|-------|-----------|------------------|--|--|--------------------|--------|------------|------------|
| B | Use Code | Description | Zone | LA | Land Units | Unit Price | Size Adj | AC Disc | Site Index | Cond. | Nbhd. | Nbhd. Adj | | | | | | | |
| 1 | 1040 | Two Family | RB | 4 | 0.430 | AC | 176,344.00 | 2.04234 | 1.0000 | 5 | 1.00 | 0120 | 12.500 | | | | 1.0000 | 4,501,938 | 1,935,800 |
| Total Card Land Units | | | | | 0.43 | AC | Parcel Total Land Area | | | | | 0.43 | Total Land Value | | | | | 1,935,800 | |

| CONSTRUCTION DETAIL | | | CONSTRUCTION DETAIL (CONTINUED) | | |
|---------------------|------|----------------|---------------------------------|----|-------------|
| Element | Cd | Description | Element | Cd | Description |
| Style | 04 | Cape Cod | | | |
| Model | 01 | Residential | | | |
| Grade: | C+ | Average Plus | | | |
| Stories | 1.75 | 1 3/4 Stories | | | |
| Exterior Wall 1 | 14 | Wood Shingle | | | |
| Exterior Wall 2 | 11 | Clapboard | | | |
| RooF Structure | 03 | Gable/Hip | | | |
| RooF Cover | 03 | Asph/F Gls/Cmp | | | |
| Interior Wall 1 | 03 | Plastered | | | |
| Interior Wall 2 | | | | | |
| Interior Floor 1 | 14 | Carpet | | | |
| Interior Floor 2 | 12 | Hardwood | | | |
| Heat Fuel | 03 | Gas | | | |
| Heat Type | 05 | Hot Water | | | |
| AC Type | 03 | Central | | | |
| Bedrooms | 05 | 5 Bedrooms | | | |
| Full Baths | 3 | | | | |
| Half Baths | 0 | | | | |
| Extra Fixtures | | | | | |
| Total Rooms | 8 | 8 Rooms | | | |
| Bath Style | | | | | |
| Kitchen Style | | | | | |
| Occupancy | | | | | |
| UsrflD 105 | | | | | |
| Accessory Apt | | | | | |
| Foundation Alt | 09 | Blk/Pour Ftgs | | | |
| Rms Prts | | | | | |
| Bath Split | 30 | 3 Full-0 Half | | | |

| CONDO DATA | | | | |
|-------------|------|-------------|---------|----------|
| Parcel Id | | C | | Owne 0.0 |
| | | | B | S |
| Adjust Type | Code | Description | Factor% | |
| Condo Flr | | | | |
| Condo Unit | | | | |

| COST / MARKET VALUATION | |
|--------------------------|---------|
| Building Value New | 803,450 |
| Year Built | 1946 |
| Effective Year Built | 1984 |
| Depreciation Code | G |
| Remodel Rating | |
| Year Remodeled | |
| Depreciation % | 27 |
| Functional Obsol | 0 |
| External Obsol | 0 |
| Trend Factor | 1 |
| Condition | |
| Condition % | |
| Percent Good | 73 |
| RCNLD | 586,500 |
| Dep % Ovr | |
| Dep Ovr Comment | |
| Misc Imp Ovr | |
| Misc Imp Ovr Comment | |
| Cost to Cure Ovr | |
| Cost to Cure Ovr Comment | |

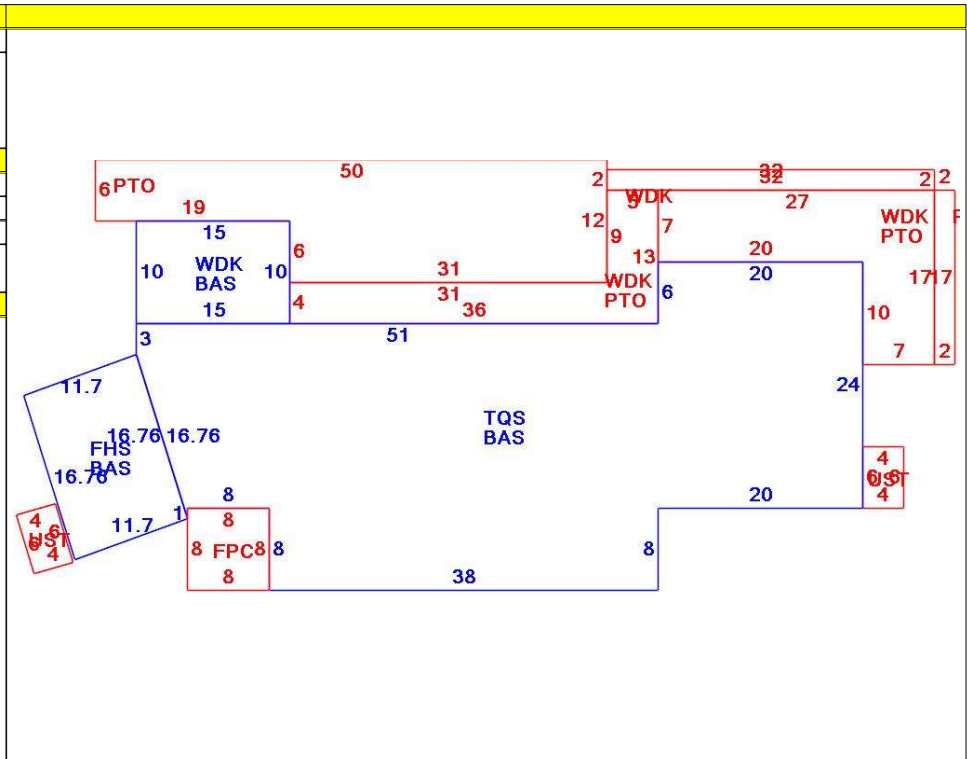

| OB - OUTBUILDING & YARD ITEMS(L) / XF - BUILDING EXTRA FEATURES(B) | | | | | | | | | | |
|--|------------------|-----|-------|------------|--------|----------|------|-------|------------|-------------|
| Code | Description | L/B | Units | Unit Price | Yr Blt | Cond. Cd | % Gd | Grade | Grade Adj. | Appr. Value |
| FGR2 | Garage- Avg- | L | 308 | 50.00 | 1946 | | 27 | 00 | 1.00 | 4,200 |
| DKHD | Dock-Heavy | L | 1 | 205000.0 | 2000 | | 62 | | 0.00 | 127,100 |
| WDC | Wood Decking | L | 662 | 20.00 | 1996 | | 54 | | 0.00 | 6,600 |
| PAT1 | Patio- Average | L | 968 | 5.89 | 1996 | | 77 | | 0.00 | 4,000 |
| FOPC | Open Prch-roo | B | 64 | 55.00 | 1986 | | 73 | | 0.00 | 2,500 |
| UST | Utility Storage- | B | 48 | 17.11 | 1986 | | 73 | | 0.00 | 600 |
| STRS | Stairs to Water | L | 14 | 122.52 | 2000 | | 62 | C | 1.00 | 1,100 |

| BUILDING SUB-AREA SUMMARY SECTION | | | | | | |
|-----------------------------------|------------------------|-------------|------------|----------|-----------|----------------|
| Code | Description | Living Area | Floor Area | Eff Area | Unit Cost | Undeprec Value |
| BAS | First Floor | 2,013 | 2,013 | 2,013 | 251.47 | 506,211 |
| FHS | Half Story | 98 | 196 | 98 | 125.74 | 24,644 |
| FPC | Open Porch Conc. Floor | 0 | 64 | 0 | 0.00 | 0 |
| PTO | Patio | 0 | 968 | 0 | 0.00 | 0 |
| TQS | Three Quarter Story | 1,084 | 1,667 | 1,084 | 163.52 | 272,595 |
| UST | Utility Enclosure | 0 | 48 | 0 | 0.00 | 0 |
| WDK | Wood Deck | 0 | 662 | 0 | 0.00 | 0 |
| Ttl Gross Liv / Lease Area | | 3,195 | 5,618 | 3,195 | | 803,450 |

