

CURRENT OWNER		TOPO	UTILITIES	STRT / ROAD	LOCATION	CURRENT ASSESSMENT				801 FY2024 BARNSTABLE, MA  <b>VISION</b>
ROCHE, LINDA		1 Level	1 All Public	1 Paved	1 Lake/Pond Vie	Description	Code	Assessed	Assessed	
17 SINGINGWOOD DRIVE						RESIDNTL	1010	286,900	286,900	
HAVERHILL MA 01830		<b>SUPPLEMENTAL DATA</b>				RES LAND	1010	206,900	206,900	
Alt Prcl ID		Split Zonin		Plan Ref.						
#DL 1 LOT 40		#DL 2		Land Ct# 17595-M						
GIS ID F_988260_2696836		Assoc Pid#								
						Total		493,800	493,800	

RECORD OF OWNERSHIP		BK-VOL/PAGE	SALE DATE	Q/U	V/I	SALE PRIC	VC	PREVIOUS ASSESSMENTS (HISTORY)						
ROCHE, LINDA		C181102	0	09-15-2006	U	I	0	1	Year	Code	Assessed	Year	Code	Assessed
ROCHE, LINDA		#D10441	0	09-15-2006	U	I	0	1	2023	1010	248,000	2022	1010	217,900
LODA, WILLIAM P		C47013	0	10-23-1969	Q		5,700	U		1010	188,100		1010	129,400
									Total		436,100	Total		347,300
									Total			Total		312,200

EXEMPTIONS			OTHER ASSESSMENTS				This signature acknowledges a visit by a Data Collector or Assessor					
Year	Code	Description	Amount	Code	Description	Number	Amount	Comm Int				
Total			0.00									

ASSESSING NEIGHBORHOOD				APPRAISED VALUE SUMMARY					
Nbhd	Nbhd Name	B	Tracing	Batch				Appraised Bldg. Value (Card)	244,500
0107				HYAN				Appraised Xf (B) Value (Bldg)	39,100
							Appraised Ob (B) Value (Bldg)	3,300	
							Appraised Land Value (Bldg)	206,900	
							Special Land Value	0	
							Total Appraised Parcel Value	493,800	
							Valuation Method	C	
							Total Appraised Parcel Value	493,800	

NOTES										VISIT / CHANGE HISTORY					
										Date	Id	Type	Is	Cd	Purpost/Result
										05-12-2020	WD			FR	Field Review
										08-28-2017	SR	02		03	Cycl Insp Comp
										04-11-2002	PT	01		00	Meas/Listed-Interior Acces
										06-15-1988	ML	01		00	Meas/Listed-Interior Acces

BUILDING PERMIT RECORD										LAND LINE VALUATION SECTION					
Permit Id	Issue Date	Type	Description	Amount	Insp Date	% Comp	Date Comp	Comments							

B	Use Code	Description	Zone	LA	Land Units	Unit Price	Size Adj	AC Disc	Site Index	Cond.	Nbhd.	Nbhd. Adj	Notes	Location Adjustmen	Adj Unit P	Land Value	
1	1010	Single Fam M-0	RB	4	0.240	AC	176,344.00	3.49265	1.0000	5	1.00	0107	1.400	PROXIMITY	1.0000	862,269.2	206,900

CONSTRUCTION DETAIL			CONSTRUCTION DETAIL (CONTINUED)		
Element	Cd	Description	Element	Cd	Description
Style	01	Ranch			
Model	01	Residential			
Grade:	C	Average			
Stories	1	1 Story			
Exterior Wall 1	14	Wood Shingle			
Exterior Wall 2	07	Asbest Shingle			
RooF Structure	03	Gable/Hip			
RooF Cover	03	Asph/F Gls/Cmp			
Interior Wall 1	05	Drywall			
Interior Wall 2					
Interior Floor 1	12	Hardwood			
Interior Floor 2					
Heat Fuel	03	Gas			
Heat Type	04	Hot Air			
AC Type	01	None			
Bedrooms	03	3 Bedrooms			
Full Baths	1				
Half Baths	0				
Extra Fixtures					
Total Rooms	6	6 Rooms			
Bath Style					
Kitchen Style					
Occupancy					
UsrflD 105					
Accessory Apt					
Foundation Alt	01	Poured Conc.			
Rms Prts					
Bath Split	10	1 Full-0 Half			

CONDO DATA			
Parcel Id	C	Ownr	0.0
Adjust Type	Code	Description	Factor%
Condo Flr			
Condo Unit			
COST / MARKET VALUATION			
Building Value New		313,485	
Year Built		1970	
Effective Year Built		1991	
Depreciation Code		A	
Remodel Rating			
Year Remodeled			
Depreciation %		22	
Functional Obsol		0	
External Obsol		0	
Trend Factor		1	
Condition			
Condition %			
Percent Good		78	
RCNLD		244,500	
Dep % Ovr			
Dep Ovr Comment			
Misc Imp Ovr			
Misc Imp Ovr Comment			
Cost to Cure Ovr			
Cost to Cure Ovr Comment			

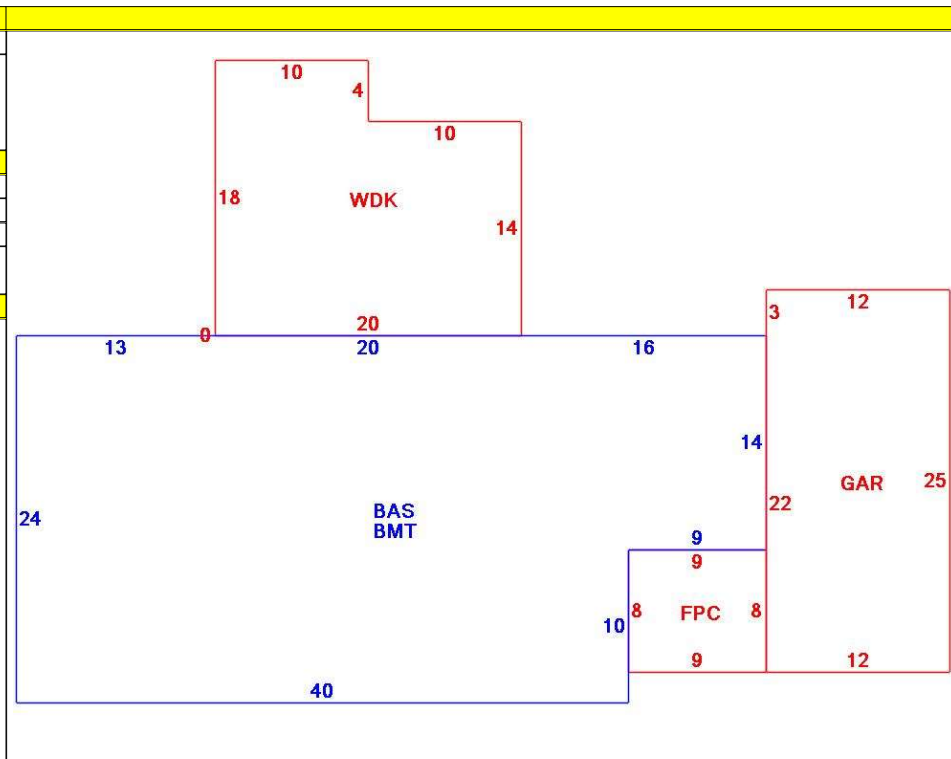

OB - OUTBUILDING & YARD ITEMS(L) / XF - BUILDING EXTRA FEATURES(B)										
Code	Description	L/B	Units	Unit Price	Yr Blt	Cond. Cd	% Gd	Grade	Grade Adj.	Appr. Value
FPL1	Fireplace 1 sto	B	1	5000.00	1993		78		0.00	3,900
WDC	Wood Decking	L	320	20.00	1995		52		0.00	3,300
FOPC	Open Prch-roo	B	72	55.00	1993		78		0.00	2,900
GAR	Attached Gara	B	300	40.00	1993		78		0.00	10,400
BMT	Basement-Unfi	B	1,086	26.01	1993		78		0.00	21,900

BUILDING SUB-AREA SUMMARY SECTION						
Code	Description	Living Area	Floor Area	Eff Area	Unit Cost	Undeprec Value
BAS	First Floor	1,086	1,086	1,086	288.66	313,485
BMT	Basement Area	0	1,086	0	0.00	0
FPC	Open Porch Conc. Floor	0	72	0	0.00	0
GAR	Attached Garage	0	300	0	0.00	0
WDK	Wood Deck	0	320	0	0.00	0
Ttl Gross Liv / Lease Area		1,086	2,864	1,086		313,485

