

CONSTRUCTION DETAIL			CONSTRUCTION DETAIL (CONTINUED)		
Element	Cd	Description	Element	Cd	Description
Style	23	Res Typ Com			
Model	01	Residential			
Grade:	B	Custom			
Stories	2	2 Stories			
Exterior Wall 1	11	Clapboard			
Exterior Wall 2					
Roof Structure	03	Gable/Hip			
Roof Cover	03	Asph/F Gls/Cmp			
Interior Wall 1	05	Drywall			
Interior Wall 2					
Interior Floor 1	14	Carpet			
Interior Floor 2					
Heat Fuel	03	Gas			
Heat Type	04	Hot Air			
AC Type	03	Central			
Bedrooms	00				
Full Baths	0				
Half Baths	2				
Extra Fixtures					
Total Rooms					
Bath Style					
Kitchen Style					
Occupancy	1				
Usrflid 105					
Accessory Apt					
Foundation Alt					
Rms Prts					
Bath Split					
CONDO DATA			COST / MARKET VALUATION		
Parcel Id		C	Ownr	0.0	
Adjust Type	Code	Description	Factor%		
Condo Flr					
Condo Unit					
Building Value New		406,111			
Year Built		1910			
Effective Year Built		1979			
Depreciation Code		A			
Remodel Rating					
Year Remodeled					
Depreciation %		31			
Functional Obsol		0			
External Obsol		0			
Trend Factor		1			
Condition					
Condition %					
Percent Good		69			
RCNLD		280,200			
Dep % Ovr					
Dep Ovr Comment					
Misc Imp Ovr					
Misc Imp Ovr Comment					
Cost to Cure Ovr					
Cost to Cure Ovr Comment					

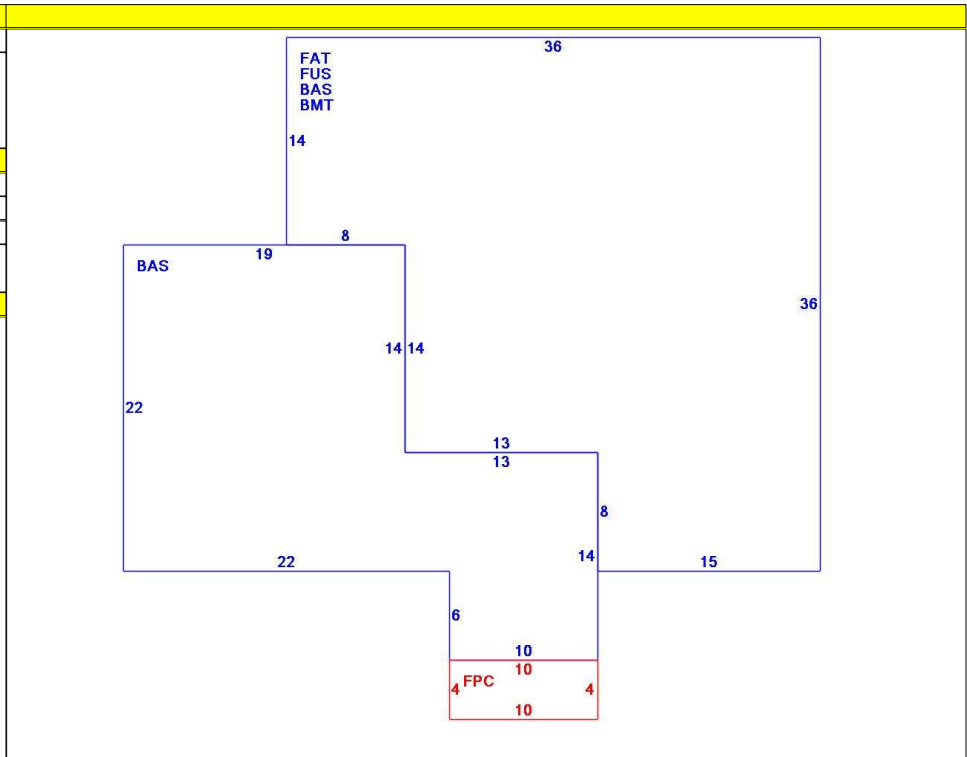

OB - OUTBUILDING & YARD ITEMS(L) / XF - BUILDING EXTRA FEATURES(B)										
Code	Description	L/B	Units	Unit Price	Yr Blt	Cond. Cd	% Gd	Grade	Grade Adj.	Appr. Value
PAV1	PAVING-ASP	L	4,500	3.00	1985		32		0.00	4,300
FOPC	Open Prch-roo	B	40	55.00	1979		69		0.00	1,700
BMT	Basement-Unfi	B	1,016	26.01	1979		69		0.00	18,500
GEN	Emergency Ge	L	1	5550.00	2012		86		0.00	4,800
SGN1	SIGN-1 SD W/	L	9	30.60	2017		96		0.00	300
SGNP	SIGN POST 6"	L	8	10.66	2017		96		0.00	100
PKKG	Gravel Pkg Lot	L	1,700	1.06	2017		96		0.00	1,700

BUILDING SUB-AREA SUMMARY SECTION							
Code	Description	Living Area	Floor Area	Eff Area	Unit Cost	Undeprec Value	
BAS	First Floor	1,598	1,598	1,598	146.44	234,012	
BMT	Basement Area	0	1,016	0	0.00	0	
FAT	Attic, Finished	152	1,016	152	21.91	22,259	
FPC	Open Porch Conc. Floor	0	40	0	0.00	0	
FUS	Upper Story	1,016	1,016	1,016	146.44	148,784	
Ttl Gross Liv / Lease Area		2,766	4,686	2,766		405,055	

