

CURRENT OWNER				TOPO	UTILITIES	STRT / ROAD	LOCATION	CURRENT ASSESSMENT				
WYMAN, MICHAEL P 66 CHANNEL POINT RD HYANNIS MA 02601				1	1	1	7	Description	Code	Assessed	Assessed	801 FY2024 BARNSTABLE, MA
							1	RESIDNTL	1010	540,200	540,200	
								RES LAND	1010	908,700	908,700	VISION
SUPPLEMENTAL DATA												
Alt Prcl ID Split Zonin BID Parcel ResExpt Q YES: #DL 1 LOT 165 #DL 2 GIS ID F_990093_2699288				Plan Ref. Land Ct# 7615-T #SR Life Estate MICHAEL P WYM PP STATU Assoc Pid#				Total		1,448,900	1,448,900	

RECORD OF OWNERSHIP				BK-VOL/PAGE	SALE DATE	Q/U	V/I	SALE PRIC	VC	PREVIOUS ASSESSMENTS (HISTORY)								
WYMAN, MICHAEL P				D946086	0	10-24-2003	U	I	0	1A	Year	Code	Assessed	Year	Code	Assessed		
WYMAN, MICHAEL P				C153744	0	06-28-1999	U	I	1	1A	2023	1010	484,400	2022	1010	437,300		
WYMAN, MICHAEL P & SILVER, ALEXIS				C145441	0	08-11-1997	U	I	0	1A		1010	826,100		1010	669,300		
WYMAN, MICHAEL P				C140889	0	05-15-1996	Q	I	318,000	U					1010	144,900		
MACRIDES, TASULA				C98274	0	08-15-1988	U	I	1	A	Total		1,310,500	Total		1,106,600	Total	1,098,700

EXEMPTIONS				OTHER ASSESSMENTS				
Year	Code	Description	Amount	Code	Description	Number	Amount	Comm Int
2010	5C	RESIDENTIAL EXEMPTION	0.00					
Total			0.00					

ASSESSING NEIGHBORHOOD				
Nbhd	Nbhd Name	B	Tracing	Batch
0115				HYAN

APPRAISED VALUE SUMMARY			
Appraised Bldg. Value (Card)			350,700
Appraised Xf (B) Value (Bldg)			44,600
Appraised Ob (B) Value (Bldg)			144,900
Appraised Land Value (Bldg)			908,700
Special Land Value			0
Total Appraised Parcel Value			1,448,900
Valuation Method			C
Total Appraised Parcel Value			1,448,900

BUILDING PERMIT RECORD									VISIT / CHANGE HISTORY					
Permit Id	Issue Date	Type	Description	Amount	Insp Date	% Comp	Date Comp	Comments	Date	Id	Type	Is	Cd	Purpost/Result
B33981	09-01-1990	WD	Wood Deck	1,200	04-15-1991	100	12-31-1991	HY DECK	06-28-2022	CK	02		03	Cycl Insp Comp
									05-12-2020	WD			FR	Field Review
									08-30-2017	SR	02		03	Cycl Insp Comp
									06-26-2007	NF	02		01	Meas/Est
									01-22-2004	PM	02		01	Meas/Est
									04-17-2002	PT	01		00	Meas/Listed-Interior Acces
									07-15-1988	ME	02		01	Meas/Est

LAND LINE VALUATION SECTION																		
B	Use Code	Description	Zone	LA	Land Units	Unit Price	Size Adj	AC Disc	Site Index	Cond.	Nbhd.	Nbhd. Adj	Notes	Location Adjustmen	Adj Unit P	Land Value		
1	1010	Single Fam M-0	RB	4	0.190	AC	176,344.00	4.23746	1.0000	5	1.00	0115	6.400	COMM INFLUENCE		1.0000	4,782,414	908,700
Total Card Land Units					0.19	AC	Parcel Total Land Area					0.19	Total Land Value				908,700	

CONSTRUCTION DETAIL			CONSTRUCTION DETAIL (CONTINUED)		
Element	Cd	Description	Element	Cd	Description
Style	01	Ranch			
Model	01	Residential			
Grade:	C+	Average Plus			
Stories	1	1 Story			
Exterior Wall 1	25	Vinyl Siding			
Exterior Wall 2					
RooF Structure	03	Gable/Hip			
RooF Cover	03	Asph/F Gls/Cmp			
Interior Wall 1	05	Drywall			
Interior Wall 2					
Interior Floor 1	12	Hardwood			
Interior Floor 2					
Heat Fuel	02	Oil			
Heat Type	05	Hot Water			
AC Type	03	Central			
Bedrooms	03	3 Bedrooms			
Full Baths	2				
Half Baths	0				
Extra Fixtures					
Total Rooms	5	5 Rooms			
Bath Style					
Kitchen Style					
Occupancy					
UsrflD 105					
Accessory Apt					
Foundation Alt	02	Conc. Block			
Rms Prts					
Bath Split	20	2 Full-0 Half			

CONDO DATA			
Parcel Id		C	Ownr 0.0
		B	S
Adjust Type	Code	Description	Factor%
Condo Flr			
Condo Unit			

COST / MARKET VALUATION	
Building Value New	480,392
Year Built	1940
Effective Year Built	1984
Depreciation Code	G
Remodel Rating	
Year Remodeled	
Depreciation %	27
Functional Obsol	0
External Obsol	0
Trend Factor	1
Condition	
Condition %	
Percent Good	73
RCNLD	350,700
Dep % Ovr	
Dep Ovr Comment	
Misc Imp Ovr	
Misc Imp Ovr Comment	
Cost to Cure Ovr	
Cost to Cure Ovr Comment	

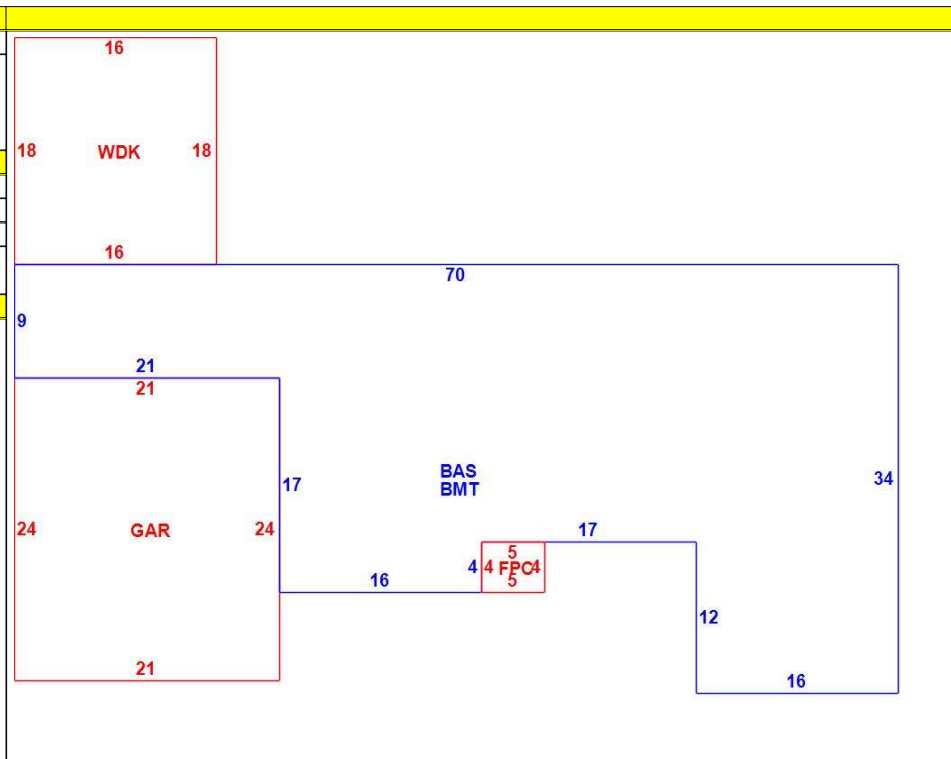

OB - OUTBUILDING & YARD ITEMS(L) / XF - BUILDING EXTRA FEATURES(B)										
Code	Description	L/B	Units	Unit Price	Yr Blt	Cond. Cd	% Gd	Grade	Grade Adj.	Appr. Value
FPL1	Fireplace 1 sto	B	1	5000.00	1984		73		0.00	3,700
DKHD	Dock-Heavy	L	1	205000.0	2003		68		0.00	139,400
WDC	Wood Decking	L	288	20.00	1996		54		0.00	3,200
FOPC	Open Prch-roo	B	20	55.00	1984		73		0.00	1,100
GAR	Attached Gara	B	504	40.00	1984		73		0.00	13,600
BMT	Basement-Unfi	B	1,523	26.01	1984		73		0.00	26,200
STRS	Stairs to Water	L	28	122.52	2003		68	C	1.00	2,300

BUILDING SUB-AREA SUMMARY SECTION						
Code	Description	Living Area	Floor Area	Eff Area	Unit Cost	Undeprec Value
BAS	First Floor	1,523	1,523	1,523	315.43	480,392
BMT	Basement Area	0	1,523	0	0.00	0
FPC	Open Porch Conc. Floor	0	20	0	0.00	0
GAR	Attached Garage	0	504	0	0.00	0
WDC	Wood Deck	0	288	0	0.00	0
Ttl Gross Liv / Lease Area		1,523	3,858	1,523		480,392

