

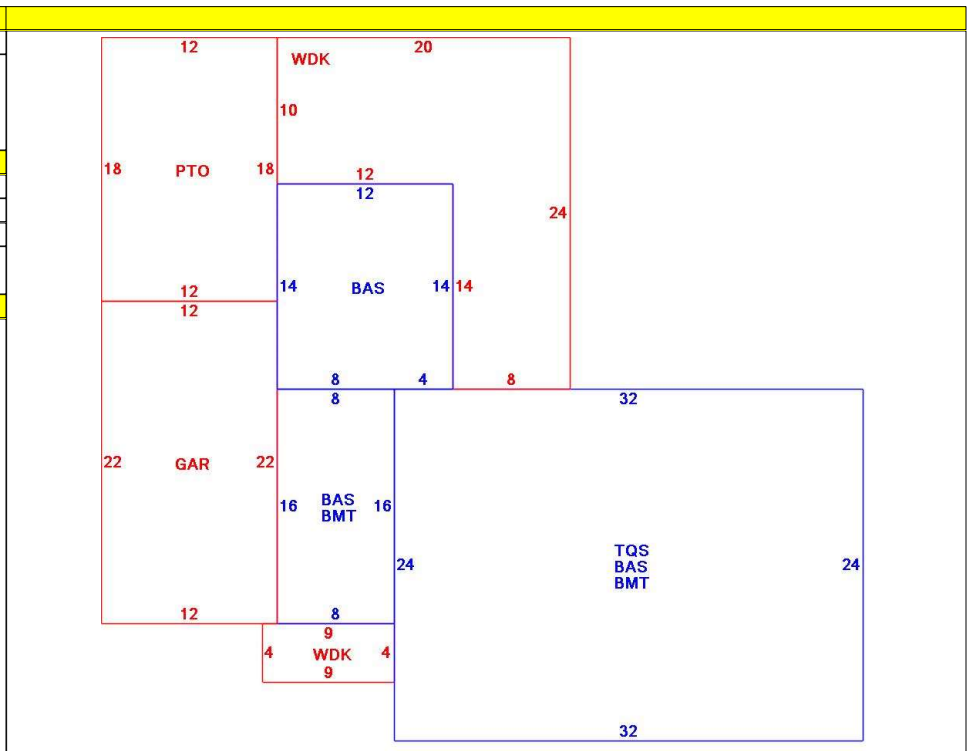

CONSTRUCTION DETAIL			CONSTRUCTION DETAIL (CONTINUED)		
Element	Cd	Description	Element	Cd	Description
Style	04	Cape Cod			
Model	01	Residential			
Grade:	C+	Average Plus			
Stories	1.75	1 3/4 Stories			
Exterior Wall 1	14	Wood Shingle			
Exterior Wall 2	11	Clapboard			
Roof Structure	03	Gable/Hip			
Roof Cover	03	Asph/F Gls/Cmp			
Interior Wall 1	05	Drywall			
Interior Wall 2					
Interior Floor 1	12	Hardwood			
Interior Floor 2					
Heat Fuel	03	Gas			
Heat Type	04	Hot Air			
AC Type	01	None			
Bedrooms	03	3 Bedrooms			
Full Baths	3				
Half Baths	0				
Extra Fixtures					
Total Rooms	5	5 Rooms			
Bath Style					
Kitchen Style					
Occupancy					
Usrflid 105					
Accessory Apt					
Foundation Alt	01	Poured Conc.			
Rms Prts					
Bath Split	30	3 Full-0 Half			
			<b>CONDO DATA</b>		
Parcel Id			C	Owne	0.0
Adjust Type		Code	Description	Factor%	
Condo Flr					
Condo Unit					
			<b>COST / MARKET VALUATION</b>		
Building Value New			428,484		
Year Built			1964		
Effective Year Built			1993		
Depreciation Code			G		
Remodel Rating					
Year Remodeled					
Depreciation %			20		
Functional Obsol			0		
External Obsol			0		
Trend Factor			1		
Condition					
Condition %					
Percent Good			80		
RCNLD			342,800		
Dep % Ovr					
Dep Ovr Comment					
Misc Imp Ovr					
Misc Imp Ovr Comment					
Cost to Cure Ovr					
Cost to Cure Ovr Comment					



OB - OUTBUILDING & YARD ITEMS(L) / XF - BUILDING EXTRA FEATURES(B)										
Code	Description	L/B	Units	Unit Price	Yr Blt	Cond. Cd	% Gd	Grade	Grade Adj.	Appr. Value
FPL2	Fireplace 1.5 s	B	1	6000.00	1995		80		0.00	4,800
BFA	Bsmt Fin-Avg	B	800	17.36	1995		80		0.00	11,100
WDC	Wood Decking	L	348	20.00	1994		50		0.00	3,400
GAR	Attached Gara	B	264	40.00	1995		80		0.00	9,700
BMT	Basement-Unfi	B	896	26.01	1995		80		0.00	19,700
SHED	Shed	L	120	18.00	1992		46		0.00	1,000
PAT2	Patio-Good	L	216	9.94	1992		73		0.00	1,700

BUILDING SUB-AREA SUMMARY SECTION						
Code	Description	Living Area	Floor Area	Eff Area	Unit Cost	Undeprec Value
BAS	First Floor	1,064	1,064	1,064	274.14	291,687
BMT	Basement Area	0	896	0	0.00	0
GAR	Attached Garage	0	264	0	0.00	0
PTO	Patio	0	216	0	0.00	0
TQS	Three Quarter Story	499	768	499	178.12	136,797
WDK	Wood Deck	0	348	0	0.00	0
Ttl Gross Liv / Lease Area		1,563	3,556	1,563		428,484

