

CURRENT OWNER		TOPO	UTILITIES	STRT / ROAD	LOCATION	CURRENT ASSESSMENT				801 FY2024 BARNSTABLE, MA VISION	
REDANZ, JAMES W & LINDA M		1 Level	1 All Public	1 Paved		Description	Code	Assessed	Assessed		
23 SCHOOL ST						RESIDNTL	1040	428,500	428,500		
HYANNIS MA 02601						RES LAND	1040	134,700	134,700		
SUPPLEMENTAL DATA						Total				563,200	563,200
Alt Prcl ID		Split Zonin		Plan Ref.							
BID Parcel		ResExpt Q		Land Ct#							
#DL 1		LOT UNNUM		#SR							
#DL 2				Life Estate							
GIS ID		F_990296_2701474		PP STATU							
				Assoc Pid#							

RECORD OF OWNERSHIP		BK-VOL/PAGE	SALE DATE	Q/U	V/I	SALE PRIC	VC	PREVIOUS ASSESSMENTS (HISTORY)								
REDANZ, JAMES W & LINDA M		3081 0154	04-11-1980	U	V	0		Year	Code	Assessed	Year	Code	Assessed	Year	Code	Assessed
								2023	1040	379,000	2022	1040	316,800	2021	1040	264,400
									1040	129,200		1040	95,700		1040	90,700
															1040	4,500
								Total		508,200	Total		412,500	Total		359,600

EXEMPTIONS				OTHER ASSESSMENTS				SIGNATURE				
Year	Code	Description	Amount	Code	Description	Number	Amount	Comm Int	This signature acknowledges a visit by a Data Collector or Assessor			
2011	5C	RESIDENTIAL EXEMPTION	0.00									
Total			0.00									

ASSESSING NEIGHBORHOOD				APPRAISED VALUE SUMMARY				
Nbhd	Nbhd Name	B	Tracing	Batch				
0104				HYAN				
NOTES				Appraised Bldg. Value (Card)				390,900
				Appraised Xf (B) Value (Bldg)				33,100
				Appraised Ob (B) Value (Bldg)				4,500
				Appraised Land Value (Bldg)				134,700
				Special Land Value				0
				Total Appraised Parcel Value				563,200
				Valuation Method				C
				Total Appraised Parcel Value				563,200

BUILDING PERMIT RECORD								VISIT / CHANGE HISTORY						
Permit Id	Issue Date	Type	Description	Amount	Insp Date	% Comp	Date Comp	Comments	Date	Id	Type	Is	Cd	Purpost/Result
									05-12-2020	WD			FR	Field Review
									11-14-2017	SR	02		03	Cycl Insp Comp
									08-26-2014	JR	03		16	In Office Review
									05-17-2012	TP	03		16	In Office Review
									05-09-2002	PT	01		00	Meas/Listed-Interior Acces

LAND LINE VALUATION SECTION																	
B	Use Code	Description	Zone	LA	Land Units	Unit Price	Size Adj	AC Disc	Site Index	Cond.	Nbhd.	Nbhd. Adj	Notes	Location Adjustmen	Adj Unit P	Land Value	
1	1040	Two Family	DN	4	0.270 AC	176,344.00	3.14262	1.0000	5	1.00	0104	0.900			1.0000	498,771.3	134,700
Total Card Land Units					0.27	AC	Parcel Total Land Area					0.27	Total Land Value			134,700	

CONSTRUCTION DETAIL			CONSTRUCTION DETAIL (CONTINUED)		
Element	Cd	Description	Element	Cd	Description
Style	04	Cape Cod			
Model	01	Residential			
Grade:	C+	Average Plus			
Stories	1.5	1 1/2 Stories			
Exterior Wall 1	14	Wood Shingle			
Exterior Wall 2	11	Clapboard			
Roof Structure	03	Gable/Hip			
Roof Cover	03	Asph/F Gls/Cmp			
Interior Wall 1	03	Plastered			
Interior Wall 2					
Interior Floor 1	12	Hardwood			
Interior Floor 2					
Heat Fuel	03	Gas			
Heat Type	05	Hot Water			
AC Type	01	None			
Bedrooms	05	5 Bedrooms			
Full Baths	2				
Half Baths	1				
Extra Fixtures					
Total Rooms	10	10 Rooms			
Bath Style					
Kitchen Style					
Occupancy					
Usrflid 105					
Accessory Apt					
Foundation Alt	11	Stone Ftgs			
Rms Prts					
Bath Split	21	2 Full-1 Half			

CONDO DATA				
Parcel Id		C		Owne 0.0
Adjust Ttp	Code	Description	Factor%	
Condo Flr				
Condo Unit				

COST / MARKET VALUATION	
Building Value New	566,497
Year Built	1840
Effective Year Built	1979
Depreciation Code	A
Remodel Rating	
Year Remodeled	
Depreciation %	31
Functional Obsol	0
External Obsol	0
Trend Factor	1
Condition	
Condition %	
Percent Good	69
RCNLD	390,900
Dep % Ovr	
Dep Ovr Comment	
Misc Imp Ovr	
Misc Imp Ovr Comment	
Cost to Cure Ovr	
Cost to Cure Ovr Comment	

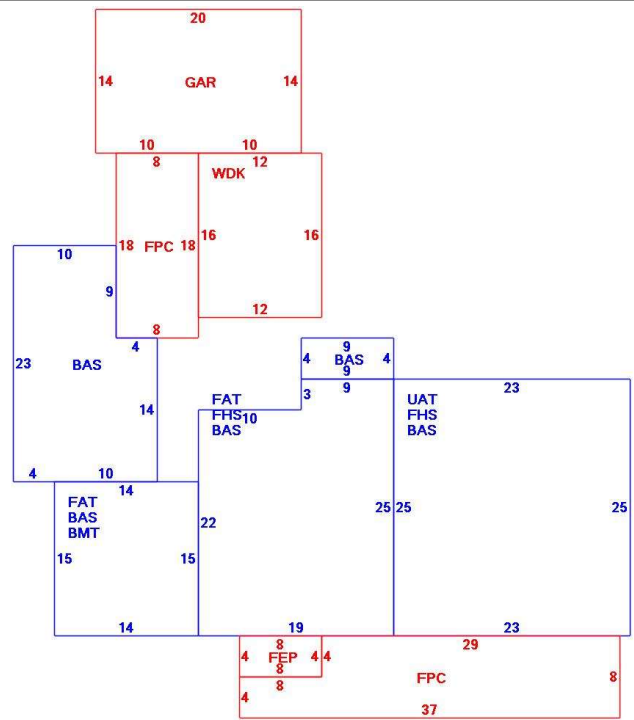

OB - OUTBUILDING & YARD ITEMS(L) / XF - BUILDING EXTRA FEATURES(B)										
Code	Description	L/B	Units	Unit Price	Yr Blt	Cond. Cd	% Gd	Grade	Grade Adj.	Appr. Value
FPL2	Fireplace 1.5 s	B	1	6000.00	1979		69		0.00	4,100
FOPC	Open Prch-roo	B	408	55.00	1979		69		0.00	10,600
FEP	Enclosed porc	B	32	70.00	1979		69		0.00	2,900
GAR	Attached Gara	B	280	40.00	1979		69		0.00	8,800
WDC	Wood Decking	L	192	20.00	2017		96		0.00	4,500
BMT	Basement-Unfi	B	210	26.01	1979		69		0.00	6,700

BUILDING SUB-AREA SUMMARY SECTION						
Code	Description	Living Area	Floor Area	Eff Area	Unit Cost	Undeprec Value
BAS	First Floor	1,552	1,552	1,552	255.41	396,395
BMT	Basement Area	0	210	0	0.00	0
FAT	Attic, Finished	98	655	98	38.21	25,030
FEP	Enclosed Porch	0	32	0	0.00	0
FHS	Half Story	510	1,020	510	127.70	130,259
FPC	Open Porch Conc. Floor	0	408	0	0.00	0
GAR	Attached Garage	0	280	0	0.00	0
UAT	Attic, Unfinished	0	575	58	25.76	14,814
WDC	Wood Deck	0	192	0	0.00	0
Ttl Gross Liv / Lease Area		2,160	4,924	2,218		566,498

