

CONSTRUCTION DETAIL			CONSTRUCTION DETAIL (CONTINUED)		
Element	Cd	Description	Element	Cd	Description
Style	14R	Apt House			
Model	03	Multi-Family			
Grade:	C+	Average Plus			
Stories	1.5	1 1/2 Stories			
Exterior Wall 1	25	Vinyl Siding			
Exterior Wall 2					
RooF Structure	03	Gable/Hip			
RooF Cover	03	Asph/F Gls/Cmp			
Interior Wall 1	03	Plastered			
Interior Wall 2					
Interior Floor 1	09	Pine/Soft Wood			
Interior Floor 2					
Heat Fuel	02	Oil			
Heat Type	06	Steam			
AC Type	01	None			
Bedrooms	05	5 Bedrooms			
Full Baths	5				
Half Baths	0				
Extra Fixtures					
Total Rooms	8	8 Rooms			
Bath Style					
Kitchen Style					
Occupancy					
UsrflD 105	11				
Accessory Apt					
Foundation Alt	11	Stone Ftgs			
Rms Prts					
Bath Split	50	5 Full-0 Half			
			CONDO DATA		
			Parcel Id	C	Owne 0.0
			Adjust Type	Code	Description Factor%
			Condo Flr		
			Condo Unit		
			COST / MARKET VALUATION		
			Building Value New		596,069
			Year Built		1843
			Effective Year Built		1984
			Depreciation Code		G
			Remodel Rating		
			Year Remodeled		
			Depreciation %		27
			Functional Obsol		5
			External Obsol		0
			Trend Factor		1
			Condition		
			Condition %		
			Percent Good		68
			RCNLD		405,300
			Dep % Ovr		
			Dep Ovr Comment		
			Misc Imp Ovr		
			Misc Imp Ovr Comment		
			Cost to Cure Ovr		
			Cost to Cure Ovr Comment		

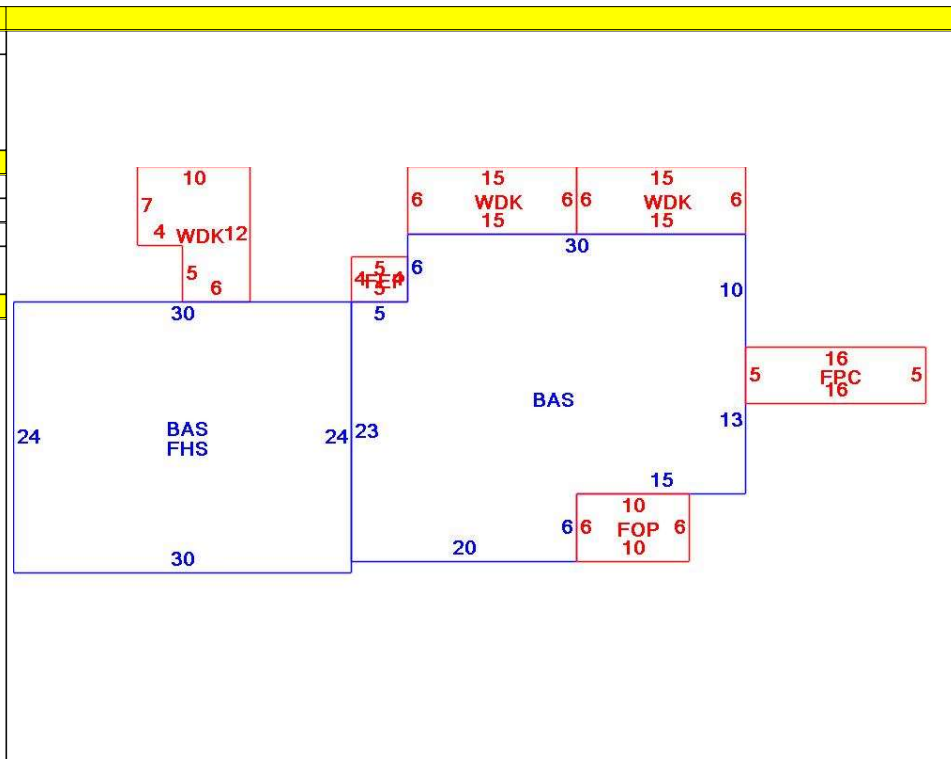

OB - OUTBUILDING & YARD ITEMS(L) / XF - BUILDING EXTRA FEATURES(B)										
Code	Description	L/B	Units	Unit Price	Yr Blt	Cond. Cd	% Gd	Grade	Grade Adj.	Appr. Value
FPL2	Fireplace 1.5 s	B	1	6000.00	1984		68		0.00	4,100
WDC	Wood Decking	L	280	20.00	1986		34		0.00	2,000
FOP	Open Porch-ro	B	60	55.00	1984		68		0.00	2,600
FOPC	Open Prch-roo	B	80	55.00	1984		68		0.00	2,700
FEP	Enclosed porc	B	20	70.00	1984		68		0.00	2,200

BUILDING SUB-AREA SUMMARY SECTION						
Code	Description	Living Area	Floor Area	Eff Area	Unit Cost	Undeprec Value
BAS	First Floor	1,615	1,615	1,615	301.81	487,418
FEP	Enclosed Porch	0	20	0	0.00	0
FHS	Half Story	360	720	360	150.90	108,650
FOP	Open Porch	0	60	0	0.00	0
FPC	Open Porch Conc. Floor	0	80	0	0.00	0
WDK	Wood Deck	0	280	0	0.00	0
Ttl Gross Liv / Lease Area		1,975	2,775	1,975		596,068



CURRENT OWNER		TOPO	UTILITIES	STRT / ROAD	LOCATION	CURRENT ASSESSMENT				
PISACANO, MARGO WHARTON & CH MAINE SEAS REALTY TRUST PO BOX 126						Description	Code	Assessed	Assessed	801 FY2024 BARNSTABLE, MA
						RESIDNTL	1120	841,300	841,300	
HYANNIS PORT MA 02647		SUPPLEMENTAL DATA				RES LAND	1120	165,000	165,000	VISION
		Alt Prcl ID Split Zonin BID Parcel ResExpt Q #DL 1 #DL 2 GIS ID F_991094_2702007	Plan Ref. Land Ct# #SR Life Estate PP STATU Assoc Pid#							
						Total		1,006,300	1,006,300	

RECORD OF OWNERSHIP		BK-VOL/PAGE	SALE DATE	Q/U	V/I	SALE PRIC	VC	PREVIOUS ASSESSMENTS (HISTORY)						
PISACANO, MARGO WHARTON & CHAR BILL, WILLIAM & ELINOR		18279	0087	03-03-2004	Q	I	900,000	00	Year	Code	Assessed	Year	Code	Assessed
		2083	0265	08-14-1974	U		0		2023	1120	812,600	2022	1120	690,900
									1120	165,000		2021	1120	624,000
									1120			1120	165,000	9,200
									Total	977,600	Total	855,900	Total	798,200

EXEMPTIONS			OTHER ASSESSMENTS					
Year	Code	Description	Amount	Code	Description	Number	Amount	Comm Int
Total			0.00					

ASSESSING NEIGHBORHOOD			
Nbhd	Nbhd Name	B	Tracing
CI09			Batch HYAN

NOTES			
This signature acknowledges a visit by a Data Collector or Assessor			
APPRAISED VALUE SUMMARY			
Appraised Bldg. Value (Card)			805,000
Appraised Xf (B) Value (Bldg)			27,100
Appraised Ob (B) Value (Bldg)			9,200
Appraised Land Value (Bldg)			165,000
Special Land Value			0
Total Appraised Parcel Value			1,006,300
Valuation Method			C
Total Appraised Parcel Value			1,006,300

BUILDING PERMIT RECORD							VISIT / CHANGE HISTORY							
Permit Id	Issue Date	Type	Description	Amount	Insp Date	% Comp	Date Comp	Comments	Date	Id	Type	Is	Cd	Purpost/Result

LAND LINE VALUATION SECTION																	
B	Use Code	Description	Zone	LA	Land Units	Unit Price	Size Adj	AC Disc	Site Index	Cond.	Nbhd.	Nbhd. Adj	Notes	Location Adjustmen	Adj Unit P	Land Value	
2	1120	APTS 9+/M-07	DV	4	0 SF	0.00	1.00000	1.0000	5	1.00	CI09	1.000		0.0000	0	0	
Total Card Land Units					0.00	SF	Parcel Total Land Area					0.00	Total Land Value				0

CURRENT OWNER		TOPO	UTILITIES	STRT / ROAD	LOCATION	CURRENT ASSESSMENT				
PISACANO, MARGO WHARTON & CH MAINE SEAS REALTY TRUST PO BOX 126						Description	Code	Assessed	Assessed	801 FY2024 BARNSTABLE, MA
						RESIDNTL	1120	841,300	841,300	
HYANNIS PORT MA 02647		SUPPLEMENTAL DATA				RES LAND	1120	165,000	165,000	VISION
		Alt Prcl ID Split Zonin BID Parcel ResExpt Q #DL 1 #DL 2 GIS ID F_991094_2702007	Plan Ref. Land Ct# #SR Life Estate PP STATU Assoc Pid#							
						Total		1,006,300	1,006,300	

RECORD OF OWNERSHIP		BK-VOL/PAGE	SALE DATE	Q/U	V/I	SALE PRIC	VC	PREVIOUS ASSESSMENTS (HISTORY)						
PISACANO, MARGO WHARTON & CHAR BILL, WILLIAM & ELINOR		18279	0087	03-03-2004	Q	I	900,000	00	Year	Code	Assessed	Year	Code	Assessed
		2083	0265	08-14-1974	U		0		2023	1120	812,600	2022	1120	690,900
									1120	165,000		2021	1120	624,000
									1120			1120	165,000	9,200
									Total	977,600	Total	855,900	Total	798,200

EXEMPTIONS			OTHER ASSESSMENTS					
Year	Code	Description	Amount	Code	Description	Number	Amount	Comm Int
Total			0.00					

ASSESSING NEIGHBORHOOD			
Nbhd	Nbhd Name	B	Tracing
CI09			Batch HYAN

NOTES			
This signature acknowledges a visit by a Data Collector or Assessor			
APPRAISED VALUE SUMMARY			
Appraised Bldg. Value (Card)			805,000
Appraised Xf (B) Value (Bldg)			27,100
Appraised Ob (B) Value (Bldg)			9,200
Appraised Land Value (Bldg)			165,000
Special Land Value			0
Total Appraised Parcel Value			1,006,300
Valuation Method			C
Total Appraised Parcel Value			1,006,300

BUILDING PERMIT RECORD							VISIT / CHANGE HISTORY							
Permit Id	Issue Date	Type	Description	Amount	Insp Date	% Comp	Date Comp	Comments	Date	Id	Type	Is	Cd	Purpost/Result

LAND LINE VALUATION SECTION																	
B	Use Code	Description	Zone	LA	Land Units	Unit Price	Size Adj	AC Disc	Site Index	Cond.	Nbhd.	Nbhd. Adj	Notes	Location Adjustmen	Adj Unit P	Land Value	
3	1120	APTS 9+/M-07	DV	4	0 SF	0.00	1.00000	1.0000	5	1.00	CI09	1.000		0.0000	0	0	
Total Card Land Units					0.00	SF	Parcel Total Land Area					0.00	Total Land Value				0

CONSTRUCTION DETAIL			CONSTRUCTION DETAIL (CONTINUED)		
Element	Cd	Description	Element	Cd	Description
Style	04	Cape Cod			
Model	01	Residential			
Grade:	C	Average			
Stories	1.75	1 3/4 Stories			
Exterior Wall 1	25	Vinyl Siding			
Exterior Wall 2					
Roof Structure	03	Gable/Hip			
Roof Cover	03	Asph/F Gls/Cmp			
Interior Wall 1	05	Drywall			
Interior Wall 2					
Interior Floor 1	14	Carpet			
Interior Floor 2					
Heat Fuel	02	Oil			
Heat Type	02	Floor Furnace			
AC Type	01	None			
Bedrooms	02	2 Bedrooms			
Full Baths	1				
Half Baths	0				
Extra Fixtures					
Total Rooms	5	5 Rooms			
Bath Style					
Kitchen Style					
Occupancy					
Usrflid 105					
Accessory Apt					
Foundation Alt	01	Poured Conc.			
Rms Prts					
Bath Split	10	1 Full-0 Half			

CONDO DATA			
Parcel Id		C	Ownr 0.0
Adjust Type	Code	Description	Factor%
Condo Flr			
Condo Unit			

COST / MARKET VALUATION		
Building Value New		269,760
Year Built		1985
Effective Year Built		1998
Depreciation Code		A
Remodel Rating		
Year Remodeled		
Depreciation %		16
Functional Obsol		0
External Obsol		0
Trend Factor		1
Condition		
Condition %		
Percent Good		84
RCNLD		226,600
Dep % Ovr		
Dep Ovr Comment		
Misc Imp Ovr		
Misc Imp Ovr Comment		
Cost to Cure Ovr		
Cost to Cure Ovr Comment		

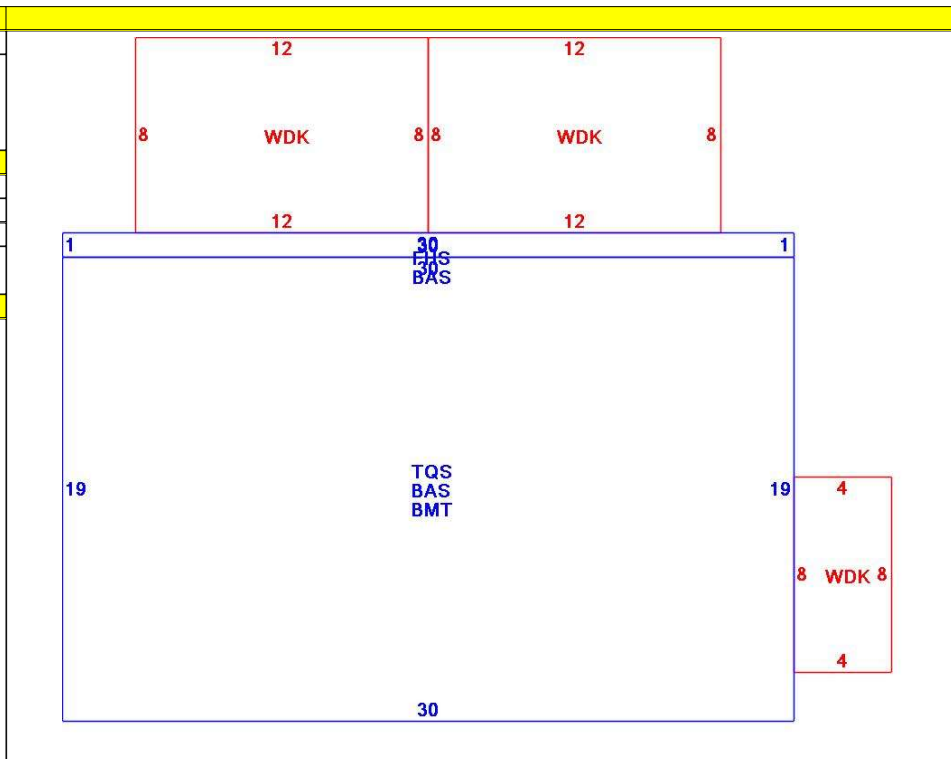

OB - OUTBUILDING & YARD ITEMS(L) / XF - BUILDING EXTRA FEATURES(B)										
Code	Description	L/B	Units	Unit Price	Yr Blt	Cond. Cd	% Gd	Grade	Grade Adj.	Appr. Value
BMT	Basement-Unfi	B	570	26.01	2000		84		0.00	15,500
WDC	Deck comp w	L	224	28.00	1999		60		0.00	4,200
SHED	Shed	L	280	18.00	1999		60		0.00	3,000

BUILDING SUB-AREA SUMMARY SECTION							
Code	Description	Living Area	Floor Area	Eff Area	Unit Cost	Undeprec Value	
BAS	First Floor	600	600	600	273.59	164,154	
BMT	Basement Area	0	570	0	0.00	0	
FHS	Half Story	15	30	15	136.80	4,104	
TQS	Three Quarter Story	371	570	371	178.07	101,502	
WDK	Wood Deck	0	224	0	0.00	0	
Ttl Gross Liv / Lease Area		986	1,994	986		269,760	

