

| CURRENT OWNER | | TOPO | UTILITIES | STRT / ROAD | LOCATION | CURRENT ASSESSMENT | | | |
|---|--|-------------|----------------|-------------|----------|--------------------|------|----------|----------|
| WHITE, LINCOLN E JR & BARBARA J 143 WEST STATE STREET GRANBY MA 01033 | | 1 Level | 2 Public Water | 1 Paved | | Description | Code | Assessed | Assessed |
| | | | 4 Gas | | | RESIDNTL | 1010 | 333,800 | 333,800 |
| | | | 6 Septic | | | RES LAND | 1010 | 279,700 | 279,700 |
| SUPPLEMENTAL DATA | | | | | | | | | |
| Alt Prcl ID | | Split Zonin | | Plan Ref. | | | | | |
| BID Parcel | | ResExpt Q | | Land Ct# | | | | | |
| #DL 1 | | #DL 2 | | Life Estate | | | | | |
| GIS ID F_990904_2718650 | | | | PP STATU | | | | | |
| | | | | Assoc Pid# | | | | | |
| | | | | | | Total | | 613,500 | 613,500 |

801
 FY2024
 BARNSTABLE, MA

VISION

| RECORD OF OWNERSHIP | | BK-VOL/PAGE | SALE DATE | Q/U | V/I | SALE PRIC | VC | PREVIOUS ASSESSMENTS (HISTORY) | | | | | | | | | |
|---------------------------------|--|-------------|-----------|------------|-----|-----------|---------|--------------------------------|---------|------|----------|------|---------|----------|-------|------|----------|
| WHITE, LINCOLN E JR & BARBARA J | | 27487 | 0194 | 06-24-2013 | Q | I | 340,000 | 00 | Year | Code | Assessed | Year | Code | Assessed | Year | Code | Assessed |
| KROEBER, JEAN C & BERND F TRS | | 18547 | 0093 | 05-04-2004 | U | I | | | 2023 | 1010 | 291,800 | 2022 | 1010 | 252,400 | 2021 | 1010 | 202,900 |
| KROEBER, JEAN | | 17206 | 0106 | 07-03-2003 | U | I | | | | 1010 | 276,700 | | 1010 | 177,300 | | 1010 | 188,300 |
| KROEBER, ANTHONY P | | 8252 | 0326 | 08-15-1993 | U | I | | | | | | | | | | 1010 | 2,900 |
| LOVELL, ANTHONY P TR | | 8724 | 0324 | 08-11-1993 | U | I | | | | | | | | | | | |
| | | | | | | Total | | | 568,500 | | Total | | 429,700 | | Total | | 394,100 |

| EXEMPTIONS | | | | OTHER ASSESSMENTS | | | | This signature acknowledges a visit by a Data Collector or Assessor | | | | | | | | | | |
|------------|------|-------------|--------|-------------------|-------------|--------|--------|---|--|--|--|--|--|--|--|--|--|--|
| Year | Code | Description | Amount | Code | Description | Number | Amount | Comm Int | | | | | | | | | | |
| | | | | | | | | | | | | | | | | | | |
| | | | Total | | | | 0.00 | | | | | | | | | | | |

| ASSESSING NEIGHBORHOOD | | | | APPRAISED VALUE SUMMARY | | | | | | | | | | |
|------------------------|-----------|---|---------|-------------------------|--|--|--|--|--|--|--|--|--|--|
| Nbhd | Nbhd Name | B | Tracing | Batch | | | | | | | | | | |
| 0108 | | | | BARNS | | | | | | | | | | |

| NOTES | | | | | | | | | | APPRAISED VALUE SUMMARY | | | | | | | | | | |
|-------|--|--|--|--|--|--|--|--|--|-------------------------------|--|--|--|--|--|--|--|--|--|---------|
| | | | | | | | | | | Appraised Bldg. Value (Card) | | | | | | | | | | 289,200 |
| | | | | | | | | | | Appraised Xf (B) Value (Bldg) | | | | | | | | | | 41,700 |
| | | | | | | | | | | Appraised Ob (B) Value (Bldg) | | | | | | | | | | 2,900 |
| | | | | | | | | | | Appraised Land Value (Bldg) | | | | | | | | | | 279,700 |
| | | | | | | | | | | Special Land Value | | | | | | | | | | 0 |
| | | | | | | | | | | Total Appraised Parcel Value | | | | | | | | | | 613,500 |
| | | | | | | | | | | Valuation Method | | | | | | | | | | C |
| | | | | | | | | | | Total Appraised Parcel Value | | | | | | | | | | 613,500 |

| BUILDING PERMIT RECORD | | | | | | | | | | VISIT / CHANGE HISTORY | | | | | | | | | |
|------------------------|------------|------|-------------|--------|------------|--------|------------|-------------------------|------------|------------------------|------|----|----|-----------------------|--|--|--|--|--|
| Permit Id | Issue Date | Type | Description | Amount | Insp Date | % Comp | Date Comp | Comments | Date | Id | Type | Is | Cd | Purpost/Result | | | | | |
| 201503559 | 06-10-2015 | NR | New Roof | 22,454 | 06-30-2015 | 100 | 06-30-2016 | RE-ROOF STRIPPING OLD S | 05-05-2020 | DM | | | FR | Field Review | | | | | |
| 79768 | 10-06-2004 | WD | Wood Deck | 2,800 | 03-22-2005 | 100 | 01-01-2005 | | 02-22-2018 | MD | 22 | | 22 | Change of Address | | | | | |
| B29601 | 07-01-1986 | AD | Addition | 15,000 | 01-15-1987 | 100 | 12-31-1987 | BA ADD'N | 10-06-2015 | SR | 02 | | 03 | Cycl Insp Comp | | | | | |
| | | | | | | | | | 08-28-2015 | NF | 03 | | 16 | In Office Review | | | | | |
| | | | | | | | | | 12-13-2013 | JR | 03 | | 20 | Sale Review | | | | | |
| | | | | | | | | | 07-31-2009 | MA | 22 | | 22 | Change of Address | | | | | |
| | | | | | | | | | 03-22-2005 | MF | 02 | | 02 | Bldg Permit Completed | | | | | |

| LAND LINE VALUATION SECTION | | | | | | | | | | | | | | | | | | | |
|-----------------------------|----------|----------------|------|----|-----------------------|------------|------------|---------|------------------------|-------|-------|-----------|-------|--------------------|------------|------------|---------|------------------|---------|
| B | Use Code | Description | Zone | LA | Land Units | Unit Price | Size Adj | AC Disc | Site Index | Cond. | Nbhd. | Nbhd. Adj | Notes | Location Adjustmen | Adj Unit P | Land Value | | | |
| 1 | 1010 | Single Fam M-0 | RF-2 | 1 | 0.590 | AC | 176,344.00 | 1.58128 | 1.0000 | 5 | 1.00 | 0108 | 1.700 | | 1.0000 | 474,047.9 | 279,700 | | |
| | | | | | Total Card Land Units | | 0.59 | AC | Parcel Total Land Area | | | | | 0.59 | | | | Total Land Value | 279,700 |

| CONSTRUCTION DETAIL | | | CONSTRUCTION DETAIL (CONTINUED) | | |
|---------------------|----|----------------|---------------------------------|----|-------------|
| Element | Cd | Description | Element | Cd | Description |
| Style | 01 | Ranch | | | |
| Model | 01 | Residential | | | |
| Grade: | C- | Average Minus | | | |
| Stories | 1 | 1 Story | | | |
| Exterior Wall 1 | 14 | Wood Shingle | | | |
| Exterior Wall 2 | | | | | |
| RooF Structure | 03 | Gable/Hip | | | |
| RooF Cover | 03 | Asph/F Gls/Cmp | | | |
| Interior Wall 1 | 05 | Drywall | | | |
| Interior Wall 2 | | | | | |
| Interior Floor 1 | 14 | Carpet | | | |
| Interior Floor 2 | | | | | |
| Heat Fuel | 02 | Oil | | | |
| Heat Type | 04 | Hot Air | | | |
| AC Type | 01 | None | | | |
| Bedrooms | 02 | 2 Bedrooms | | | |
| Full Baths | 1 | | | | |
| Half Baths | 1 | | | | |
| Extra Fixtures | | | | | |
| Total Rooms | 5 | 5 Rooms | | | |
| Bath Style | | | | | |
| Kitchen Style | | | | | |
| Occupancy | | | | | |
| Usrflid 105 | | | | | |
| Accessory Apt | | | | | |
| Foundation Alt | 02 | Conc. Block | | | |
| Rms Prts | | | | | |
| Bath Split | 11 | 1 Full-1 Half | | | |

| CONDO DATA | | | |
|-------------|------|-------------|----------|
| Parcel Id | | C | Ownr 0.0 |
| | | B | S |
| Adjust Type | Code | Description | Factor% |
| Condo Flr | | | |
| Condo Unit | | | |

| COST / MARKET VALUATION | |
|--------------------------|---------|
| Building Value New | 419,117 |
| Year Built | 1947 |
| Effective Year Built | 1979 |
| Depreciation Code | A |
| Remodel Rating | |
| Year Remodeled | |
| Depreciation % | 31 |
| Functional Obsol | 0 |
| External Obsol | 0 |
| Trend Factor | 1 |
| Condition | |
| Condition % | |
| Percent Good | 69 |
| RCNLD | 289,200 |
| Dep % Ovr | |
| Dep Ovr Comment | |
| Misc Imp Ovr | |
| Misc Imp Ovr Comment | |
| Cost to Cure Ovr | |
| Cost to Cure Ovr Comment | |

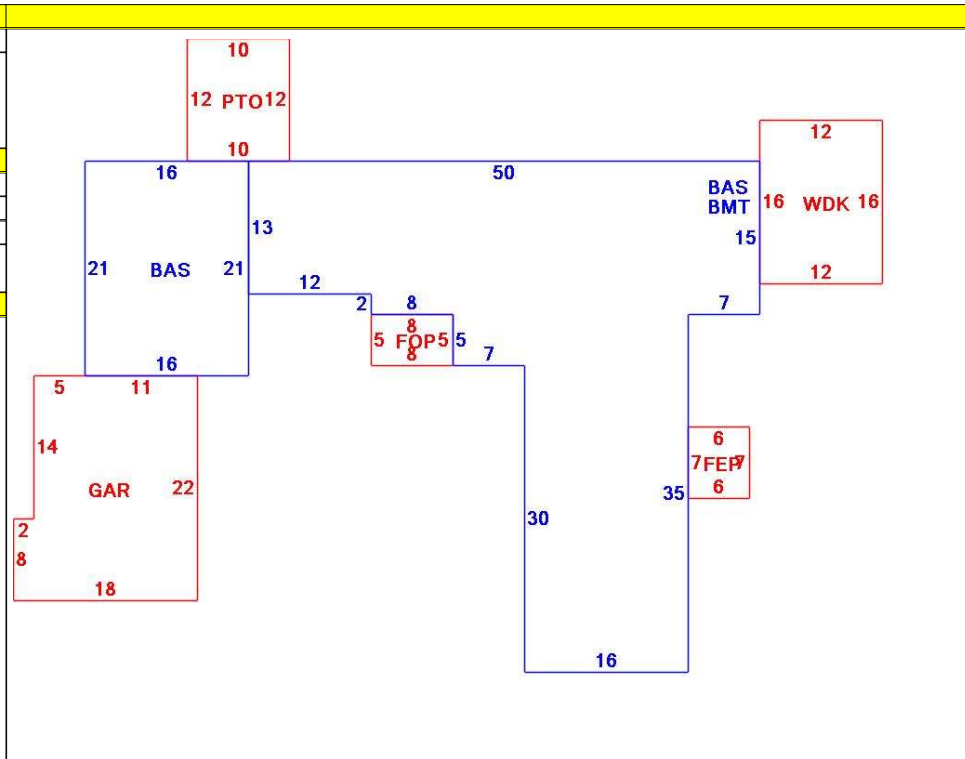

| OB - OUTBUILDING & YARD ITEMS(L) / XF - BUILDING EXTRA FEATURES(B) | | | | | | | | | | |
|--|-----------------|-----|-------|------------|--------|----------|------|-------|------------|-------------|
| Code | Description | L/B | Units | Unit Price | Yr Blt | Cond. Cd | % Gd | Grade | Grade Adj. | Appr. Value |
| FPL1 | Fireplace 1 sto | B | 1 | 5000.00 | 1981 | | 69 | | 0.00 | 3,500 |
| WDC | Wood Decking | L | 192 | 20.00 | 1990 | | 42 | | 0.00 | 1,900 |
| FOP | Open Porch-ro | B | 40 | 55.00 | 1981 | | 69 | | 0.00 | 2,000 |
| GAR | Attached Gara | B | 368 | 40.00 | 1981 | | 69 | | 0.00 | 10,500 |
| BMT | Basement-Unfi | B | 1,321 | 26.01 | 1981 | | 69 | | 0.00 | 22,300 |
| PAT2 | Patio-Good | L | 120 | 9.94 | 1991 | | 72 | | 0.00 | 1,000 |
| FEP | Enclosed porc | B | 42 | 70.00 | 1981 | | 69 | | 0.00 | 3,400 |

| BUILDING SUB-AREA SUMMARY SECTION | | | | | | |
|-----------------------------------|-----------------|-------------|------------|----------|-----------|----------------|
| Code | Description | Living Area | Floor Area | Eff Area | Unit Cost | Undeprec Value |
| BAS | First Floor | 1,657 | 1,657 | 1,657 | 252.94 | 419,117 |
| BMT | Basement Area | 0 | 1,321 | 0 | 0.00 | 0 |
| FEP | Enclosed Porch | 0 | 42 | 0 | 0.00 | 0 |
| FOP | Open Porch | 0 | 40 | 0 | 0.00 | 0 |
| GAR | Attached Garage | 0 | 368 | 0 | 0.00 | 0 |
| PTO | Patio | 0 | 120 | 0 | 0.00 | 0 |
| WDK | Wood Deck | 0 | 192 | 0 | 0.00 | 0 |
| Ttl Gross Liv / Lease Area | | 1,657 | 3,740 | 1,657 | | 419,117 |

