

CURRENT OWNER		TOPO	UTILITIES	STRT / ROAD	LOCATION	CURRENT ASSESSMENT							801 FY2024 BARNSTABLE, MA VISION				
BLAKELY, GEORGE W TR GEORGE W BLAKELY 2018 TRUST PO BOX 206 BARNSTABLE MA 02630						Description	Code	Assessed	Assessed								
		SUPPLEMENTAL DATA					RESIDNTL	1010	457,500	457,500							
		Alt Prcl ID Split Zonin BID Parcel ResExpt Q #DL 1 #DL 2 GIS ID F_989332_2717791					Plan Ref. Land Ct# #SR Life Estate PP STATU Assoc Pid#	RES LAND	1010	176,300	176,300						
						Total		633,800	633,800								
RECORD OF OWNERSHIP		BK-VOL/PAGE	SALE DATE	Q/U	V/I	SALE PRIC	VC	PREVIOUS ASSESSMENTS (HISTORY)									
BLAKELY, GEORGE W TR		33024 0206	06-29-2020	U	I	1	1F	Year	Code	Assessed	Year	Code	Assessed	Year	Code	Assessed	
BLAKELY, GEORGE W		19016 0311	09-09-2004	Q	I	318,000	00	2023	1010	389,300	2022	1010	322,600	2021	1010	261,900	
BRENNER, MALCOLM		2986 0245	09-21-1979	U		0			1010	160,300		1010	118,800		1010	118,800	
								Total		549,600	Total		441,400	Total		387,100	
EXEMPTIONS			OTHER ASSESSMENTS				This signature acknowledges a visit by a Data Collector or Assessor										
Year	Code	Description	Amount	Code	Description	Number	Amount	Comm Int									
Total			0.00														
ASSESSING NEIGHBORHOOD							APPRAISED VALUE SUMMARY Appraised Bldg. Value (Card) 421,900 Appraised Xf (B) Value (Bldg) 29,200 Appraised Ob (B) Value (Bldg) 6,400 Appraised Land Value (Bldg) 176,300 Special Land Value 0 Total Appraised Parcel Value 633,800 Valuation Method C Total Appraised Parcel Value 633,800										
Nbhd	Nbhd Name		B	Tracing		Batch											
0105						BARNs											
NOTES																	
BUILDING PERMIT RECORD										VISIT / CHANGE HISTORY							
Permit Id	Issue Date	Type	Description	Amount	Insp Date	% Comp	Date Comp	Comments		Date	Id	Type	Is	Cd	Purpost/Result		
20064033	02-12-2007	RW	Repair Work	91,000	03-21-2011	100	06-30-2011	REINSP FY11		05-05-2020	DM			FR	Field Review		
79230	09-15-2004	NS	New Siding	2,000	01-26-2005	100	01-01-2005			09-25-2015	SR	02		03	Cycl Insp Comp		
										03-29-2011	RB	03		02	Bldg Permit Completed		
										03-21-2011	MK	02		52	New Construction		
										02-12-2009	MK	02		13	CALL BACK		
										07-22-2008	JG	03		16	In Office Review		
										07-16-2008	MK	02		13	CALL BACK		
LAND LINE VALUATION SECTION																	
B	Use Code	Description	Zone	LA	Land Units	Unit Price	Size Adj	AC Disc	Site Index	Cond.	Nbhd.	Nbhd. Adj	Notes		Location Adjustmen	Adj Unit P	Land Value
1	1010	Single Fam M-0	RF-2	1	1.000	AC 176,344.00	1.00000	1.0000	5	1.00	0105	1.000			1.0000	176,344	176,300
Total Card Land Units					1.00	AC	Parcel Total Land Area					1.00	Total Land Value			176,300	

CONSTRUCTION DETAIL			CONSTRUCTION DETAIL (CONTINUED)		
Element	Cd	Description	Element	Cd	Description
Style	06	Conventional			
Model	01	Residential			
Grade:	C	Average			
Stories	1	1 Story			
Exterior Wall 1	14	Wood Shingle			
Exterior Wall 2	11	Clapboard			
RooF Structure	03	Gable/Hip			
RooF Cover	03	Asph/F Gls/Cmp			
Interior Wall 1	05	Drywall			
Interior Wall 2					
Interior Floor 1	12	Hardwood			
Interior Floor 2					
Heat Fuel	03	Gas			
Heat Type	05	Hot Water			
AC Type	03	Central			
Bedrooms	02	2 Bedrooms			
Full Baths	2				
Half Baths	0				
Extra Fixtures					
Total Rooms	5				
Bath Style					
Kitchen Style					
Occupancy					
Usrflid 105					
Accessory Apt					
Foundation Alt	08	Mixed			
Rms Prts					
Bath Split	20	2 Full-0 Half			
			CONDO DATA		
			Parcel Id	C	Ownr 0.0
			Adjust Type	Code	Description Factor%
			Condo Flr		
			Condo Unit		
			COST / MARKET VALUATION		
			Building Value New		547,967
			Year Built		1900
			Effective Year Built		1989
			Depreciation Code		VG
			Remodel Rating		
			Year Remodeled		
			Depreciation %		23
			Functional Obsol		0
			External Obsol		0
			Trend Factor		1
			Condition		
			Condition %		
			Percent Good		77
			RCNLD		421,900
			Dep % Ovr		
			Dep Ovr Comment		
			Misc Imp Ovr		
			Misc Imp Ovr Comment		
			Cost to Cure Ovr		
			Cost to Cure Ovr Comment		

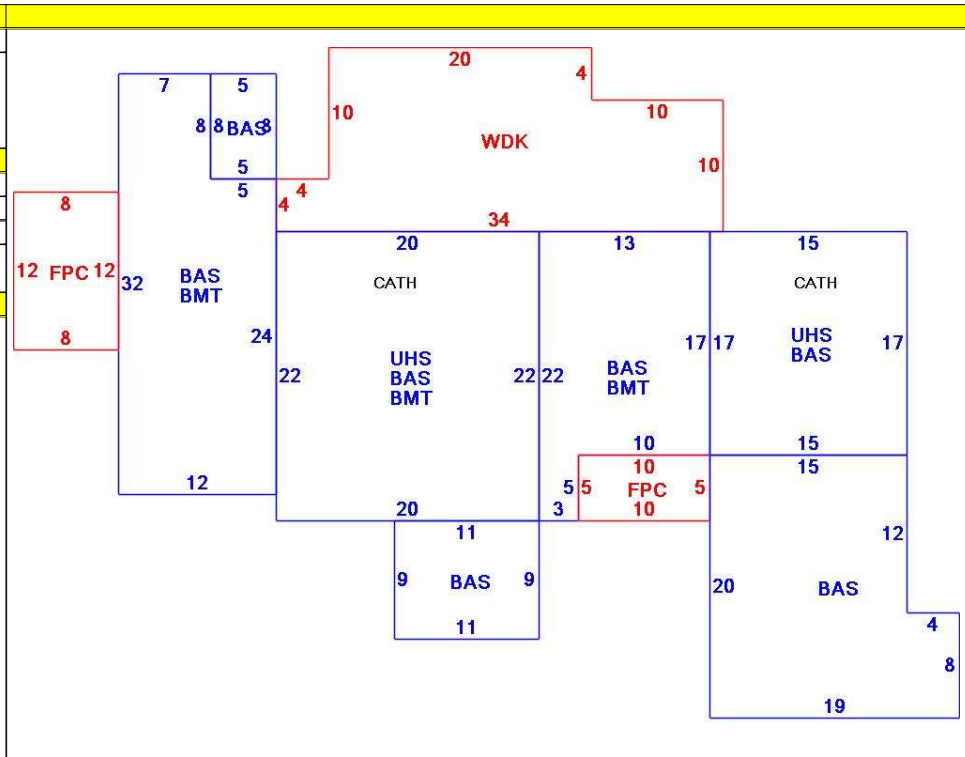

OB - OUTBUILDING & YARD ITEMS(L) / XF - BUILDING EXTRA FEATURES(B)										
Code	Description	L/B	Units	Unit Price	Yr Blt	Cond. Cd	% Gd	Grade	Grade Adj.	Appr. Value
FPL1	Fireplace 1 sto	B	1	5000.00	1989		77		0.00	3,900
WDC	Wood Decking	L	396	20.00	2011		84		0.00	6,400
FOPC	Open Prch-roo	B	146	55.00	1989		77		0.00	4,600
BMT	Basement-Unfi	B	1,020	26.01	1989		77		0.00	20,700

BUILDING SUB-AREA SUMMARY SECTION						
Code	Description	Living Area	Floor Area	Eff Area	Unit Cost	Undeprec Value
BAS	First Floor	1,746	1,746	1,746	280.29	489,386
BMT	Basement Area	0	1,020	0	0.00	0
FPC	Open Porch Conc. Floor	0	146	0	0.00	0
UHS	Half Story, Unfinished	0	695	209	84.29	58,581
WDK	Wood Deck	0	396	0	0.00	0
Ttl Gross Liv / Lease Area		1,746	4,003	1,955		547,967

