

| CURRENT OWNER | | | TOPO | UTILITIES | STRT / ROAD | LOCATION | CURRENT ASSESSMENT | | | | |
|--|--|--|--------------------------|----------------|-------------|-----------------|--|------|---|----------|--|
| STONE, HILARY M TR MALPASS TRUST 75 INDIAN TRAIL | | | 1 Level | 2 Public Water | 1 Paved | 1 Lake/Pond Fro | Description | Code | Assessed | Assessed | 801 FY2024 BARNSTABLE, MA VISION |
| | | | | 4 Gas | | | RESIDNTL | 1010 | 500,800 | 500,800 | |
| BARNSTABLE MA 02630 | | | | 6 Septic | | | RES LAND | 1010 | 647,400 | 647,400 | |
| | | | SUPPLEMENTAL DATA | | | | Alt Prcl ID Split Zonin BID Parcel ResExpt Q #DL 1 #DL 2 GIS ID F_988859_2719084 | | Plan Ref. Land Ct# #SR Life Estate PP STATU Assoc Pid# | | |

| RECORD OF OWNERSHIP | | | BK-VOL/PAGE | SALE DATE | Q/U | V/I | SALE PRIC | VC | PREVIOUS ASSESSMENTS (HISTORY) | | | | | | | | |
|---|--|--|-------------|------------|-----|-----|-----------|----|--------------------------------|------|----------|-------|------|----------|-------|------|---------|
| STONE, HILARY M TR LARGAY, RICHARD P ESTATE OF LARGAY, RICHARD P BERNE, JOHN HENRY & LEAH CARROLL, PAUL J | | | 29939 0179 | 09-16-2016 | U | I | 935,000 | 1V | Year | Code | Assessed | Year | Code | Assessed | | | |
| | | | 29939 0175 | 04-26-2016 | U | I | 0 | 1A | 2023 | 1010 | 427,200 | 2022 | 1010 | 355,200 | 2021 | 1010 | 285,300 |
| | | | 5406 0278 | 11-17-1986 | Q | I | 355,000 | U | | 1010 | 462,800 | | 1010 | 415,900 | | 1010 | 378,100 |
| | | | 4273 0202 | 10-02-1984 | Q | I | 143,750 | U | | | | | | | | 1010 | 11,300 |
| | | | 2808 0277 | 10-27-1978 | U | | 0 | | Total | | 890,000 | Total | | 771,100 | Total | | 674,700 |

| EXEMPTIONS | | | OTHER ASSESSMENTS | | | | | |
|------------|------|-------------|-------------------|------|-------------|--------|--------|----------|
| Year | Code | Description | Amount | Code | Description | Number | Amount | Comm Int |
| | | | Total | | | | 0.00 | |

| ASSESSING NEIGHBORHOOD | | | | |
|------------------------|-----------|---|---------|-------|
| Nbhd | Nbhd Name | B | Tracing | Batch |
| 0110 | | | | BARNS |

| NOTES | | |
|---|--|-----------|
| This signature acknowledges a visit by a Data Collector or Assessor | | |
| APPRAISED VALUE SUMMARY | | |
| Appraised Bldg. Value (Card) | | 455,200 |
| Appraised Xf (B) Value (Bldg) | | 34,300 |
| Appraised Ob (B) Value (Bldg) | | 11,300 |
| Appraised Land Value (Bldg) | | 647,400 |
| Special Land Value | | 0 |
| Total Appraised Parcel Value | | 1,148,200 |
| Valuation Method | | C |
| Total Appraised Parcel Value | | 1,148,200 |

| BUILDING PERMIT RECORD | | | | | | | | VISIT / CHANGE HISTORY | | | | | | |
|------------------------|------------|------|-------------|--------|------------|--------|------------|-----------------------------|------------|----|------|----|----|----------------------------|
| Permit Id | Issue Date | Type | Description | Amount | Insp Date | % Comp | Date Comp | Comments | Date | Id | Type | Is | Cd | Purpost/Result |
| 17-1742 | 06-13-2017 | 822 | Insulation | 3,865 | | 100 | | Insulation and Air Sealing. | 04-30-2020 | DM | | | FR | Field Review |
| 201107084 | 12-15-2011 | RE | Remodel | 25,500 | 02-20-2013 | 100 | 06-30-2013 | REMODO MSTRBTH-NW CABI | 08-10-2017 | MD | 22 | | 22 | Change of Address |
| 201106285 | 11-09-2011 | GN | Generator | | 02-20-2013 | 100 | 06-30-2013 | GENERATOR | 09-30-2015 | SR | 01 | | 03 | Cycl Insp Comp |
| 31458 | 06-09-1998 | AD | Addition | 12,000 | 06-01-1999 | 100 | 06-30-1999 | ADD PORCH & FARMERS P | 03-13-2013 | RB | 03 | | 16 | In Office Review |
| B27175 | 11-02-1984 | AD | Addition | 0 | 01-15-1986 | 100 | 12-31-1986 | CU ADD'N | 03-04-2013 | RB | 03 | | 16 | In Office Review |
| B27175A | 11-01-1984 | AD | Addition | 0 | 01-15-1985 | 100 | 12-31-1985 | BA ADD'N | 02-25-2013 | RB | 03 | | 02 | Bldg Permit Completed |
| B21970 | 02-01-1980 | AD | Addition | 0 | 01-15-1981 | 100 | 12-31-1981 | BA DECK/D | 09-15-2000 | PT | 01 | | 00 | Meas/Listed-Interior Acces |

| LAND LINE VALUATION SECTION | | | | | | | | | | | | | | | | |
|-----------------------------|----------|----------------|------|----|------------|---------------|------------------------|---------|------------|-------|-------|-----------|------------------|--------------------|------------|------------|
| B | Use Code | Description | Zone | LA | Land Units | Unit Price | Size Adj | AC Disc | Site Index | Cond. | Nbhd. | Nbhd. Adj | Notes | Location Adjustmen | Adj Unit P | Land Value |
| 1 | 1010 | Single Fam M-0 | RF-1 | 1 | 1.000 | AC 176,344.00 | 1.00000 | 1.0000 | 5 | 1.00 | 0110 | 3.100 | | | 1.0000 | 546,666.4 |
| 1 | 1010 | Single Fam M-0 | RF-1 | 1 | 2.280 | AC 14,250.00 | 1.00000 | 1.0000 | 0 | 1.00 | 0110 | 3.100 | | | 1.0000 | 44,175 |
| Total Card Land Units | | | | | 3.28 | AC | Parcel Total Land Area | | | | | 3.28 | Total Land Value | | | 647,400 |

| CONSTRUCTION DETAIL | | | CONSTRUCTION DETAIL (CONTINUED) | | |
|---------------------|-----|----------------|---------------------------------|----|-------------|
| Element | Cd | Description | Element | Cd | Description |
| Style | 06 | Conventional | | | |
| Model | 01 | Residential | | | |
| Grade: | C+ | Average Plus | | | |
| Stories | 1.4 | | | | |
| Exterior Wall 1 | 14 | Wood Shingle | | | |
| Exterior Wall 2 | 11 | Clapboard | | | |
| RooF Structure | 03 | Gable/Hip | | | |
| RooF Cover | 03 | Asph/F Gls/Cmp | | | |
| Interior Wall 1 | 03 | Plastered | | | |
| Interior Wall 2 | | | | | |
| Interior Floor 1 | 09 | Pine/Soft Wood | | | |
| Interior Floor 2 | | | | | |
| Heat Fuel | 02 | Oil | | | |
| Heat Type | 05 | Hot Water | | | |
| AC Type | 02 | Heat Pump | | | |
| Bedrooms | 03 | 3 Bedrooms | | | |
| Full Baths | 2 | | | | |
| Half Baths | 1 | | | | |
| Extra Fixtures | | | | | |
| Total Rooms | 7 | 7 Rooms | | | |
| Bath Style | | | | | |
| Kitchen Style | | | | | |
| Occupancy | | | | | |
| UsrflD 105 | | | | | |
| Accessory Apt | | | | | |
| Foundation Alt | 02 | Conc. Block | | | |
| Rms Prts | | | | | |
| Bath Split | 21 | 2 Full-1 Half | | | |

| CONDO DATA | | | |
|--------------------------|------|-------------|---------|
| Parcel Id | C | Owne | 0.0 |
| Adjust Type | Code | Description | Factor% |
| Condo Flr | | | |
| Condo Unit | | | |
| COST / MARKET VALUATION | | | |
| Building Value New | | 659,692 | |
| Year Built | | 1870 | |
| Effective Year Built | | 1979 | |
| Depreciation Code | | A | |
| Remodel Rating | | | |
| Year Remodeled | | | |
| Depreciation % | | 31 | |
| Functional Obsol | | 0 | |
| External Obsol | | 0 | |
| Trend Factor | | 1 | |
| Condition | | | |
| Condition % | | | |
| Percent Good | | 69 | |
| RCNLD | | 455,200 | |
| Dep % Ovr | | | |
| Dep Ovr Comment | | | |
| Misc Imp Ovr | | | |
| Misc Imp Ovr Comment | | | |
| Cost to Cure Ovr | | | |
| Cost to Cure Ovr Comment | | | |

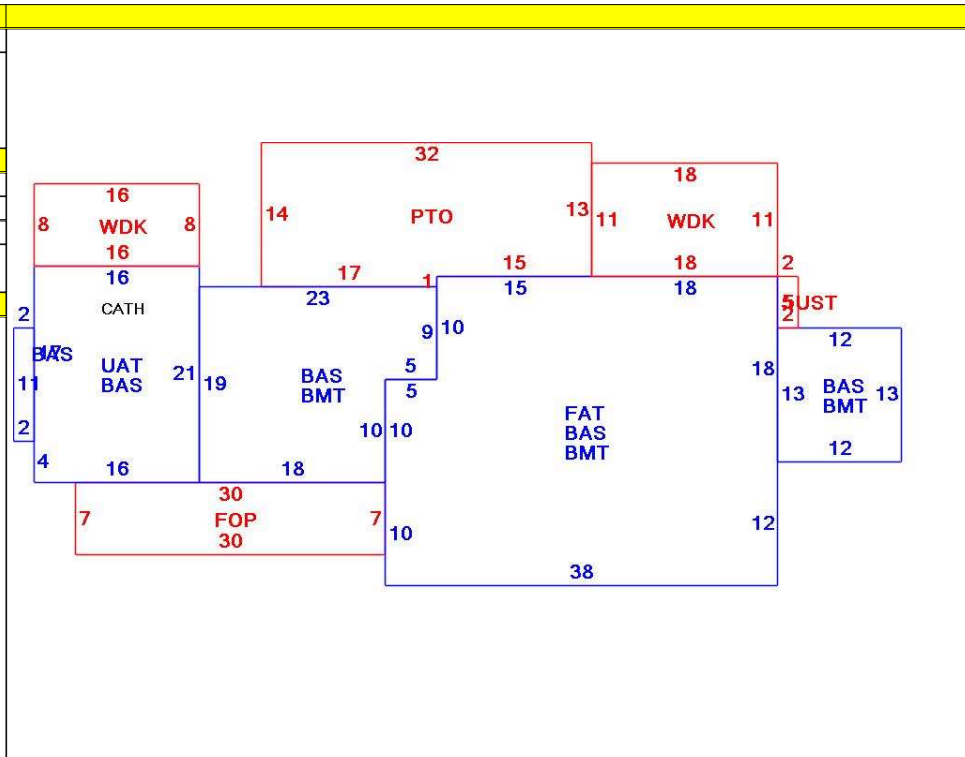

| OB - OUTBUILDING & YARD ITEMS(L) / XF - BUILDING EXTRA FEATURES(B) | | | | | | | | | | |
|--|------------------|-----|-------|------------|--------|----------|------|-------|------------|-------------|
| Code | Description | L/B | Units | Unit Price | Yr Blt | Cond. Cd | % Gd | Grade | Grade Adj. | Appr. Value |
| FPLG | Gas Fireplace | B | 1 | 2500.00 | 1979 | | 69 | | 0.00 | 1,700 |
| WDC | Wood Decking | L | 308 | 20.00 | 1986 | | 34 | | 0.00 | 2,100 |
| PATC | Conc Pavers | L | 433 | 15.46 | 1986 | | 67 | | 0.00 | 4,400 |
| FOP | Open Porch-ro | B | 210 | 55.00 | 1979 | | 69 | | 0.00 | 6,400 |
| BMT | Basement-Unfi | B | 1,633 | 26.01 | 1979 | | 69 | | 0.00 | 26,000 |
| GEN | Emergency Ge | L | 1 | 5550.00 | 2012 | | 86 | | 0.00 | 4,800 |
| UST | Utility Storage- | B | 10 | 17.11 | 1979 | | 69 | | 0.00 | 200 |

| BUILDING SUB-AREA SUMMARY SECTION | | | | | | |
|-----------------------------------|-------------------|-------------|------------|----------|-----------|----------------|
| Code | Description | Living Area | Floor Area | Eff Area | Unit Cost | Undeprec Value |
| BAS | First Floor | 1,991 | 1,991 | 1,991 | 301.37 | 600,022 |
| BMT | Basement Area | 0 | 1,633 | 0 | 0.00 | 0 |
| FAT | Attic, Finished | 164 | 1,090 | 164 | 45.34 | 49,424 |
| FOP | Open Porch | 0 | 210 | 0 | 0.00 | 0 |
| PTO | Patio | 0 | 433 | 0 | 0.00 | 0 |
| UAT | Attic, Unfinished | 0 | 336 | 34 | 30.50 | 10,246 |
| UST | Utility Enclosure | 0 | 10 | 0 | 0.00 | 0 |
| WDK | Wood Deck | 0 | 326 | 0 | 0.00 | 0 |
| Ttl Gross Liv / Lease Area | | 2,155 | 6,029 | 2,189 | | 659,692 |

