

| CURRENT OWNER   |   |        | TOPO | UTILITIES    | STRT / ROAD   | LOCATION | CURRENT ASSESSMENT                   |                      |                                |                                |  |
|---|---|--------|------|--------------|---|----------|--------------------------------------|----------------------|--------------------------------|--------------------------------|--|
| DOW, WILLIAM STONE & GOLDSTEIN<br><br>PO BOX 366<br><br>CUMMAQUID MA 02637  | 1 | Level  | 2    | Public Water | 1   | Paved    | Description<br>RESIDENTL<br>RES LAND | Code<br>1010<br>1010 | Assessed<br>409,000<br>558,200 | Assessed<br>409,000<br>558,200 | 801<br><br>FY2024<br>BARNSTABLE, MA<br><br><b>VISION</b> |
|   | 4 | Gas    |      |              |   |          |                                      |                      |                                |                                |  |
|   | 6 | Septic |      |              |   |          |                                      |                      |                                |                                |  |
| SUPPLEMENTAL DATA   |   |        |      |              |   |          |                                      |                      |                                |                                |  |
| Alt Prcl ID<br>Split Zonin RF-1;RF-2<br>BID Parcel<br>ResExpt Q YES:<br>#DL 1<br>#DL 2<br>GIS ID F_990457_2719108 |   |        |      |              | Plan Ref.<br>Land Ct#<br>#SR<br>Life Estate<br>PP STATU<br>Assoc Pid# |          | Total                                |                      | 967,200                        | 967,200                        |  |

| RECORD OF OWNERSHIP               |       |      | BK-VOL/PAGE | SALE DATE | Q/U | V/I     | SALE PRIC | VC    | PREVIOUS ASSESSMENTS (HISTORY) |          |       |      |          |       |      |          |
|-----------------------------------|-------|------|-------------|-----------|-----|---------|-----------|-------|--------------------------------|----------|-------|------|----------|-------|------|----------|
| DOW, WILLIAM STONE & GOLDSTEIN, J | 30048 | 0277 | 10-31-2016  | U         | I   | 350,000 | 1A        | Year  | Code                           | Assessed | Year  | Code | Assessed | Year  | Code | Assessed |
| GOLDSTEIN, JEFFREY & BEA MARIE TR | 21583 | 0130 | 12-05-2006  | U         | I   | 1       | 1A        | 2023  | 1010                           | 366,300  | 2022  | 1010 | 311,900  | 2021  | 1010 | 244,800  |
| GOLDSTEIN, JEFFREY & BEA MARIE    | 6882  | 0082 | 09-15-1989  | Q         | I   | 125,000 | U         |       | 1010                           | 393,700  |       | 1010 | 336,800  |       | 1010 | 306,200  |
| BURLING, RICHARD S EXECUTOR       | 6882  | 0079 | 07-15-1988  | U         | I   | 1       | A         |       |                                |          |       |      |          |       | 1010 | 5,800    |
| ERNST, RICHARD JR                 | 6053  | 0014 | 12-08-1987  | U         | O   | 145,000 | O         | Total |                                | 760,000  | Total |      | 648,700  | Total |      | 556,800  |

| EXEMPTIONS |      |                       |        | OTHER ASSESSMENTS |             |        |        | This signature acknowledges a visit by a Data Collector or Assessor |  |  |  |  |  |  |  |  |  |  |  |  |
|------------|------|-----------------------|--------|-------------------|-------------|--------|--------|---|--|--|--|--|--|--|--|--|--|--|--|--|
| Year       | Code | Description           | Amount | Code              | Description | Number | Amount | Comm Int  |  |  |  |  |  |  |  |  |  |  |  |  |
| 2018       | 5C   | RESIDENTIAL EXEMPTION | 0.00   |                   |             |        |        |   |  |  |  |  |  |  |  |  |  |  |  |  |
| Total      |      |                       | 0.00   |                   |             |        |        |   |  |  |  |  |  |  |  |  |  |  |  |  |

| ASSESSING NEIGHBORHOOD |           |   |         | APPRAISED VALUE SUMMARY |  |  |  |
|------------------------|-----------|---|---------|-------------------------|--|--|--|
| Nbhd                   | Nbhd Name | B | Tracing | Batch                   |  |  |  |
| 0110                   |           |   | BARNS   |                         |  |  |  |

| NOTES |  |  |  |  |  |  |  |  |  |  |  | APPRAISED VALUE SUMMARY       |         |  |  |
|-------|--|--|--|--|--|--|--|--|--|--|--|-------------------------------|---------|--|--|
|       |  |  |  |  |  |  |  |  |  |  |  | Appraised Bldg. Value (Card)  | 381,400 |  |  |
|       |  |  |  |  |  |  |  |  |  |  |  | Appraised Xf (B) Value (Bldg) | 19,600  |  |  |
|       |  |  |  |  |  |  |  |  |  |  |  | Appraised Ob (B) Value (Bldg) | 8,000   |  |  |
|       |  |  |  |  |  |  |  |  |  |  |  | Appraised Land Value (Bldg)   | 558,200 |  |  |
|       |  |  |  |  |  |  |  |  |  |  |  | Special Land Value            | 0       |  |  |
|       |  |  |  |  |  |  |  |  |  |  |  | Total Appraised Parcel Value  | 967,200 |  |  |
|       |  |  |  |  |  |  |  |  |  |  |  | Valuation Method              | C       |  |  |
|       |  |  |  |  |  |  |  |  |  |  |  | Total Appraised Parcel Value  | 967,200 |  |  |

| BUILDING PERMIT RECORD |            |      |                 |        |            |        |            |                              |  | VISIT / CHANGE HISTORY |    |      |    |    |                            |
|------------------------|------------|------|-----------------|--------|------------|--------|------------|------------------------------|--|------------------------|----|------|----|----|----------------------------|
| Permit Id              | Issue Date | Type | Description     | Amount | Insp Date  | % Comp | Date Comp  | Comments                     |  | Date                   | Id | Type | Is | Cd | Purpost/Result             |
| EXPR-23-5              | 04-26-2023 | 835  | Sid/Wind/Roof/  | 3,100  | 06-30-2023 | 100    | 06-30-2023 | WEATHERIZATION, AIR SEA      |  | 01-30-2023             | SR | 01   |    | 02 | Bldg Permit Completed      |
| SHED-22-1              | 11-29-2022 | 863  | Shed Registrati | 0      | 01-30-2023 | 100    | 06-30-2023 |                              |  | 04-30-2020             | DM |      |    | FR | Field Review               |
| BLDR-22-88             | 10-05-2022 | 839  | Solar Panel-Re  | 12,225 | 01-30-2023 | 100    | 06-30-2023 | (17) Roof mounted black 400- |  | 02-23-2018             | GC | 03   |    | 16 | In Office Review           |
| 17-925                 | 04-06-2017 | 822  | Insulation      | 4,975  | 06-30-2017 | 100    | 06-30-2017 | Weatherization               |  | 02-01-2017             | AL | 22   |    | 22 | Change of Address          |
| B31572                 | 01-01-1988 | AD   | Addition        | 80,000 | 01-15-1990 | 100    | 06-30-1990 | BA ADD'N                     |  | 03-29-2016             | SR | 02   |    | 03 | Cycl Insp Comp             |
|                        |            |      |                 |        |            |        |            |                              |  | 08-17-2000             | PT | 01   |    | 00 | Meas/Listed-Interior Acces |
|                        |            |      |                 |        |            |        |            |                              |  | 10-15-1993             | ML | 01   |    | 00 | Meas/Listed-Interior Acces |

| LAND LINE VALUATION SECTION |          |                |      |    |            |               |                        |         |            |       |       |           |                  |  |                    |            |            |
|-----------------------------|----------|----------------|------|----|------------|---------------|------------------------|---------|------------|-------|-------|-----------|------------------|--|--------------------|------------|------------|
| B                           | Use Code | Description    | Zone | LA | Land Units | Unit Price    | Size Adj               | AC Disc | Site Index | Cond. | Nbhd. | Nbhd. Adj | Notes            |  | Location Adjustmen | Adj Unit P | Land Value |
| 1                           | 1010     | Single Fam M-0 | SPLI | 1  | 1.000      | AC 176,344.00 | 1.00000                | 1.0000  | 5          | 1.00  | 0110  | 3.100     |                  |  | 1.0000             | 546,666.4  | 546,700    |
| 1                           | 1010     | Single Fam M-0 | SPLI | 1  | 0.260      | AC 14,250.00  | 1.00000                | 1.0000  | 0          | 1.00  | 0110  | 3.100     |                  |  | 1.0000             | 44,175     | 11,500     |
| Total Card Land Units       |          |                |      |    | 1.26       | AC            | Parcel Total Land Area |         |            |       |       | 1.26      | Total Land Value |  |                    | 558,200    |            |

| CONSTRUCTION DETAIL |    |                | CONSTRUCTION DETAIL (CONTINUED)      |    |             |
|---------------------|----|----------------|--------------------------------------|----|-------------|
| Element             | Cd | Description    | Element                              | Cd | Description |
| Style               | 04 | Cape Cod       |                                      |    |             |
| Model               | 01 | Residential    |                                      |    |             |
| Grade:              | C  | Average        |                                      |    |             |
| Stories             | 1  | 1 Story        |                                      |    |             |
| Exterior Wall 1     | 14 | Wood Shingle   |                                      |    |             |
| Exterior Wall 2     |    |                |                                      |    |             |
| RooF Structure      | 03 | Gable/Hip      |                                      |    |             |
| RooF Cover          | 03 | Asph/F Gls/Cmp |                                      |    |             |
| Interior Wall 1     | 05 | Drywall        |                                      |    |             |
| Interior Wall 2     |    |                |                                      |    |             |
| Interior Floor 1    | 14 | Carpet         |                                      |    |             |
| Interior Floor 2    | 12 | Hardwood       |                                      |    |             |
| Heat Fuel           | 03 | Gas            |                                      |    |             |
| Heat Type           | 05 | Hot Water      |                                      |    |             |
| AC Type             | 03 | Central        |                                      |    |             |
| Bedrooms            | 03 | 3 Bedrooms     |                                      |    |             |
| Full Baths          | 2  |                |                                      |    |             |
| Half Baths          | 0  |                |                                      |    |             |
| Extra Fixtures      |    |                |                                      |    |             |
| Total Rooms         | 7  | 7 Rooms        |                                      |    |             |
| Bath Style          |    |                |                                      |    |             |
| Kitchen Style       |    |                |                                      |    |             |
| Occupancy           |    |                |                                      |    |             |
| Usrflid 105         |    |                |                                      |    |             |
| Accessory Apt       |    |                |                                      |    |             |
| Foundation Alt      | 01 | Poured Conc.   |                                      |    |             |
| Rms Prts            |    |                |                                      |    |             |
| Bath Split          | 20 | 2 Full-0 Half  |                                      |    |             |
|                     |    |                | <b>CONDO DATA</b>                    |    |             |
|                     |    |                | Parcel Id                            | C  | Owne   0.0  |
|                     |    |                | Adjust Type Code Description Factor% |    |             |
|                     |    |                | Condo Flr                            |    |             |
|                     |    |                | Condo Unit                           |    |             |
|                     |    |                | <b>COST / MARKET VALUATION</b>       |    |             |
|                     |    |                | Building Value New                   |    | 495,380     |
|                     |    |                | Year Built                           |    | 1959        |
|                     |    |                | Effective Year Built                 |    | 1990        |
|                     |    |                | Depreciation Code                    |    | G           |
|                     |    |                | Remodel Rating                       |    |             |
|                     |    |                | Year Remodeled                       |    |             |
|                     |    |                | Depreciation %                       |    | 23          |
|                     |    |                | Functional Obsol                     |    | 0           |
|                     |    |                | External Obsol                       |    | 0           |
|                     |    |                | Trend Factor                         |    | 1           |
|                     |    |                | Condition                            |    |             |
|                     |    |                | Condition %                          |    |             |
|                     |    |                | Percent Good                         |    | 77          |
|                     |    |                | RCNLD                                |    | 381,400     |
|                     |    |                | Dep % Ovr                            |    |             |
|                     |    |                | Dep Ovr Comment                      |    |             |
|                     |    |                | Misc Imp Ovr                         |    |             |
|                     |    |                | Misc Imp Ovr Comment                 |    |             |
|                     |    |                | Cost to Cure Ovr                     |    |             |
|                     |    |                | Cost to Cure Ovr Comment             |    |             |

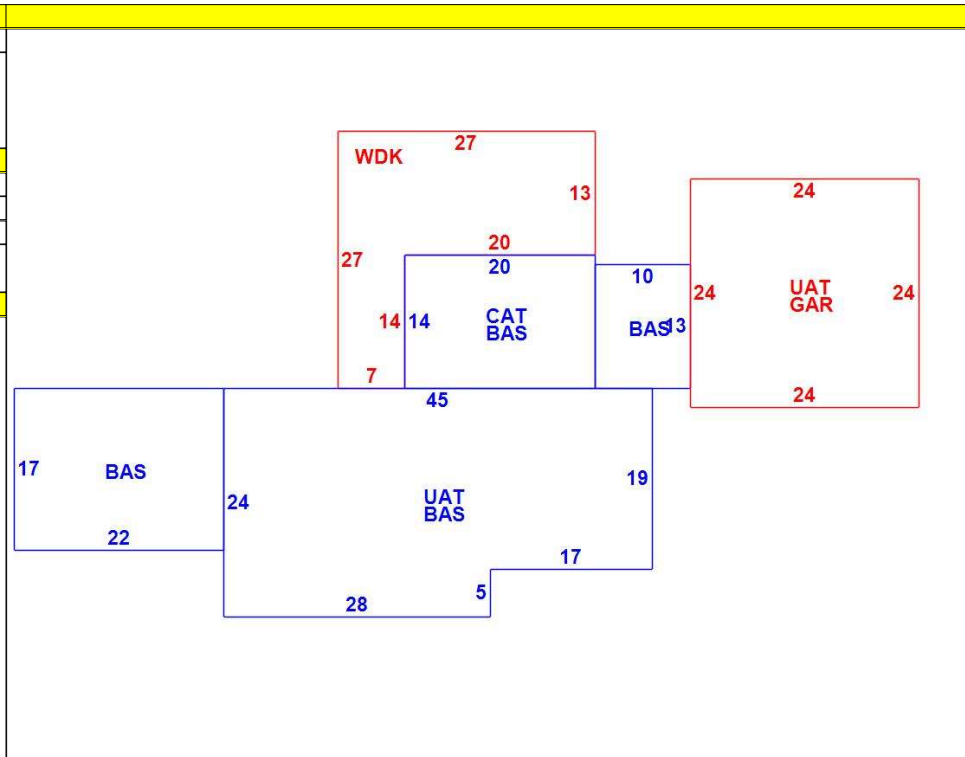

| OB - OUTBUILDING & YARD ITEMS(L) / XF - BUILDING EXTRA FEATURES(B) |                 |     |       |            |        |          |      |       |            |             |
|--|-----------------|-----|-------|------------|--------|----------|------|-------|------------|-------------|
| Code   | Description     | L/B | Units | Unit Price | Yr Blt | Cond. Cd | % Gd | Grade | Grade Adj. | Appr. Value |
| FPL1   | Fireplace 1 sto | B   | 1     | 5000.00    | 1992   |          | 77   |       | 0.00       | 3,900       |
| GAR  | Attached Gara   | B   | 576   | 40.00      | 1992   |          | 77   |       | 0.00       | 15,700      |
| WDC  | Wood Deck w/    | L   | 449   | 18.00      | 1998   |          | 58   |       | 0.00       | 4,500       |
| SOL1   | Solar PV Pane   | B   | 17    | 860.00     | 1992   |          | 0    |       | 0.00       | 0           |
| SHED   | Shed            | L   | 192   | 18.00      | 2023   |          | 100  |       | 0.00       | 3,500       |

| BUILDING SUB-AREA SUMMARY SECTION |                   |             |            |          |           |                |
|-----------------------------------|-------------------|-------------|------------|----------|-----------|----------------|
| Code                              | Description       | Living Area | Floor Area | Eff Area | Unit Cost | Undeprec Value |
| BAS                               | First Floor       | 1,779       | 1,779      | 1,779    | 252.23    | 448,717        |
| CAT                               | Cathedral         | 0           | 280        | 28       | 25.22     | 7,062          |
| GAR                               | Attached Garage   | 0           | 576        | 0        | 0.00      | 0              |
| UAT                               | Attic, Unfinished | 0           | 1,571      | 157      | 25.21     | 39,600         |
| WDC                               | Wood Deck         | 0           | 449        | 0        | 0.00      | 0              |
| Ttl Gross Liv / Lease Area        |                   | 1,779       | 4,655      | 1,964    |           | 495,379        |

