

| CURRENT OWNER | | TOPO | UTILITIES | STRT / ROAD | LOCATION | CURRENT ASSESSMENT | | | | 801 FY2024 BARNSTABLE, MA VISION | |
|---|--|----------------|----------------|------------------------|----------|--------------------|------|----------|----------|--|-----------|
| ANDERSON, PATRICIA A JONES PO BOX 14 CUMMAQUID MA 02637 | | 1 Level | 6 Septic | 1 Paved | | Description | Code | Assessed | Assessed | | |
| | | | 4 Gas | | | RESIDNTL | 1010 | 607,300 | 607,300 | | |
| | | | 2 Public Water | | | RES LAND | 1010 | 537,500 | 537,500 | | |
| SUPPLEMENTAL DATA | | | | | | Total | | | | 1,144,800 | 1,144,800 |
| Alt Prcl ID | | Split Zonin | | Plan Ref. 228/131 SH 2 | | | | | | | |
| BID Parcel | | ResExpt Q YES: | | Land Ct# | | | | | | | |
| #DL 1 LOT 19A | | #DL 2 | | Life Estate | | | | | | | |
| GIS ID F_990236_2719420 | | Assoc Pid# | | | | | | | | | |

| RECORD OF OWNERSHIP | | BK-VOL/PAGE | SALE DATE | Q/U | V/I | SALE PRIC | VC | PREVIOUS ASSESSMENTS (HISTORY) | | | | | | | | | |
|--------------------------------|--|-------------|-----------|------------|-----|-----------|----|--------------------------------|-------|------|----------|-------|------|----------|-------|--|---------|
| ANDERSON, PATRICIA A JONES | | 28160 | 0137 | 05-23-2014 | U | I | 1 | 1A | Year | Code | Assessed | Year | Code | Assessed | | | |
| ANDERSON, WAYNE E & PATRICIA A | | 1435 | 0873 | 05-06-1969 | U | | 0 | | 2023 | 1010 | 517,800 | 2022 | 1010 | 432,900 | | | |
| | | | | | | | | | | 1010 | 378,300 | | 1010 | 321,100 | | | |
| | | | | | | | | | | | | 2021 | 1010 | 405,900 | | | |
| | | | | | | | | | | | | | 1010 | 291,900 | | | |
| | | | | | | | | | | | | | 1010 | 7,900 | | | |
| | | | | | | | | | Total | | 896,100 | Total | | 754,000 | Total | | 705,700 |

| EXEMPTIONS | | | | OTHER ASSESSMENTS | | | | This signature acknowledges a visit by a Data Collector or Assessor | | | | | | | | | | |
|------------|------|-----------------------|--------|-------------------|-------------|--------|--------|---|--|--|--|--|--|--|--|--|--|--|
| Year | Code | Description | Amount | Code | Description | Number | Amount | Comm Int | | | | | | | | | | |
| 2010 | 5C | RESIDENTIAL EXEMPTION | 0.00 | | | | | | | | | | | | | | | |
| Total | | | 0.00 | | | | | | | | | | | | | | | |

| ASSESSING NEIGHBORHOOD | | | | APPRAISED VALUE SUMMARY | | | | |
|------------------------|-----------|---|---------|-------------------------|-------------------------------|-----------|--|--|
| Nbhd | Nbhd Name | B | Tracing | Batch | | | | |
| 0110 | | | | BARNS | Appraised Bldg. Value (Card) | 539,000 | | |
| | | | | | Appraised Xf (B) Value (Bldg) | 60,400 | | |
| | | | | | Appraised Ob (B) Value (Bldg) | 7,900 | | |
| | | | | | Appraised Land Value (Bldg) | 537,500 | | |
| | | | | | Special Land Value | 0 | | |
| | | | | | Total Appraised Parcel Value | 1,144,800 | | |
| | | | | | Valuation Method | C | | |
| | | | | | Total Appraised Parcel Value | 1,144,800 | | |

| NOTES | | | | | | | | | | VISIT / CHANGE HISTORY | | | | | |
|-------|--|--|--|--|--|--|--|--|--|------------------------|----|------|----|----|----------------------------|
| | | | | | | | | | | Date | Id | Type | Is | Cd | Purpost/Result |
| | | | | | | | | | | 02-01-2021 | CK | 22 | | 22 | Change of Address |
| | | | | | | | | | | 04-30-2020 | DM | | | FR | Field Review |
| | | | | | | | | | | 10-05-2015 | SR | 02 | | 03 | Cycl Insp Comp |
| | | | | | | | | | | 02-19-2015 | JR | 03 | | 03 | Cycl Insp Comp |
| | | | | | | | | | | 05-17-2007 | JG | 03 | | 52 | New Construction |
| | | | | | | | | | | 11-07-2006 | MF | 02 | | 02 | Bldg Permit Completed |
| | | | | | | | | | | 09-18-2000 | MF | 01 | | 00 | Meas/Listed-Interior Acces |

| BUILDING PERMIT RECORD | | | | | | | | | | LAND LINE VALUATION SECTION | | | | | |
|------------------------|------------|------|----------------|---------|------------|--------|------------|-----------|--|-----------------------------|----|------|----|----|----------------------------|
| Permit Id | Issue Date | Type | Description | Amount | Insp Date | % Comp | Date Comp | Comments | | Date | Id | Type | Is | Cd | Purpost/Result |
| 17-2439 | 08-02-2017 | 835 | Sid/Wind/Roof/ | 7,100 | | 100 | | re-side | | 02-01-2021 | CK | 22 | | 22 | Change of Address |
| 82962 | 03-25-2005 | AD | Addition | 190,000 | 12-07-2006 | 100 | 06-30-2007 | | | 04-30-2020 | DM | | | FR | Field Review |
| B31995 | 06-01-1988 | AD | Addition | 20,000 | 01-15-1989 | 100 | 06-30-2007 | BA GARAGE | | 10-05-2015 | SR | 02 | | 03 | Cycl Insp Comp |
| | | | | | | | | | | 02-19-2015 | JR | 03 | | 03 | Cycl Insp Comp |
| | | | | | | | | | | 05-17-2007 | JG | 03 | | 52 | New Construction |
| | | | | | | | | | | 11-07-2006 | MF | 02 | | 02 | Bldg Permit Completed |
| | | | | | | | | | | 09-18-2000 | MF | 01 | | 00 | Meas/Listed-Interior Acces |

| B | Use Code | Description | Zone | LA | Land Units | Unit Price | Size Adj | AC Disc | Site Index | Cond. | Nbhd. | Nbhd. Adj | Notes | Location Adjustmen | Adj Unit P | Land Value | |
|-----------------------|----------|----------------|------|----|------------|------------|------------------------|---------|------------|-------|-------|-----------|------------------|--------------------|------------|------------|---------|
| 1 | 1010 | Single Fam M-0 | RF-1 | 1 | 0.820 | AC | 176,344.00 | 1.19913 | 1.0000 | 5 | 1.00 | 0110 | 3.100 | | 1.0000 | 655,523.5 | 537,500 |
| Total Card Land Units | | | | | 0.82 | AC | Parcel Total Land Area | | | | | 0.82 | Total Land Value | | | 537,500 | |

| CONSTRUCTION DETAIL | | | CONSTRUCTION DETAIL (CONTINUED) | | |
|---------------------|-----|----------------|---------------------------------|------|-------------|
| Element | Cd | Description | Element | Cd | Description |
| Style | 63 | Gambrel | | | |
| Model | 01 | Residential | | | |
| Grade: | C+ | Average Plus | | | |
| Stories | 1.8 | | | | |
| Exterior Wall 1 | 14 | Wood Shingle | | | |
| Exterior Wall 2 | | | | | |
| RooF Structure | 03 | Gable/Hip | | | |
| RooF Cover | 03 | Asph/F Gls/Cmp | | | |
| Interior Wall 1 | 05 | Drywall | | | |
| Interior Wall 2 | | | | | |
| Interior Floor 1 | 12 | Hardwood | | | |
| Interior Floor 2 | 14 | Carpet | | | |
| Heat Fuel | 02 | Oil | | | |
| Heat Type | 05 | Hot Water | | | |
| AC Type | 01 | None | | | |
| Bedrooms | 03 | 3 Bedrooms | | | |
| Full Baths | 2 | | | | |
| Half Baths | 1 | | | | |
| Extra Fixtures | | | | | |
| Total Rooms | 8 | | | | |
| Bath Style | | | | | |
| Kitchen Style | | | | | |
| Occupancy | 1 | | | | |
| Usrflid 105 | | | | | |
| Accessory Apt | | | | | |
| Foundation Alt | 01 | Poured Conc. | | | |
| Rms Prts | | | | | |
| Bath Split | 21 | 2 Full-1 Half | | | |
| | | | CONDO DATA | | |
| | | | Parcel Id | C | Owne 0.0 |
| | | | | B | S |
| | | | Adjust Type | Code | Description |
| | | | Condo Flr | | Factor% |
| | | | Condo Unit | | |
| | | | COST / MARKET VALUATION | | |
| | | | Building Value New | | 690,968 |
| | | | Year Built | | 1971 |
| | | | Effective Year Built | | 1991 |
| | | | Depreciation Code | | A |
| | | | Remodel Rating | | |
| | | | Year Remodeled | | |
| | | | Depreciation % | | 22 |
| | | | Functional Obsol | | 0 |
| | | | External Obsol | | 0 |
| | | | Trend Factor | | 1 |
| | | | Condition | | |
| | | | Condition % | | |
| | | | Percent Good | | 78 |
| | | | RCNLD | | 539,000 |
| | | | Dep % Ovr | | |
| | | | Dep Ovr Comment | | |
| | | | Misc Imp Ovr | | |
| | | | Misc Imp Ovr Comment | | |
| | | | Cost to Cure Ovr | | |
| | | | Cost to Cure Ovr Comment | | |

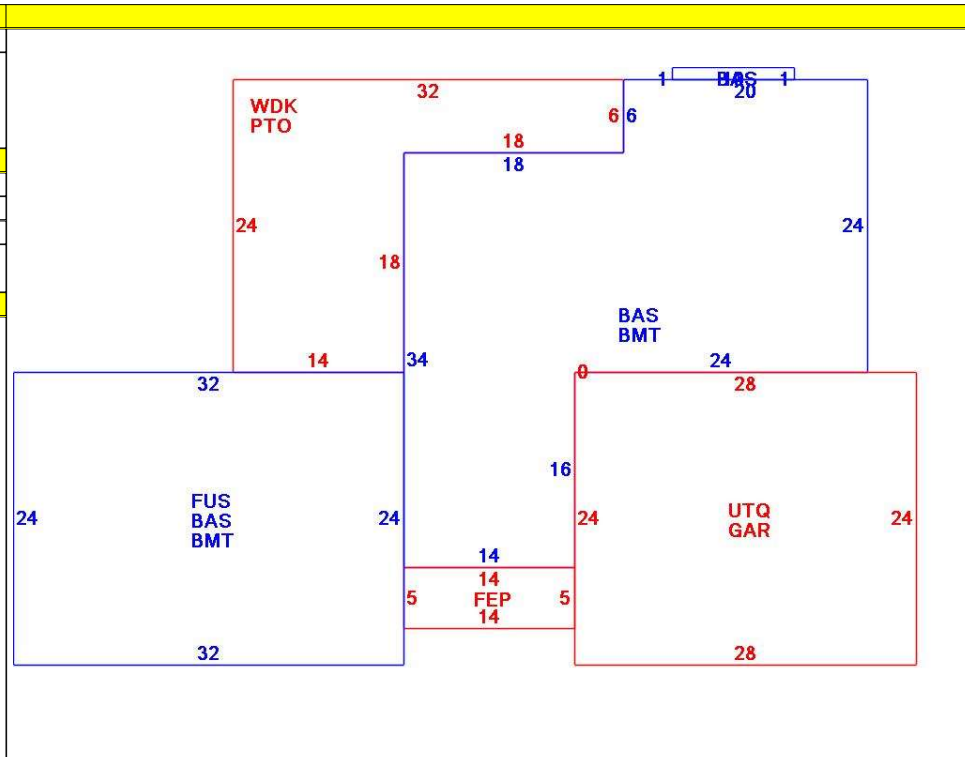

| OB - OUTBUILDING & YARD ITEMS(L) / XF - BUILDING EXTRA FEATURES(B) | | | | | | | | | | |
|--|-----------------|-----|-------|------------|--------|----------|------|-------|------------|-------------|
| Code | Description | L/B | Units | Unit Price | Yr Blt | Cond. Cd | % Gd | Grade | Grade Adj. | Appr. Value |
| FPL3 | Fireplace 2 sto | B | 1 | 7000.00 | 1993 | | 78 | | 0.00 | 5,500 |
| WDC | Wood Decking | L | 444 | 20.00 | 1996 | | 54 | | 0.00 | 4,600 |
| PAT2 | Patio-Good | L | 444 | 9.94 | 1996 | | 77 | | 0.00 | 3,300 |
| FEP | Enclosed porc | B | 70 | 70.00 | 1993 | | 78 | | 0.00 | 5,200 |
| GAR | Attached Gara | B | 672 | 40.00 | 1993 | | 78 | | 0.00 | 17,800 |
| BMT | Basement-Unfi | B | 1,796 | 26.01 | 1993 | | 78 | | 0.00 | 31,900 |

| BUILDING SUB-AREA SUMMARY SECTION | | | | | | |
|-----------------------------------|--------------------------------|-------------|------------|----------|-----------|----------------|
| Code | Description | Living Area | Floor Area | Eff Area | Unit Cost | Undeprec Value |
| BAS | First Floor | 1,806 | 1,806 | 1,806 | 237.45 | 428,827 |
| BMT | Basement Area | 0 | 1,796 | 0 | 0.00 | 0 |
| FEP | Enclosed Porch | 0 | 70 | 0 | 0.00 | 0 |
| FUS | Upper Story | 768 | 768 | 768 | 237.45 | 182,359 |
| GAR | Attached Garage | 0 | 672 | 0 | 0.00 | 0 |
| PTO | Patio | 0 | 444 | 0 | 0.00 | 0 |
| UTQ | Unfinished Three-quarter story | 0 | 672 | 336 | 118.72 | 79,782 |
| WDK | Wood Deck | 0 | 444 | 0 | 0.00 | 0 |
| Ttl Gross Liv / Lease Area | | 2,574 | 6,672 | 2,910 | | 690,968 |

