

| CURRENT OWNER | | TOPO | | UTILITIES | | STRT / ROAD | | LOCATION | | CURRENT ASSESSMENT | | | | 801 FY2024 BARNSTABLE, MA VISION | | | | | | | |
|---|------------|--------------------------|---------------|-------------------|--------------|-------------|------------------------|-------------------------|------------|-------------------------------|-------|---|------------------|--|--------------------|--------------------------------|-----------------------|--------------------|--------------------|---------|----------|
| TAMBASCIA, ANTHONY D JR & REBE 47 OAKMONT RD CUMMAQUID MA 02637 | | 2 | Above Street | 2 | Public Water | 1 | Paved | | | Description | Code | Assessed | Assessed | | | RESIDNTL RES LAND | 1010 1010 | 493,200 199,000 | 493,200 199,000 | | |
| | | 4 | Gas | | | | | | | | | | | | | | | | | | |
| | | 6 | Septic | | | | | | | | | | | | | | | | | | |
| SUPPLEMENTAL DATA | | | | | | | | | | Total | | 692,200 | 692,200 | | | | | | | | |
| Alt Prcl ID | | Split Zonin | | Plan Ref. | | 235/149 | | | | | | | | | | | | | | | |
| BID Parcel | | ResExpt Q | | INFO: | | Life Estate | | PP STATU | | | | | | | | | | | | | |
| #DL 1 | | LOT 208 | | | | | | | | | | | | | | | | | | | |
| #DL 2 | | | | | | | | | | | | | | | | | | | | | |
| GIS ID | | F_992764_2714993 | | Assoc Pid# | | | | | | | | | | | | | | | | | |
| RECORD OF OWNERSHIP | | | | BK-VOL/PAGE | | SALE DATE | | Q/U | | V/I | | SALE PRIC | | VC | | PREVIOUS ASSESSMENTS (HISTORY) | | | | | |
| TAMBASCIA, ANTHONY D JR & REBECC | | | | 21852 | 0328 | 03-15-2007 | U | I | 452,500 | 1 | | | Year | Code | Assessed | Year | Code | Assessed V | Year | Code | Assessed |
| CARTUS FINANCIAL CORP | | | | 21852 | 0326 | 03-15-2007 | Q | I | 452,500 | 00 | | | 2023 | 1010 | 440,800 | 2022 | 1010 | 380,000 | 2021 | 1010 | 296,500 |
| RYAN, MICHAEL PETER & | | | | 17771 | 0234 | 10-08-2003 | U | I | 1 | 1A | | | | 1010 | 196,700 | | 1010 | 139,900 | | 1010 | 139,900 |
| RYAN, MICHAEL PETER | | | | 17387 | 0343 | 08-01-2003 | Q | I | 416,000 | 00 | | | | | | | | | | 1010 | 36,600 |
| STERGIS, JAMES K & MARY V | | | | 9467 | 0166 | 12-02-1994 | Q | I | 194,000 | 00 | | | | | | | | | | | |
| | | | | Total | | | | | | | | Total | | 637,500 | Total | | 519,900 | Total | | 473,000 | |
| EXEMPTIONS | | | | OTHER ASSESSMENTS | | | | | | | | This signature acknowledges a visit by a Data Collector or Assessor | | | | | | | | | |
| Year | Code | Description | | Amount | | Code | Description | | Number | Amount | | Comm Int | | | | | | | | | |
| 2024 | N5C | NO RESIDENTIAL EXEMPTION | | | | | | | | | | | | | | | | | | | |
| | | | | Total | | 0.00 | | | | | | | | | | | | | | | |
| ASSESSING NEIGHBORHOOD | | | | | | | | | | | | APPRAISED VALUE SUMMARY | | | | | | | | | |
| Nbhd | | Nbhd Name | | B | | Tracing | | Batch | | Appraised Bldg. Value (Card) | | | | 406,900 | | | | | | | |
| 0107 | | | | | | | | BARNs | | Appraised Xf (B) Value (Bldg) | | | | 49,300 | | | | | | | |
| | | | | | | | | | | Appraised Ob (B) Value (Bldg) | | | | 37,000 | | | | | | | |
| | | | | | | | | | | Appraised Land Value (Bldg) | | | | 199,000 | | | | | | | |
| | | | | | | | | | | Special Land Value | | | | 0 | | | | | | | |
| | | | | | | | | | | Total Appraised Parcel Value | | | | 692,200 | | | | | | | |
| | | | | | | | | | | Valuation Method | | | | C | | | | | | | |
| | | | | | | | | | | Total Appraised Parcel Value | | | | 692,200 | | | | | | | |
| BUILDING PERMIT RECORD | | | | | | | | | | | | VISIT / CHANGE HISTORY | | | | | | | | | |
| Permit Id | Issue Date | Type | Description | Amount | Insp Date | % Comp | Date Comp | Comments | | | | Date | Id | Type | Is | Cd | Purpost/Result | | | | |
| 201307658 | 12-27-2013 | SP | Swimming Pool | 28,000 | 05-01-2014 | 100 | 06-30-2014 | POOL 18X36 W FNC-NOT HE | | | | 04-05-2023 | DB | 02 | | 03 | Cycl Insp Comp | | | | |
| B29757 | 08-01-1986 | DW | Dwelling | 110,000 | 01-15-1988 | 100 | 01-15-1988 | BA 11/2 S | | | | 05-04-2020 | DM | | | FR | Field Review | | | | |
| | | | | | | | | | | | | 03-24-2015 | SR | 02 | | 03 | Cycl Insp Comp | | | | |
| | | | | | | | | | | | | 01-15-2015 | MW | 02 | | 02 | Bldg Permit Completed | | | | |
| | | | | | | | | | | | | 05-21-2014 | MW | 02 | | 13 | CALL BACK | | | | |
| LAND LINE VALUATION SECTION | | | | | | | | | | | | | | | | | | | | | |
| B | Use Code | Description | Zone | LA | Land Units | Unit Price | Size Adj | AC Disc | Site Index | Cond. | Nbhd. | Nbhd. Adj | Notes | | Location Adjustmen | | Adj Unit P | Land Value | | | |
| 1 | 1010 | Single Fam M-0 | RF-1 | 1 | 0.800 | AC | 176,344.00 | 1.22679 | 1.0000 | 5 | 1.00 | 0106 | 1.150 | | | 1.0000 | 248,786.1 | 199,000 | | | |
| Total Card Land Units | | | | | 0.80 | AC | Parcel Total Land Area | | | | | 0.80 | Total Land Value | | | | | 199,000 | | | |

| CONSTRUCTION DETAIL | | | CONSTRUCTION DETAIL (CONTINUED) | | |
|---------------------|------|----------------|---------------------------------|----|-------------|
| Element | Cd | Description | Element | Cd | Description |
| Style | 04 | Cape Cod | | | |
| Model | 01 | Residential | | | |
| Grade: | C | Average | | | |
| Stories | 1.66 | | | | |
| Exterior Wall 1 | 14 | Wood Shingle | | | |
| Exterior Wall 2 | 11 | Clapboard | | | |
| Roof Structure | 03 | Gable/Hip | | | |
| Roof Cover | 03 | Asph/F Gls/Cmp | | | |
| Interior Wall 1 | 05 | Drywall | | | |
| Interior Wall 2 | | | | | |
| Interior Floor 1 | 14 | Carpet | | | |
| Interior Floor 2 | 12 | Hardwood | | | |
| Heat Fuel | 03 | Gas | | | |
| Heat Type | 05 | Hot Water | | | |
| AC Type | 01 | None | | | |
| Bedrooms | 04 | 4 Bedrooms | | | |
| Full Baths | 2 | | | | |
| Half Baths | 1 | | | | |
| Extra Fixtures | | | | | |
| Total Rooms | 8 | 8 Rooms | | | |
| Bath Style | | | | | |
| Kitchen Style | | | | | |
| Occupancy | | | | | |
| Usrflid 105 | | | | | |
| Accessory Apt | | | | | |
| Foundation Alt | 01 | Poured Conc. | | | |
| Rms Prts | | | | | |
| Bath Split | 21 | 2 Full-1 Half | | | |

| CONDO DATA | | | |
|-------------|------|-------------|----------|
| Parcel Id | | C | Owne 0.0 |
| | | B | S |
| Adjust Type | Code | Description | Factor% |
| Condo Flr | | | |
| Condo Unit | | | |

| COST / MARKET VALUATION | |
|--------------------------|---------|
| Building Value New | 484,456 |
| Year Built | 1986 |
| Effective Year Built | 1999 |
| Depreciation Code | A |
| Remodel Rating | |
| Year Remodeled | |
| Depreciation % | 16 |
| Functional Obsol | 0 |
| External Obsol | 0 |
| Trend Factor | 1 |
| Condition | |
| Condition % | |
| Percent Good | 84 |
| RCNLD | 406,900 |
| Dep % Ovr | |
| Dep Ovr Comment | |
| Misc Imp Ovr | |
| Misc Imp Ovr Comment | |
| Cost to Cure Ovr | |
| Cost to Cure Ovr Comment | |

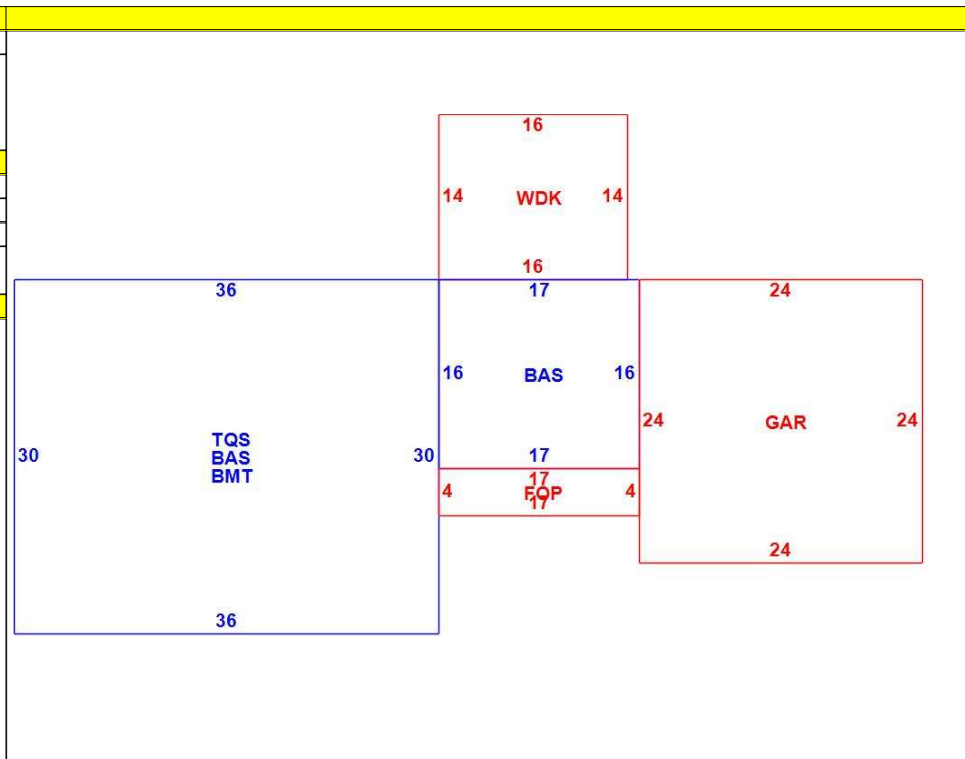

| OB - OUTBUILDING & YARD ITEMS(L) / XF - BUILDING EXTRA FEATURES(B) | | | | | | | | | | |
|--|-----------------|-----|-------|------------|--------|----------|------|-------|------------|-------------|
| Code | Description | L/B | Units | Unit Price | Yr Blt | Cond. Cd | % Gd | Grade | Grade Adj. | Appr. Value |
| FPL2 | Fireplace 1.5 s | B | 1 | 6000.00 | 2001 | | 84 | | 0.00 | 5,000 |
| WDC | Wood Deck w/ | L | 224 | 18.00 | 1999 | | 60 | | 0.00 | 2,700 |
| FOP | Open Porch-ro | B | 68 | 55.00 | 2001 | | 84 | | 0.00 | 3,600 |
| GAR | Attached Gara | B | 576 | 40.00 | 2001 | | 84 | | 0.00 | 17,200 |
| BMT | Basement-Unfi | B | 1,080 | 26.01 | 2001 | | 84 | | 0.00 | 23,500 |
| SPL2 | Pool Vinyl | L | 648 | 55.00 | 2013 | | 88 | 00 | 1.00 | 30,100 |
| PAT1 | Patio- Average | L | 736 | 5.89 | 2013 | | 94 | | 0.00 | 3,800 |
| SPDS | POOL DK CO | L | 736 | 0.56 | 2013 | | 94 | | 0.00 | 400 |

| BUILDING SUB-AREA SUMMARY SECTION | | | | | | |
|-----------------------------------|---------------------|-------------|------------|----------|-----------|----------------|
| Code | Description | Living Area | Floor Area | Eff Area | Unit Cost | Undeprec Value |
| BAS | First Floor | 1,352 | 1,352 | 1,352 | 235.86 | 318,883 |
| BMT | Basement Area | 0 | 1,080 | 0 | 0.00 | 0 |
| FOP | Open Porch | 0 | 68 | 0 | 0.00 | 0 |
| GAR | Attached Garage | 0 | 576 | 0 | 0.00 | 0 |
| TQS | Three Quarter Story | 702 | 1,080 | 702 | 153.31 | 165,574 |
| WDK | Wood Deck | 0 | 224 | 0 | 0.00 | 0 |
| Ttl Gross Liv / Lease Area | | 2,054 | 4,380 | 2,054 | | 484,457 |

