

| CURRENT OWNER | | TOPO | UTILITIES | STRT / ROAD | LOCATION | CURRENT ASSESSMENT | | | |
|---|--|---------|----------------|--|----------|-----------------------|------|----------|----------|
| RICHARDS, KEITH C & LYNN S 84 MARSTONS LN YARMOUTH PO MA 02675 | | 1 Level | 2 Public Water | 1 Paved | | Description | Code | Assessed | Assessed |
| | | | 4 Gas | | | RESIDNTL | 1010 | 519,000 | 519,000 |
| | | | 6 Septic | | | RES LAND | 1010 | 228,000 | 228,000 |
| SUPPLEMENTAL DATA | | | | | | Total 747,000 747,000 | | | |
| Alt Prcl ID Split Zonin BID Parcel ResExpt Q YES: #DL 1 LOT 1 #DL 2 GIS ID F_993683_2717728 | | | | Plan Ref. 190/29 Land Ct# #SR Life Estate PP STATU Assoc Pid# | | | | | |

801
 FY2024
 BARNSTABLE, MA
VISION

| RECORD OF OWNERSHIP | | BK-VOL/PAGE | SALE DATE | Q/U | V/I | SALE PRIC | VC | PREVIOUS ASSESSMENTS (HISTORY) | | | | | |
|----------------------------|--|-------------|------------|-----|-----|-----------|----|--------------------------------|------|----------|-------|------|----------|
| RICHARDS, KEITH C & LYNN S | | 11169 0143 | 01-15-1998 | U | I | 1 | 1A | Year | Code | Assessed | Year | Code | Assessed |
| RICHARDS, KEITH C & LYNN S | | 7311 0224 | 10-15-1990 | U | I | 100 | A | 2023 | 1010 | 462,000 | 2022 | 1010 | 390,200 |
| RICHARDS, KEITH C & LYNN S | | 2482 0180 | 03-22-1977 | U | | 0 | | | 1010 | 207,300 | 2021 | 1010 | 142,600 |
| | | | | | | | | Total | | 669,300 | Total | | 532,800 |
| | | | | | | | | Total | | | Total | | 483,900 |

| EXEMPTIONS | | | | OTHER ASSESSMENTS | | | |
|------------|------|-----------------------|--------|-------------------|-------------|--------|--------|
| Year | Code | Description | Amount | Code | Description | Number | Amount |
| 2010 | 5C | RESIDENTIAL EXEMPTION | 0.00 | | | | |
| Total | | | 0.00 | | | | |

This signature acknowledges a visit by a Data Collector or Assessor

| ASSESSING NEIGHBORHOOD | | | |
|------------------------|-----------|---|---------|
| Nbhd | Nbhd Name | B | Tracing |
| 0107 | | | BARNS |

| APPRAISED VALUE SUMMARY | |
|-------------------------------|---------|
| Appraised Bldg. Value (Card) | 450,800 |
| Appraised Xf (B) Value (Bldg) | 61,500 |
| Appraised Ob (B) Value (Bldg) | 6,700 |
| Appraised Land Value (Bldg) | 228,000 |
| Special Land Value | 0 |
| Total Appraised Parcel Value | 747,000 |
| Valuation Method | C |
| Total Appraised Parcel Value | 747,000 |

| NOTES | | | | | | | |
|-------|--|--|--|--|--|--|--|
| | | | | | | | |

| BUILDING PERMIT RECORD | | | | | | | | | VISIT / CHANGE HISTORY | | | | | |
|------------------------|------------|------|--------------|--------|------------|--------|------------|--------------------------------|------------------------|----|------|----|----|----------------------------|
| Permit Id | Issue Date | Type | Description | Amount | Insp Date | % Comp | Date Comp | Comments | Date | Id | Type | Is | Cd | Purpost/Result |
| 19-2683 | 08-21-2019 | 804 | Addn Alt-Res | 42,000 | 06-30-2020 | 100 | 06-30-2020 | Re-roof and reside entire hous | 04-10-2023 | DB | 02 | | 03 | Cycl Insp Comp |
| 201400105 | 01-22-2014 | RE | Remodel | 12,000 | 03-20-2014 | 100 | 06-30-2014 | REMOD 1ST FLR BTH | 05-04-2020 | DM | | | FR | Field Review |
| 201305049 | 07-29-2013 | GN | Generator | 0 | 03-20-2014 | 100 | 06-30-2014 | GEN | 03-18-2015 | SR | 01 | | 03 | Cycl Insp Comp |
| 65110 | 11-05-2002 | NR | New Roof | 8,000 | 01-09-2003 | 100 | 01-01-2003 | | 03-28-2014 | MW | 01 | | 02 | Bldg Permit Completed |
| B30544 | 03-01-1987 | AD | Addition | 15,600 | 01-15-1988 | 100 | 01-15-1988 | BA ADD'N | 01-09-2003 | MF | 04 | | 44 | Drive by inspection only |
| B23513 | 09-01-1981 | AD | Addition | 0 | 01-15-1982 | 100 | 01-15-1982 | BA ADD'N | 09-23-2000 | PT | 01 | | 00 | Meas/Listed-Interior Acces |
| B17721 | 06-01-1975 | DW | Dwelling | 0 | 01-15-1976 | 100 | 01-15-1976 | BA 2 STOR | 06-15-1993 | ME | 02 | | 01 | Meas/Est |

| LAND LINE VALUATION SECTION | | | | | | | | | | | | | | | | |
|-----------------------------|----------|----------------|------|----|------------|------------|----------|---------|------------|-------|-------|-----------|-------|--------------------|------------|------------|
| B | Use Code | Description | Zone | LA | Land Units | Unit Price | Size Adj | AC Disc | Site Index | Cond. | Nbhd. | Nbhd. Adj | Notes | Location Adjustmen | Adj Unit P | Land Value |
| 1 | 1010 | Single Fam M-0 | RF-2 | 1 | 0.570 AC | 176,344.00 | 1.62049 | 1.0000 | 5 | 1.00 | 0107 | 1.400 | | 1.0000 | 400,071.6 | 228,000 |

| CONSTRUCTION DETAIL | | | CONSTRUCTION DETAIL (CONTINUED) | | |
|---------------------|------|----------------|---------------------------------|----|-------------|
| Element | Cd | Description | Element | Cd | Description |
| Style | 04 | Cape Cod | | | |
| Model | 01 | Residential | | | |
| Grade: | C | Average | | | |
| Stories | 1.66 | | | | |
| Exterior Wall 1 | 14 | Wood Shingle | | | |
| Exterior Wall 2 | | | | | |
| RooF Structure | 03 | Gable/Hip | | | |
| RooF Cover | 03 | Asph/F Gls/Cmp | | | |
| Interior Wall 1 | 05 | Drywall | | | |
| Interior Wall 2 | | | | | |
| Interior Floor 1 | 12 | Hardwood | | | |
| Interior Floor 2 | | | | | |
| Heat Fuel | 03 | Gas | | | |
| Heat Type | 05 | Hot Water | | | |
| AC Type | 01 | None | | | |
| Bedrooms | 03 | 3 Bedrooms | | | |
| Full Baths | 2 | | | | |
| Half Baths | 0 | | | | |
| Extra Fixtures | | | | | |
| Total Rooms | 7 | 7 Rooms | | | |
| Bath Style | | | | | |
| Kitchen Style | | | | | |
| Occupancy | | | | | |
| Usrflid 105 | | | | | |
| Accessory Apt | | | | | |
| Foundation Alt | 08 | Mixed | | | |
| Rms Prts | | | | | |
| Bath Split | 20 | 2 Full-0 Half | | | |

| CONDO DATA | | | | |
|-------------|------|-------------|---------|-----|
| Parcel Id | | C | Owne | 0.0 |
| Adjust Type | Code | Description | Factor% | |
| Condo Fir | | | | |
| Condo Unit | | | | |

| COST / MARKET VALUATION | |
|--------------------------|---------|
| Building Value New | 536,653 |
| Year Built | 1975 |
| Effective Year Built | 1998 |
| Depreciation Code | G |
| Remodel Rating | |
| Year Remodeled | |
| Depreciation % | 16 |
| Functional Obsol | 0 |
| External Obsol | 0 |
| Trend Factor | 1 |
| Condition | |
| Condition % | |
| Percent Good | 84 |
| RCNLD | 450,800 |
| Dep % Ovr | |
| Dep Ovr Comment | |
| Misc Imp Ovr | |
| Misc Imp Ovr Comment | |
| Cost to Cure Ovr | |
| Cost to Cure Ovr Comment | |

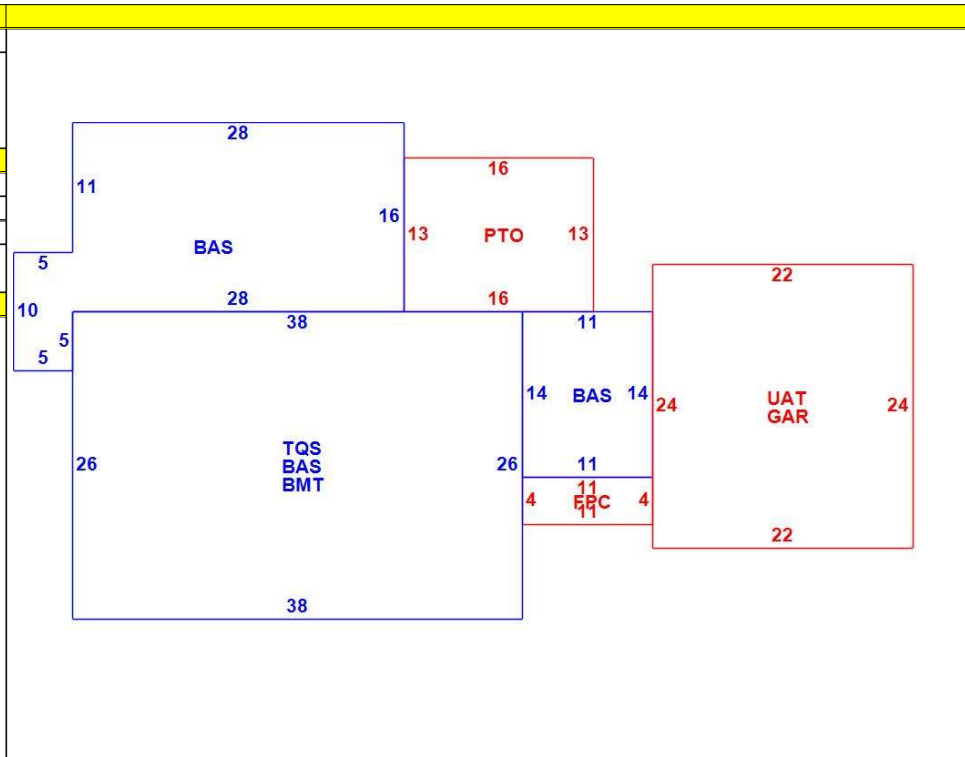

| OB - OUTBUILDING & YARD ITEMS(L) / XF - BUILDING EXTRA FEATURES(B) | | | | | | | | | | |
|--|-----------------|-----|-------|------------|--------|----------|------|-------|------------|-------------|
| Code | Description | L/B | Units | Unit Price | Yr Blt | Cond. Cd | % Gd | Grade | Grade Adj. | Appr. Value |
| FPL2 | Fireplace 1.5 s | B | 1 | 6000.00 | 2000 | | 84 | | 0.00 | 5,000 |
| PAT2 | Patio-Good | L | 208 | 9.94 | 1997 | | 78 | | 0.00 | 1,800 |
| FOPC | Open Prch-roo | B | 44 | 55.00 | 2000 | | 84 | | 0.00 | 2,200 |
| GAR | Attached Gara | B | 528 | 40.00 | 2000 | | 84 | | 0.00 | 16,200 |
| BMT | Basement-Unfi | B | 988 | 26.01 | 2000 | | 84 | | 0.00 | 22,100 |
| FPL1 | Fireplace 1 sto | B | 1 | 5000.00 | 2000 | | 84 | | 0.00 | 4,200 |
| GEN | Emergency Ge | L | 1 | 5550.00 | 2013 | | 88 | | 0.00 | 4,900 |
| FPLG | Gas Fireplace- | B | 2 | 2500.00 | 2000 | | 84 | | 0.00 | 4,200 |
| BFA | Bsmt Fin-Avg | B | 520 | 17.36 | 2000 | | 84 | | 0.00 | 7,600 |

| BUILDING SUB-AREA SUMMARY SECTION | | | | | | |
|-----------------------------------|------------------------|-------------|------------|----------|-----------|----------------|
| Code | Description | Living Area | Floor Area | Eff Area | Unit Cost | Undeprec Value |
| BAS | First Floor | 1,640 | 1,640 | 1,640 | 229.83 | 376,921 |
| BMT | Basement Area | 0 | 988 | 0 | 0.00 | 0 |
| FPC | Open Porch Conc. Floor | 0 | 44 | 0 | 0.00 | 0 |
| GAR | Attached Garage | 0 | 528 | 0 | 0.00 | 0 |
| PTO | Patio | 0 | 208 | 0 | 0.00 | 0 |
| TQS | Three Quarter Story | 642 | 988 | 642 | 149.34 | 147,551 |
| UAT | Attic, Unfinished | 0 | 528 | 53 | 23.07 | 12,181 |
| Ttl Gross Liv / Lease Area | | 2,282 | 4,924 | 2,335 | | 536,653 |

