

CURRENT OWNER		TOPO	UTILITIES	STRT / ROAD	LOCATION	CURRENT ASSESSMENT			
KENT, JOHN B & NATHALIE S TRS KENT FAMILY TRUST PO BOX 147  CUMMAQUID MA 02637		1 Level	2 Public Water	1 Paved		Description	Code	Assessed	Assessed
			4 Gas			RESIDNTL	1010	489,200	489,200
			6 Septic			RES LAND	1010	299,200	299,200
<b>SUPPLEMENTAL DATA</b>									
Alt Prcl ID		Split Zonin		Plan Ref. 17/103					
BID Parcel		ResExpt Q		Land Ct#					
#DL 1		INFO: PARCEL 1		#SR					
#DL 2				Life Estate					
GIS ID F_991801_2718812				PP STATU					
				Assoc Pid#					
						Total	788,400	788,400	

801  
 FY2024  
 BARNSTABLE, MA  
**VISION**

RECORD OF OWNERSHIP		BK-VOL/PAGE	SALE DATE	Q/U	V/I	SALE PRIC	VC	PREVIOUS ASSESSMENTS (HISTORY)					
KENT, JOHN B & NATHALIE S TRS		34556 180	10-08-2021	U	I	1	1F	Year	Code	Assessed	Year	Code	Assessed
KENT, JOHN B & NATHALIE S		14208 0086	09-06-2001	Q	I	400,000	1	2023	1010	436,400	2022	1010	362,100
SHACKELFORD, LEO F & AUDREY E		12461 0251	08-09-1999	U	I	383,000	1		1010	296,000	2021	1010	189,600
HEGARTY, JAMES W & BRENDA D		2644 0026	01-04-1978	U		0						1010	7,000
						Total		732,400	Total		551,700	Total	506,400

EXEMPTIONS		OTHER ASSESSMENTS						
Year	Code	Description	Amount	Code	Description	Number	Amount	Comm Int
2023	N5C	NO RESIDENTIAL EXEMPTION	0.00					
		Total	0.00					

This signature acknowledges a visit by a Data Collector or Assessor

ASSESSING NEIGHBORHOOD			
Nbhd	Nbhd Name	B	Tracing
0108			BARNS

APPRAISED VALUE SUMMARY	
Appraised Bldg. Value (Card)	461,000
Appraised Xf (B) Value (Bldg)	21,200
Appraised Ob (B) Value (Bldg)	7,000
Appraised Land Value (Bldg)	299,200
Special Land Value	0
Total Appraised Parcel Value	788,400
Valuation Method	C
Total Appraised Parcel Value	788,400

NOTES							

BUILDING PERMIT RECORD								VISIT / CHANGE HISTORY						
Permit Id	Issue Date	Type	Description	Amount	Insp Date	% Comp	Date Comp	Comments	Date	Id	Type	Is	Cd	Purpost/Result
B27444	01-02-1985	AD	Addition	70,000	01-15-1986	100	06-30-1986	BA 900SQF	05-04-2020	DM			FR	Field Review
									08-10-2015	SR	02		03	Cycl Insp Comp
									01-08-2015	JR	03		16	In Office Review

LAND LINE VALUATION SECTION																
B	Use Code	Description	Zone	LA	Land Units	Unit Price	Size Adj	AC Disc	Site Index	Cond.	Nbhd.	Nbhd. Adj	Notes	Location Adjustmen	Adj Unit P	Land Value
1	1010	Single Fam M-0	RF-2	1	0.980 AC	176,344.00	1.01851	1.0000	5	1.00	0108	1.700	SOLD WITH 350-50		1.0000	305,339.6
Total Card Land Units					0.98 AC	Parcel Total Land Area					0.98	Total Land Value				299,200

CONSTRUCTION DETAIL			CONSTRUCTION DETAIL (CONTINUED)		
Element	Cd	Description	Element	Cd	Description
Style	04	Cape Cod			
Model	01	Residential			
Grade:	C+	Average Plus			
Stories	1.4				
Exterior Wall 1	11	Clapboard			
Exterior Wall 2	14	Wood Shingle			
Roof Structure	03	Gable/Hip			
Roof Cover	03	Asph/F Gls/Cmp			
Interior Wall 1	05	Drywall			
Interior Wall 2					
Interior Floor 1	12	Hardwood			
Interior Floor 2	14	Carpet			
Heat Fuel	03	Gas			
Heat Type	05	Hot Water			
AC Type	01	None			
Bedrooms	03	3 Bedrooms			
Full Baths	3				
Half Baths	0				
Extra Fixtures					
Total Rooms	10	10 Rooms			
Bath Style					
Kitchen Style					
Occupancy	1				
Usrflid 105					
Accessory Apt					
Foundation Alt	11	Stone Ftgs			
Rms Prts					
Bath Split	30	3 Full-0 Half			

CONDO DATA				
Parcel Id		C	Ownr	0.0
			B	S
Adjust Type	Code	Description	Factor%	
Condo Flr				
Condo Unit				

COST / MARKET VALUATION	
Building Value New	606,517
Year Built	1965
Effective Year Built	1988
Depreciation Code	A
Remodel Rating	
Year Remodeled	
Depreciation %	24
Functional Obsol	0
External Obsol	0
Trend Factor	1
Condition	
Condition %	
Percent Good	76
RCNLD	461,000
Dep % Ovr	
Dep Ovr Comment	
Misc Imp Ovr	
Misc Imp Ovr Comment	
Cost to Cure Ovr	
Cost to Cure Ovr Comment	

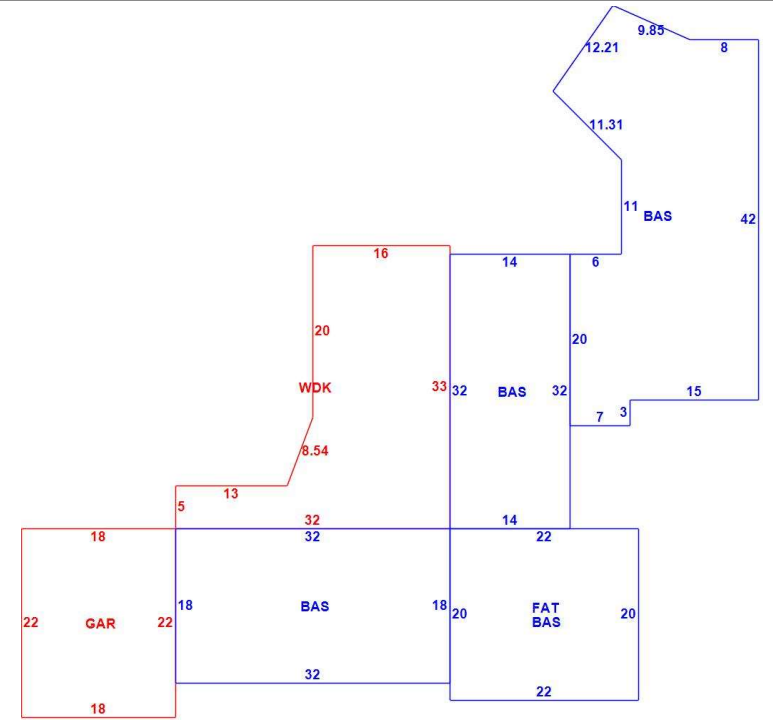

OB - OUTBUILDING & YARD ITEMS(L) / XF - BUILDING EXTRA FEATURES(B)										
Code	Description	L/B	Units	Unit Price	Yr Blt	Cond. Cd	% Gd	Grade	Grade Adj.	Appr. Value
FPL2	Fireplace 1.5 s	B	2	6000.00	1990		76		0.00	9,100
SHED	Shed	L	168	18.00	1990		42		0.00	1,300
WDC	Wood Decking	L	620	20.00	1994		50		0.00	5,700
GAR	Attached Gara	B	396	40.00	1990		76		0.00	12,100

BUILDING SUB-AREA SUMMARY SECTION						
Code	Description	Living Area	Floor Area	Eff Area	Unit Cost	Undeprec Value
BAS	First Floor	2,350	2,350	2,350	251.04	589,949
FAT	Attic, Finished	66	440	66	37.66	16,569
GAR	Attached Garage	0	396	0	0.00	0
WDK	Wood Deck	0	620	0	0.00	0
Ttl Gross Liv / Lease Area		2,416	3,806	2,416		606,518

