

| CURRENT OWNER | | TOPO | UTILITIES | STRT / ROAD | LOCATION | CURRENT ASSESSMENT | | | | 801 FY2024 BARNSTABLE, MA VISION |
|--|--|---------|---|-------------|-----------------|-------------------------------------|----------------------|------------------------------------|------------------------------------|--|
| HANS, GAYLE B PO BOX 445 CUMMAQUID MA 02637 | | 1 Level | 2 Public Water | 3 Unpaved | 1 Excel View | Description RESIDNTL RES LAND | Code 1010 1010 | Assessed 3,129,500 2,293,400 | Assessed 3,129,500 2,293,400 | |
| | | | 4 Gas | | 9 Rear Location | | | | | |
| | | | | | 6 Septic | | | Total 5,422,900 5,422,900 | | |
| SUPPLEMENTAL DATA | | | | | | | | | | |
| Alt Prcl ID Split Zonin BID Parcel ResExpt Q #DL 1 #DL 2 GIS ID F_992724_2720825 | | | Plan Ref. Land Ct# #SR Life Estate PP STATU Assoc Pid# | | | | | | | |

| RECORD OF OWNERSHIP | | BK-VOL/PAGE | SALE DATE | Q/U | V/I | SALE PRIC | VC | PREVIOUS ASSESSMENTS (HISTORY) | | | | | | | | | |
|-----------------------------------|--|-------------|-----------|------------|-----|-----------|-----------|--------------------------------|-------|------|-----------|-------|------|-----------|-------|------|-----------|
| HANS, GAYLE B | | 28938 | 0322 | 06-15-2015 | Q | I | 3,500,000 | 00 | Year | Code | Assessed | Year | Code | Assessed | Year | Code | Assessed |
| EVANKO, JOHN & JENNIFER | | 24345 | 0238 | 02-02-2010 | U | I | 3,750,000 | 1 | 2023 | 1010 | 2,686,200 | 2022 | 1010 | 2,237,900 | 2021 | 1010 | 1,840,000 |
| TURNBULL, JEAN & MYERS, PRISCILLA | | 13018 | 0223 | 05-19-2000 | Q | I | 1,550,000 | 00 | | 1010 | 1,841,800 | | 1010 | 2,139,900 | | 1010 | 1,762,300 |
| BERNSTEIN, ARTHUR M & ELAINE C | | 3352 | 0102 | 08-31-1981 | U | | 0 | | Total | | 4,528,000 | Total | | 4,377,800 | Total | | 3,821,300 |

| EXEMPTIONS | | | OTHER ASSESSMENTS | | | | | This signature acknowledges a visit by a Data Collector or Assessor | | | | | | | | | | |
|------------|------|-------------|-------------------|------|-------------|--------|--------|---|--|--|--|--|--|--|--|--|--|--|
| Year | Code | Description | Amount | Code | Description | Number | Amount | Comm Int | | | | | | | | | | |
| Total | | | 0.00 | | | | | | | | | | | | | | | |

| ASSESSING NEIGHBORHOOD | | | | | APPRAISED VALUE SUMMARY | | | | | |
|------------------------|-----------|---|---------|-------|-------------------------------|--|--|--|--|-----------|
| Nbhd | Nbhd Name | B | Tracing | Batch | Appraised Bldg. Value (Card) | | | | | 2,739,100 |
| 0120 | | | | BARNS | Appraised Xf (B) Value (Bldg) | | | | | 171,400 |
| | | | | | Appraised Ob (B) Value (Bldg) | | | | | 219,000 |
| | | | | | Appraised Land Value (Bldg) | | | | | 2,293,400 |
| | | | | | Special Land Value | | | | | 0 |
| | | | | | Total Appraised Parcel Value | | | | | 5,422,900 |
| | | | | | Valuation Method | | | | | C |
| | | | | | Total Appraised Parcel Value | | | | | 5,422,900 |

| BUILDING PERMIT RECORD | | | | | | | | | | VISIT / CHANGE HISTORY | | | | | |
|------------------------|------------|------|----------------|---------|------------|--------|------------|------------------------|------------|------------------------|------|----|----|-----------------------|--|
| Permit Id | Issue Date | Type | Description | Amount | Insp Date | % Comp | Date Comp | Comments | Date | Id | Type | Is | Cd | Purpost/Result | |
| 201001120 | 03-23-2010 | RE | Remodel | 175,000 | 07-23-2010 | 100 | 06-30-2011 | FIN OVER GAR;EXTEND RE | 07-07-2023 | WT | 02 | | 03 | Cycl Insp Comp | |
| 80410 | 10-26-2004 | RE | Remodel | 147,840 | 12-11-2006 | 100 | 06-30-2007 | | 05-04-2020 | DM | | | FR | Field Review | |
| 66254 | 01-07-2003 | RA | Remodel-Additi | 61,444 | 01-22-2004 | 100 | 01-01-2004 | | 03-30-2016 | AL | 22 | | 22 | Change of Address | |
| 64169 | 10-02-2002 | SP | Swimming Pool | 60,000 | 01-22-2004 | 100 | 01-01-2004 | | 03-16-2016 | SR | 01 | | 03 | Cycl Insp Comp | |
| 64049 | 09-26-2002 | AD | Addition | 150,000 | 01-22-2004 | 100 | 01-01-2004 | | 02-21-2012 | RB | 03 | | 16 | In Office Review | |
| B34948 | 04-01-1992 | AD | Addition | 8,000 | 01-15-1993 | 100 | 06-30-1993 | BA REMODE | 01-20-2011 | NF | 03 | | 02 | Bldg Permit Completed | |
| B30699 | 05-01-1987 | AD | Addition | 20,000 | 01-15-1988 | 100 | 06-30-1988 | BA ADD'N | | | | | | | |

| LAND LINE VALUATION SECTION | | | | | | | | | | | | | | | | |
|-----------------------------|----------|----------------|------|----|------------|---------------|------------------------|---------|------------|-------|-------|-----------|------------------|--------------------|------------|------------|
| B | Use Code | Description | Zone | LA | Land Units | Unit Price | Size Adj | AC Disc | Site Index | Cond. | Nbhd. | Nbhd. Adj | Notes | Location Adjustmen | Adj Unit P | Land Value |
| 1 | 1010 | Single Fam M-0 | RF-1 | 1 | 1.000 | AC 176,344.00 | 1.00000 | 1.0000 | 5 | 1.00 | 0120 | 12.500 | | 1.0000 | 2,204,300 | 2,204,300 |
| 1 | 1010 | Single Fam M-0 | RF-1 | 1 | 0.500 | AC 14,250.00 | 1.00000 | 1.0000 | 0 | 1.00 | 0120 | 12.500 | | 1.0000 | 178,125 | 89,100 |
| Total Card Land Units | | | | | 1.50 | AC | Parcel Total Land Area | | | | | 1.50 | Total Land Value | | | 2,293,400 |

| CONSTRUCTION DETAIL | | | CONSTRUCTION DETAIL (CONTINUED) | | |
|---------------------|----|----------------|--------------------------------------|----|-------------|
| Element | Cd | Description | Element | Cd | Description |
| Style | 03 | Colonial | | | |
| Model | 01 | Residential | | | |
| Grade: | A+ | Luxury Plus | | | |
| Stories | 2 | 2 Stories | | | |
| Exterior Wall 1 | 14 | Wood Shingle | | | |
| Exterior Wall 2 | 11 | Clapboard | | | |
| Roof Structure | 03 | Gable/Hip | | | |
| Roof Cover | 03 | Asph/F Gls/Cmp | | | |
| Interior Wall 1 | 03 | Plastered | | | |
| Interior Wall 2 | | | | | |
| Interior Floor 1 | 12 | Hardwood | | | |
| Interior Floor 2 | 14 | Carpet | | | |
| Heat Fuel | 03 | Gas | | | |
| Heat Type | 04 | Hot Air | | | |
| AC Type | 03 | Central | | | |
| Bedrooms | 05 | 5 Bedrooms | | | |
| Full Baths | 4 | | | | |
| Half Baths | 2 | | | | |
| Extra Fixtures | | | | | |
| Total Rooms | 12 | | | | |
| Bath Style | | | | | |
| Kitchen Style | | | | | |
| Occupancy | | | | | |
| Usrflid 105 | | | | | |
| Accessory Apt | | | | | |
| Foundation Alt | 01 | Poured Conc. | | | |
| Rms Prts | | | | | |
| Bath Split | 42 | 4 Full-2 Half | | | |
| | | | CONDO DATA | | |
| | | | Parcel Id | C | Ownr 0.0 |
| | | | Adjust Type Code Description Factor% | | |
| | | | Condo Flr | | |
| | | | Condo Unit | | |
| | | | COST / MARKET VALUATION | | |
| | | | Building Value New | | 2,853,233 |
| | | | Year Built | | 1976 |
| | | | Effective Year Built | | 2014 |
| | | | Depreciation Code | | E |
| | | | Remodel Rating | | |
| | | | Year Remodeled | | |
| | | | Depreciation % | | 4 |
| | | | Functional Obsol | | 0 |
| | | | External Obsol | | 0 |
| | | | Trend Factor | | 1 |
| | | | Condition | | |
| | | | Condition % | | |
| | | | Percent Good | | 96 |
| | | | RCNLD | | 2,739,100 |
| | | | Dep % Ovr | | |
| | | | Dep Ovr Comment | | |
| | | | Misc Imp Ovr | | |
| | | | Misc Imp Ovr Comment | | |
| | | | Cost to Cure Ovr | | |
| | | | Cost to Cure Ovr Comment | | |

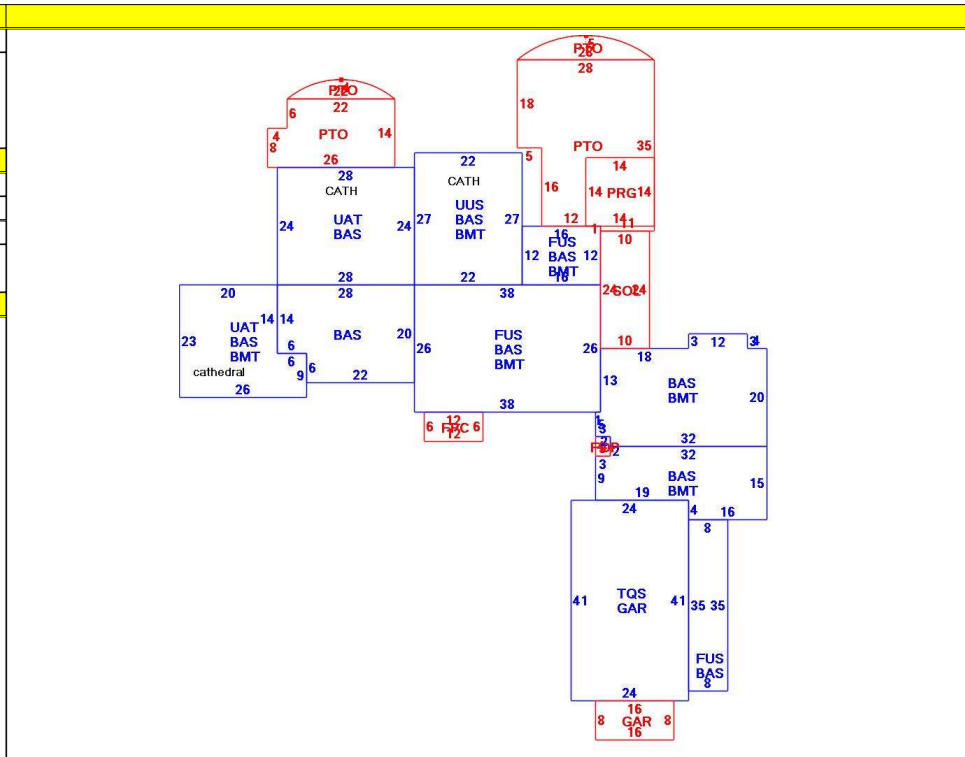

| OB - OUTBUILDING & YARD ITEMS(L) / XF - BUILDING EXTRA FEATURES(B) | | | | | | | | | | |
|--|-----------------|-----|-------|------------|--------|----------|------|-------|------------|-------------|
| Code | Description | L/B | Units | Unit Price | Yr Blt | Cond. Cd | % Gd | Grade | Grade Adj. | Appr. Value |
| FPL3 | Fireplace 2 sto | B | 1 | 7000.00 | 2016 | | 96 | | 0.00 | 6,700 |
| FPO | Ext FP Openin | B | 1 | 2000.00 | 2016 | | 96 | | 0.00 | 1,900 |
| BFA3 | Bsmt Fin-Exc- | B | 704 | 63.36 | 2016 | | 96 | | 0.00 | 42,800 |
| SPL3 | Pool Gunite | L | 1,000 | 75.00 | 2003 | | 68 | 00 | 1.00 | 49,000 |
| PHS2 | Pool Hs/Avg.pl | L | 234 | 120.00 | 2003 | | 84 | A+ | 1.81 | 42,700 |
| GEN | Emergency Ge | L | 1 | 5550.00 | 2005 | | 72 | | 0.00 | 4,000 |
| PRG1 | Pergola-Avg | L | 196 | 18.00 | 1985 | | 32 | A+ | 1.81 | 2,000 |
| FPL1 | Fireplace 1 sto | B | 2 | 5000.00 | 2016 | | 96 | | 0.00 | 9,600 |
| PATS | Patio-Concrete | L | 1,379 | 20.00 | 2008 | | 89 | | 0.00 | 21,200 |
| SOL | Solarium | L | 240 | 171.10 | 2008 | | 89 | A+ | 1.81 | 56,800 |

| BUILDING SUB-AREA SUMMARY SECTION | | | | | | |
|-----------------------------------|------------------------|-------------|------------|----------|-----------|----------------|
| Code | Description | Living Area | Floor Area | Eff Area | Unit Cost | Undeprec Value |
| BAS | First Floor | 4,924 | 4,924 | 4,924 | 372.86 | 1,835,963 |
| BMT | Basement Area | 0 | 3,448 | 0 | 0.00 | 0 |
| FOP | Open Porch | 0 | 12 | 0 | 0.00 | 0 |
| FPC | Open Porch Conc. Floor | 0 | 72 | 0 | 0.00 | 0 |
| FUS | Upper Story | 1,460 | 1,460 | 1,460 | 372.86 | 544,376 |
| GAR | Attached Garage | 0 | 1,112 | 0 | 0.00 | 0 |
| PRG | Pergola | 0 | 196 | 0 | 0.00 | 0 |
| PTO | Patio | 0 | 1,379 | 0 | 0.00 | 0 |
| SOL | Solarium | 0 | 240 | 0 | 0.00 | 0 |
| TQS | Three Quarter Story | 640 | 984 | 640 | 242.51 | 238,630 |
| Ttl Gross Liv / Lease Area | | 7,024 | 15,607 | 7,648 | | 2,851,633 |



| CURRENT OWNER | | TOPO | UTILITIES | STRT / ROAD | LOCATION | CURRENT ASSESSMENT | | | | 801 FY2024 BARNSTABLE, MA VISION | |
|---|--|------------------|----------------|-------------|-----------------|--------------------|------|-----------|-----------|--|-----------|
| HANS, GAYLE B PO BOX 445 CUMMAQUID MA 02637 | | 1 Level | 2 Public Water | 3 Unpaved | 1 Excel View | Description | Code | Assessed | Assessed | | |
| | | | 4 Gas | | 9 Rear Location | RESIDNTL | 1010 | 3,129,500 | 3,129,500 | | |
| | | | 6 Septic | | | RES LAND | 1010 | 2,293,400 | 2,293,400 | | |
| SUPPLEMENTAL DATA | | | | | | Total | | | | 5,422,900 | 5,422,900 |
| Alt Prcl ID | | Split Zonin | | Plan Ref. | | | | | | | |
| BID Parcel | | ResExpt Q | | Land Ct# | | | | | | | |
| #DL 1 | | #DL 2 | | #SR | | | | | | | |
| GIS ID | | F_992724_2720825 | | Assoc Pid# | | | | | | | |

| RECORD OF OWNERSHIP | | BK-VOL/PAGE | SALE DATE | Q/U | V/I | SALE PRIC | VC | PREVIOUS ASSESSMENTS (HISTORY) | | | | | | | | |
|---------------------|--|-------------|-----------|-----|-----|-----------|----|--------------------------------|------|-----------|-------|------|-----------|-------|--|-----------|
| | | | | | | | | Year | Code | Assessed | Year | Code | Assessed | | | |
| | | | | | | | | 2023 | 1010 | 2,686,200 | 2022 | 1010 | 2,237,900 | | | |
| | | | | | | | | | 1010 | 1,841,800 | | 1010 | 2,139,900 | | | |
| | | | | | | | | | | | 2021 | 1010 | 1,840,000 | | | |
| | | | | | | | | | | | | 1010 | 1,762,300 | | | |
| | | | | | | | | | | | | 1010 | 219,000 | | | |
| | | | | | | | | Total | | 4,528,000 | Total | | 4,377,800 | Total | | 3,821,300 |

| EXEMPTIONS | | | OTHER ASSESSMENTS | | | | This signature acknowledges a visit by a Data Collector or Assessor | | | | | |
|------------|------|-------------|-------------------|------|-------------|--------|---|----------|--|--|--|--|
| Year | Code | Description | Amount | Code | Description | Number | Amount | Comm Int | | | | |
| | | | | | | | | | | | | |
| Total | | | | | | | | | | | | |

| ASSESSING NEIGHBORHOOD | | | | APPRAISED VALUE SUMMARY | | | | |
|------------------------|-----------|---|---------|-------------------------|-------------------------------|--|--|-----------|
| Nbhd | Nbhd Name | B | Tracing | Batch | | | | |
| 0120 | | | | BARNS | Appraised Bldg. Value (Card) | | | 2,739,100 |
| | | | | | Appraised Xf (B) Value (Bldg) | | | 171,400 |
| | | | | | Appraised Ob (B) Value (Bldg) | | | 219,000 |
| | | | | | Appraised Land Value (Bldg) | | | 2,293,400 |
| | | | | | Special Land Value | | | 0 |
| | | | | | Total Appraised Parcel Value | | | 5,422,900 |
| | | | | | Valuation Method | | | C |
| | | | | | Total Appraised Parcel Value | | | 5,422,900 |

| NOTES | | | | | | | | | | VISIT / CHANGE HISTORY | | | | |
|-----------|------------|------|-------------|--------|-----------|--------|-----------|----------|------|------------------------|------|----|----|----------------|
| Permit Id | Issue Date | Type | Description | Amount | Insp Date | % Comp | Date Comp | Comments | Date | Id | Type | Is | Cd | Purpost/Result |
| | | | | | | | | | | | | | | |

| BUILDING PERMIT RECORD | | | | | | | | | | | | | VISIT / CHANGE HISTORY | | | | |
|------------------------|------------|------|-------------|--------|-----------|--------|-----------|----------|------|----|------|----|------------------------|----------------|--|--|--|
| Permit Id | Issue Date | Type | Description | Amount | Insp Date | % Comp | Date Comp | Comments | Date | Id | Type | Is | Cd | Purpost/Result | | | |
| | | | | | | | | | | | | | | | | | |

| LAND LINE VALUATION SECTION | | | | | | | | | | | | | | | | |
|-----------------------------|----------|-------------|------|----|------------------------|------------|----------|---------|------------|------------------|-------|-----------|-------|--------------------|------------|------------|
| B | Use Code | Description | Zone | LA | Land Units | Unit Price | Size Adj | AC Disc | Site Index | Cond. | Nbhd. | Nbhd. Adj | Notes | Location Adjustmen | Adj Unit P | Land Value |
| | | | | | | | | | | | | | | | | |
| Total Card Land Units | | | | | Parcel Total Land Area | | | | | Total Land Value | | | | | | |

| CONSTRUCTION DETAIL | | | CONSTRUCTION DETAIL (CONTINUED) | | | | | | | |
|---|-------------------------|----------------|---------------------------------|------------|-------------|----------------|------|-------|------------|-------------|
| Element | Cd | Description | Element | Cd | Description | | | | | |
| Style | 03 | Colonial | | | | | | | | |
| Model | 01 | Residential | | | | | | | | |
| Grade: | A+ | Luxury Plus | | | | | | | | |
| Stories | 2 | 2 Stories | | | | | | | | |
| Exterior Wall 1 | 14 | Wood Shingle | | | | | | | | |
| Exterior Wall 2 | 11 | Clapboard | | | | | | | | |
| Roof Structure | 03 | Gable/Hip | | | | | | | | |
| Roof Cover | 03 | Asph/F Gls/Cmp | | | | | | | | |
| Interior Wall 1 | 03 | Plastered | | | | | | | | |
| Interior Wall 2 | | | | | | | | | | |
| Interior Floor 1 | 12 | Hardwood | | | | | | | | |
| Interior Floor 2 | 14 | Carpet | | | | | | | | |
| Heat Fuel | 03 | Gas | | | | | | | | |
| Heat Type | 04 | Hot Air | | | | | | | | |
| AC Type | 03 | Central | | | | | | | | |
| Bedrooms | 05 | 5 Bedrooms | | | | | | | | |
| Full Baths | 4 | | | | | | | | | |
| Half Baths | 2 | | | | | | | | | |
| Extra Fixtures | | | | | | | | | | |
| Total Rooms | 12 | | | | | | | | | |
| Bath Style | | | | | | | | | | |
| Kitchen Style | | | | | | | | | | |
| Occupancy | | | | | | | | | | |
| Usrflid 105 | | | | | | | | | | |
| Accessory Apt | | | | | | | | | | |
| Foundation Alt | 01 | Poured Conc. | | | | | | | | |
| Rms Prts | | | | | | | | | | |
| Bath Split | 42 | 4 Full-2 Half | | | | | | | | |
| CONDO DATA | | | | | | | | | | |
| Parcel Id | | C | Ownr | 0.0 | | | | | | |
| | | | B | S | | | | | | |
| Adjust Type | Code | Description | Factor% | | | | | | | |
| Condo Flr | | | | | | | | | | |
| Condo Unit | | | | | | | | | | |
| COST / MARKET VALUATION | | | | | | | | | | |
| Building Value New | | | | | | | | | | |
| Year Built | | | | | | | | | | |
| Effective Year Built | | | | | | | | | | |
| Depreciation Code | | | | | | | | | | |
| Remodel Rating | | | | | | | | | | |
| Year Remodeled | | | | | | | | | | |
| Depreciation % | | | | | | | | | | |
| Functional Obsol | | | | | | | | | | |
| External Obsol | | | | | | | | | | |
| Trend Factor | | | | | | | | | | |
| Condition | | | | | | | | | | |
| Condition % | | | | | | | | | | |
| Percent Good | | | | | | | | | | |
| RCNLD | | | | | | | | | | |
| Dep % Ovr | | | | | | | | | | |
| Dep Ovr Comment | | | | | | | | | | |
| Misc Imp Ovr | | | | | | | | | | |
| Misc Imp Ovr Comment | | | | | | | | | | |
| Cost to Cure Ovr | | | | | | | | | | |
| Cost to Cure Ovr Comment | | | | | | | | | | |
| OB - OUTBUILDING & YARD ITEMS(L) / XF - BUILDING EXTRA FEATURES(B) | | | | | | | | | | |
| Code | Description | L/B | Units | Unit Price | Yr Blt | Cond. Cd | % Gd | Grade | Grade Adj. | Appr. Value |
| FOP | Open Porch-ro | B | 12 | 55.00 | 2016 | | 96 | | 0.00 | 1,200 |
| GAR | Attached Gara | B | 1,112 | 40.00 | 2016 | | 96 | | 0.00 | 32,500 |
| BMT | Basement-Unfi | B | 3,448 | 26.01 | 2016 | | 96 | | 0.00 | 68,300 |
| FOPC | Open Prch-roo | B | 72 | 55.00 | 2016 | | 96 | | 0.00 | 3,600 |
| SPH4 | Pool Heater 10 | L | 1 | 5454.00 | 2003 | | 68 | | 0.00 | 3,700 |
| SPC1 | Pool Cover-Au | L | 1,000 | 17.53 | 2003 | | 68 | | 0.00 | 11,900 |
| FPLG | Gas Fireplace- | B | 2 | 2500.00 | 2016 | | 96 | | 0.00 | 4,800 |
| FOPD | FOP-CONCR | L | 144 | 31.41 | 2003 | | 84 | A+ | 1.81 | 6,200 |
| PAT1 | Patio- Average | L | 2,465 | 5.89 | 2003 | | 84 | | 0.00 | 9,900 |
| SPDC | POOL DECK | L | 2,465 | 5.61 | 2003 | | 84 | | 0.00 | 11,600 |
| BUILDING SUB-AREA SUMMARY SECTION | | | | | | | | | | |
| Code | Description | Living Area | Floor Area | Eff Area | Unit Cost | Undeprec Value | | | | |
| UAT | Attic, Unfinished | 0 | 1,186 | 119 | 37.41 | 44,370 | | | | |
| UUS | Upper Story, Unfinished | 0 | 594 | 505 | 316.99 | 188,294 | | | | |
| Ttl Gross Liv / Lease Area | | | | | | | | | | |