

CURRENT OWNER		TOPO	UTILITIES	STRT / ROAD	LOCATION	CURRENT ASSESSMENT						801 FY2024 BARNSTABLE, MA VISION						
BACON, ROGER W & BARBARA S 281 NORTH ST BELCHERTOWN MA 01007						Description	Code	Assessed	Assessed									
		SUPPLEMENTAL DATA				RESIDNTL	1020	431,400	431,400									
		Alt Prcl ID	Split Zonin	BID Parcel	ResExpt Q	#DL 1	UNIT 11	#DL 2	GIS ID	F_992775_2722828	Plan Ref.			253/74-F2, 249/13	Land Ct#	#SR	Life Estate	PP STATU
						Total		431,400	431,400									
RECORD OF OWNERSHIP		BK-VOL/PAGE	SALE DATE	Q/U	V/I	SALE PRICE	VC	PREVIOUS ASSESSMENTS (HISTORY)										
BACON, ROGER W & BARBARA S		15536 0309	08-30-2002	U	I	1	1A	Year	Code	Assessed	Year	Code	Assessed	Year	Code	Assessed		
BACON, ROGER		15536 0282	08-30-2002	Q	I	186,000	00	2023	1020	355,800	2022	1020	295,100	2021	1020	292,900		
SIMENSEN, GERALD		1595 0226	01-31-1972	Q	I	20,990	00							1020	2,200			
						Total		355,800	Total	295,100	Total	295,100						
EXEMPTIONS			OTHER ASSESSMENTS				This signature acknowledges a visit by a Data Collector or Assessor											
Year	Code	Description	Amount	Code	Description	Number	Amount	Comm Int										
		Total	0.00															
ASSESSING NEIGHBORHOOD							APPRAISED VALUE SUMMARY											
Nbhd	Nbhd Name		B	Tracing		Batch												
0001						BARNS												
NOTES																		
BUILDING PERMIT RECORD										VISIT / CHANGE HISTORY								
Permit Id	Issue Date	Type	Description	Amount	Insp Date	% Comp	Date Comp	Comments		Date	Id	Type	Is	Cd	Purpost/Result			
										05-01-2020	DM			FR	Field Review			
										02-09-2018	KM	02		03	Cycl Insp Comp			
										03-23-2010	TP	03		16	In Office Review			
										08-15-1989	GB	01		00	Meas/Listed-Interior Acces			
LAND LINE VALUATION SECTION																		
B	Use Code	Description	Zone	Dist	Land Type	Land Units	Unit Price	Size Adj	Site Index	Cond.	Nbhd.	Nbhd. Adj	Notes	Location Adjustmen	Adj Unit P	Land Value		
1	102U	Condominium M	RF-1	1		0 SF	0.00	1.00000	5	1.00	0001	1.000		0.0000	0	0		
Total Card Land Units						0 SF	Parcel Total Land Area						0.00	Total Land Value				0

CONSTRUCTION DETAIL			CONSTRUCTION DETAIL (CONTINUED)		
Element	Cd	Description	Element	Cd	Description
Style	55	Condominium			
Model	05	Res Condo			
Bedrm Func	C	Average			
Stories	1	1 Story			
Occupancy	0				
Interior Wall 1	05	Drywall			
Interior Wall 2					
Interior Floor 1	20	Typical			
Interior Floor 2					
Heat Fuel	01	None			
Heat Type	01	None			
AC Type	01	None			
Bedrooms	02	2 Bedrooms			
Full Baths	1	1 Full			
Half Baths	0				
Extra Fixtures					
Total Rooms	4	4 Rooms			
Bath Style					
Kitchen Style					
Master Deed L	528				
Bath Split	10	1 Full-0 Half			
Foundation	09	Blk/Pour Ftgs			
AC Type Alt					
Sewer Occupan					
CONDO DATA					
Parcel Id	104248	C 0330	Owne	4.3	
	CAPE COD VILLA	B 1	S 1		
Adjust Type	Code	Description	Factor%		
Condo Flr	01	INLAND	100		
Condo Unit	MKT0	MKT0	100		
COST / MARKET VALUATION					
Building Value New			552,318		
Year Built			1949		
Effective Year Built			1989		
Depreciation Code			A		
Remodel Rating					
Year Remodeled					
Depreciation %			23		
Functional Obsol			0		
External Obsol			0		
Trend Factor			1		
Condition					
Condition %					
Percent Good			77		
Cns Sect Rcnd			425,300		
Dep % Ovr					
Dep Ovr Comment					
Misc Imp Ovr					
Misc Imp Ovr Comment					
Cost to Cure Ovr					
Cost to Cure Ovr Comment					

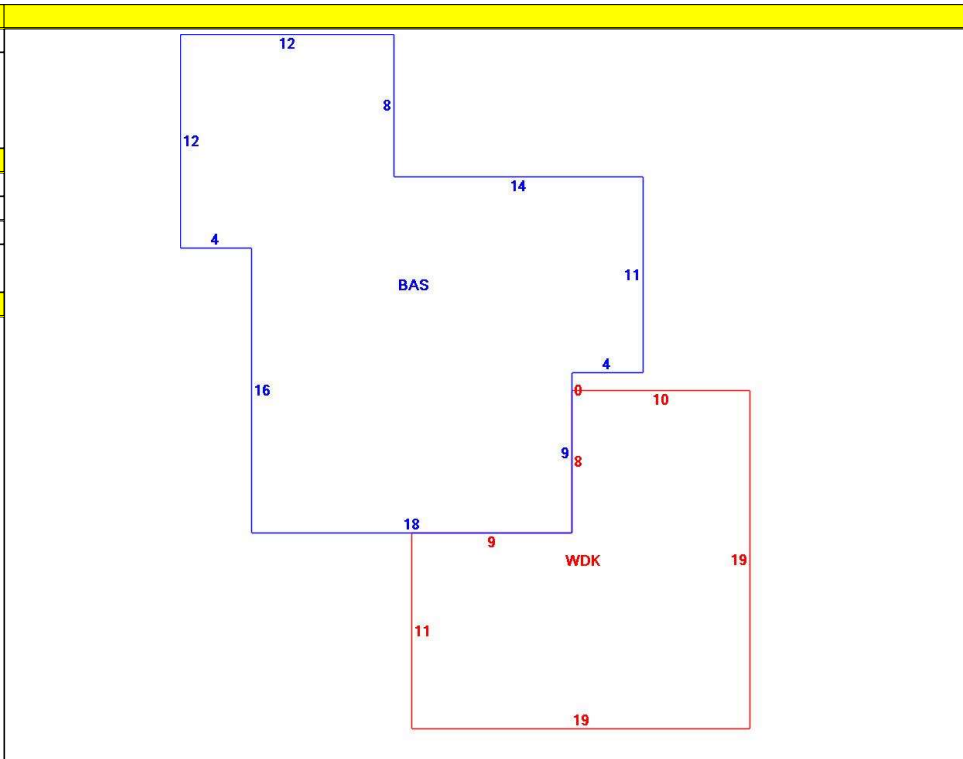

OB - OUTBUILDING & YARD ITEMS(L) / XF - BUILDING EXTRA FEATURES(B)

Code	Description	L/B	Units	Unit Price	Yr Blt	Cond. Cd	% Gd	Grade	Grade Adj.	Appr. Value
FPL1	Fireplace 1 sto	B	1	5000.00	1990		77		0.00	3,900
WDC	Wood Deck w/	L	289	18.00	1990		42		0.00	2,200

BUILDING SUB-AREA SUMMARY SECTION

Code	Description	Living Area	Floor Area	Eff Area	Unit Cost	Undeprec Value
BAS	First Floor	516	516	516	1,070.38	552,318
WDC	Wood Deck	0	289	0	0.00	0
Ttl Gross Liv / Lease Area		516	805	516		552,318

