

CURRENT OWNER		TOPO	UTILITIES	STRT / ROAD	LOCATION	CURRENT ASSESSMENT					
LYNCH, CHARLES O & MARGARET T CHARLES O LYNCH 2018 REVOC TR 119 TROWBRIDGE CIRCLE  STOUGHTON MA 02072						Description	Code	Assessed	Assessed	801  FY2024 BARNSTABLE, MA  <b>VISION</b>	
						RESIDNTL	1020	406,700	406,700		
SUPPLEMENTAL DATA						Total					
Alt Prcl ID Split Zonin BID Parcel ResExpt Q #DL 1 UNIT 18 #DL 2 GIS ID F_992775_2722828				Plan Ref. 253/77-F1, 249/13 Land Ct# #SR Life Estate PP STATU  Assoc Pid#		406,700		406,700			

RECORD OF OWNERSHIP		BK-VOL/PAGE	SALE DATE	Q/U	V/I	SALE PRICE	VC	PREVIOUS ASSESSMENTS (HISTORY)								
LYNCH, CHARLES O & MARGARET TRS	31266	0160	05-15-2018	U	I	100	1A	Year	Code	Assessed	Year	Code	Assessed	Year	Code	Assessed
LYNCH CHARLES O & MARGARET H	31266	0154	05-15-2018	U	I	100	1F	2023	1020	335,000	2022	1020	277,300	2021	1020	274,600
LYNCH, CHARLES O JR & MARGARET A TR	24117	0323	10-26-2009	U	I	1	1F								1020	2,700
LYNCH, CHARLES O JR & MARGARET A	4642	0166	07-15-1985	Q	I	72,000	U									
NOBER, LINDA M	2559	0081	08-04-1977	U		0		Total		335,000	Total		277,300	Total		277,300

EXEMPTIONS			OTHER ASSESSMENTS					
Year	Code	Description	Amount	Code	Description	Number	Amount	Comm Int
Total			0.00					

ASSESSING NEIGHBORHOOD				
Nbhd	Nbhd Name	B	Tracing	Batch
0001				BARNS

NOTES	
This signature acknowledges a visit by a Data Collector or Assessor	

  

APPRAISED VALUE SUMMARY	
Appraised Bldg. Value (Card)	403,800
Appraised Xf (B) Value (Bldg)	200
Appraised Ob (B) Value (Bldg)	2,700
Appraised Land Value (Bldg)	0
Special Land Value	0
Total Appraised Parcel Value	406,700
Valuation Method	C
Total Appraised Parcel Value	406,700

BUILDING PERMIT RECORD						VISIT / CHANGE HISTORY								
Permit Id	Issue Date	Type	Description	Amount	Insp Date	% Comp	Date Comp	Comments	Date	Id	Type	Is	Cd	Purpost/Result
									05-04-2020	DM			FR	Field Review
									02-09-2018	SR	02		03	Cycl Insp Comp
									08-15-1989	ML	01		00	Meas/Listed-Interior Acces

LAND LINE VALUATION SECTION																		
B	Use Code	Description	Zone	Dist	Land Type	Land Units	Unit Price	Size Adj	Site Index	Cond.	Nbhd.	Nbhd. Adj	Notes	Location Adjustmen	Adj Unit P	Land Value		
1	102U	Condominium M	RF-1	1		0 SF	0.00	1.00000	5	1.00	0001	1.000		0.0000	0	0		
Total Card Land Units						0 SF	Parcel Total Land Area						0.00	Total Land Value				0

CONSTRUCTION DETAIL			CONSTRUCTION DETAIL (CONTINUED)		
Element	Cd	Description	Element	Cd	Description
Style	55	Condominium			
Model	05	Res Condo			
Bedrm Func	C	Average			
Stories	1	1 Story			
Occupancy	0				
Interior Wall 1	07	Knotty Pine			
Interior Wall 2					
Interior Floor 1	09	Pine/Soft Wood			
Interior Floor 2					
Heat Fuel	04	Electric			
Heat Type	07	Elec Baseboard			
AC Type	01	None			
Bedrooms	02	2 Bedrooms			
Full Baths	1	1 Full			
Half Baths	0				
Extra Fixtures					
Total Rooms	4	4 Rooms			
Bath Style					
Kitchen Style					
Master Deed L	608				
Bath Split	10	1 Full-0 Half			
Foundation	09	Blk/Pour Ftgs			
AC Type Alt					
Sewer Occupan					
<b>CONDO DATA</b>					
Parcel Id	104248	C 0330	Ownr	4.5	
	CAPE COD VILLA	B 1	S 1		
Adjust Type	Code	Description	Factor%		
Condo Flr	01	INLAND	100		
Condo Unit	MKT0	MKT0	100		
<b>COST / MARKET VALUATION</b>					
Building Value New		524,436			
Year Built		1948			
Effective Year Built		1989			
Depreciation Code		A			
Remodel Rating					
Year Remodeled					
Depreciation %		23			
Functional Obsol		0			
External Obsol		0			
Trend Factor		1			
Condition					
Condition %					
Percent Good		77			
Cns Sect Rcnld		403,800			
Dep % Ovr					
Dep Ovr Comment					
Misc Imp Ovr					
Misc Imp Ovr Comment					
Cost to Cure Ovr					
Cost to Cure Ovr Comment					

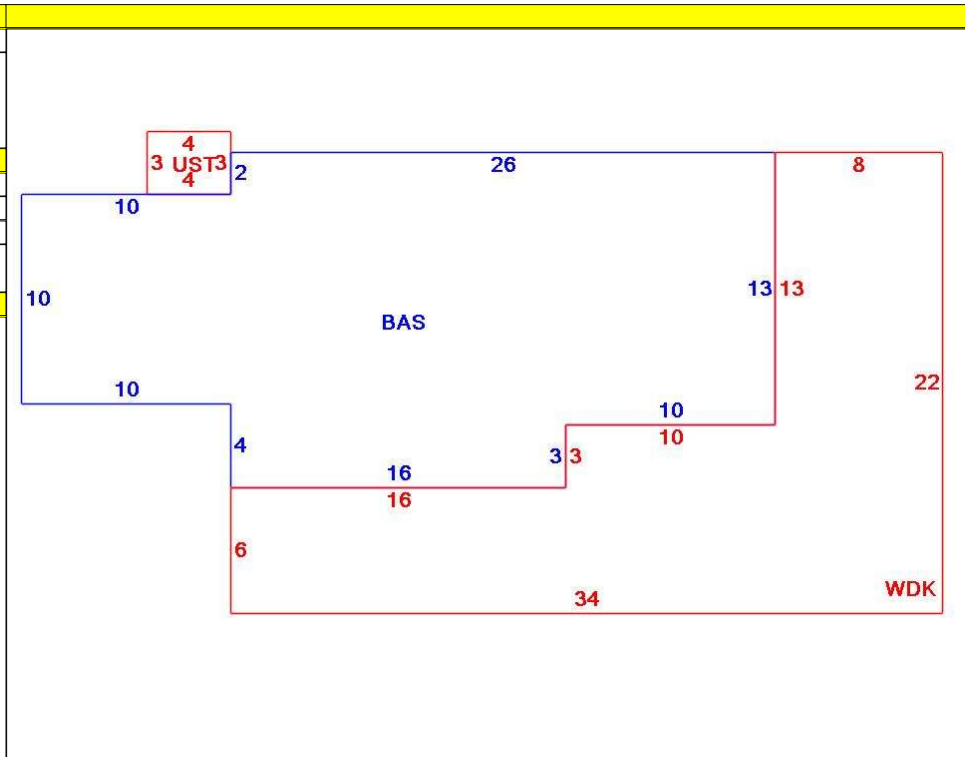

OB - OUTBUILDING & YARD ITEMS(L) / XF - BUILDING EXTRA FEATURES(B)										
Code	Description	L/B	Units	Unit Price	Yr Blt	Cond. Cd	% Gd	Grade	Grade Adj.	Appr. Value
WDC	Wood Deck w/	L	362	18.00	1990		42		0.00	2,700
UST	Utility Storage-	B	12	17.11	1990		77		0.00	200

BUILDING SUB-AREA SUMMARY SECTION						
Code	Description	Living Area	Floor Area	Eff Area	Unit Cost	Undeprec Value
BAS	First Floor	486	486	486	1,079.09	524,436
UST	Utility Enclosure	0	12	0	0.00	0
WDK	Wood Deck	0	362	0	0.00	0
Ttl Gross Liv / Lease Area		486	860	486		524,436

