

| CURRENT OWNER | | TOPO | UTILITIES | STRT / ROAD | LOCATION | CURRENT ASSESSMENT | | | | 801 FY2024 BARNSTABLE, MA VISION | |
|--|--|-------------|----------------|------------------|----------|--------------------|------|----------|----------|--|---------|
| BARRY, WILLIAM E & SUSAN M PO BOX 503 YARMOUTH PO MA 02675 | | 1 Level | 2 Public Water | 1 Paved | | Description | Code | Assessed | Assessed | | |
| | | | 4 Gas | | | RESIDNTL | 1010 | 723,800 | 723,800 | | |
| | | | 6 Septic | | | RES LAND | 1010 | 243,700 | 243,700 | | |
| SUPPLEMENTAL DATA | | | | | | Total | | | | 967,500 | 967,500 |
| Alt Prcl ID | | Split Zonin | | Plan Ref. 428/26 | | | | | | | |
| BID Parcel | | | | Land Ct# | | | | | | | |
| ResExpt Q YES: | | | | #SR | | | | | | | |
| #DL 1 LOT 107A | | | | Life Estate | | | | | | | |
| #DL 2 | | | | PP STATU | | | | | | | |
| GIS ID F_994511_2717508 | | | | Assoc Pid# | | | | | | | |

| RECORD OF OWNERSHIP | | BK-VOL/PAGE | SALE DATE | Q/U | V/I | SALE PRIC | VC | PREVIOUS ASSESSMENTS (HISTORY) | | | | | | | | | |
|--------------------------------|--|-------------|-----------|------------|-----|-----------|---------|--------------------------------|-------|------|----------|-------|------|----------|-------|------|----------|
| BARRY, WILLIAM E & SUSAN M | | 11092 | 0199 | 12-02-1997 | U | V | 1 | 1A | Year | Code | Assessed | Year | Code | Assessed | Year | Code | Assessed |
| BARRY, WILLIAM E | | 11052 | 0101 | 11-07-1997 | Q | V | 100,000 | 00 | 2023 | 1010 | 648,900 | 2022 | 1010 | 544,600 | 2021 | 1010 | 464,200 |
| FLATLEY, CHARLOTTE E ET AL TRS | | 9717 | 0186 | 06-15-1995 | Q | V | 90,000 | U | | 1010 | 221,500 | | 1010 | 152,400 | | 1010 | 154,700 |
| HENRY, NOEL G & WINIFRED A | | 6681 | 0139 | 03-15-1989 | U | V | 1 | A | | | | | | | | 1010 | 5,300 |
| HENRY, NOEL G | | 5504 | 0050 | 01-15-1987 | U | V | 290,000 | N | Total | | 870,400 | Total | | 697,000 | Total | | 624,200 |

| EXEMPTIONS | | | | OTHER ASSESSMENTS | | | | This signature acknowledges a visit by a Data Collector or Assessor | | | | | | | | | | |
|------------|------|-----------------------|--------|-------------------|-------------|--------|--------|---|--|--|--|--|--|--|--|--|--|--|
| Year | Code | Description | Amount | Code | Description | Number | Amount | Comm Int | | | | | | | | | | |
| 2011 | 5C | RESIDENTIAL EXEMPTION | 0.00 | | | | | | | | | | | | | | | |
| Total | | | 0.00 | | | | | | | | | | | | | | | |

| ASSESSING NEIGHBORHOOD | | | | APPRAISED VALUE SUMMARY | | | |
|------------------------|-----------|---|---------|-------------------------|-------------------------------|---------|--|
| Nbhd | Nbhd Name | B | Tracing | Batch | | | |
| 0107 | | | | BARNS | Appraised Bldg. Value (Card) | 648,100 | |
| | | | | | Appraised Xf (B) Value (Bldg) | 70,400 | |
| | | | | | Appraised Ob (B) Value (Bldg) | 5,300 | |
| | | | | | Appraised Land Value (Bldg) | 243,700 | |
| | | | | | Special Land Value | 0 | |
| | | | | | Total Appraised Parcel Value | 967,500 | |
| | | | | | Valuation Method | C | |
| | | | | | Total Appraised Parcel Value | 967,500 | |

| NOTES | | | | | | | | | | VISIT / CHANGE HISTORY | | | | | |
|-------|--|--|--|--|--|--|--|--|--|------------------------|----|------|----|----|------------------|
| | | | | | | | | | | Date | Id | Type | Is | Cd | Purpost/Result |
| | | | | | | | | | | 03-20-2022 | DB | 01 | 1 | 03 | Cycl Insp Comp |
| | | | | | | | | | | 05-04-2020 | DM | | | FR | Field Review |
| | | | | | | | | | | 02-12-2019 | CL | | | 16 | In Office Review |
| | | | | | | | | | | 03-13-2015 | SR | 01 | | 03 | Cycl Insp Comp |

| BUILDING PERMIT RECORD | | | | | | | | | | LAND LINE VALUATION SECTION | | | | | |
|------------------------|------------|------|-------------|---------|------------|--------|------------|----------|--|-----------------------------|----|------|----|----|----------------|
| Permit Id | Issue Date | Type | Description | Amount | Insp Date | % Comp | Date Comp | Comments | | Date | Id | Type | Is | Cd | Purpost/Result |
| 34423 | 10-30-1998 | DW | Dwelling | 130,460 | 01-01-1999 | 100 | 01-01-2000 | | | | | | | | |

| B | Use Code | Description | Zone | LA | Land Units | Unit Price | Size Adj | AC Disc | Site Index | Cond. | Nbhd. | Nbhd. Adj | Notes | Location Adjustmen | Adj Unit P | Land Value | | |
|-----------------------|----------|----------------|------|----|------------|------------|------------------------|---------|------------|-------|-------|-----------|------------------|----------------------|------------|------------|-----------|---------|
| 1 | 1010 | Single Fam M-0 | RF-2 | 1 | 0.860 | AC | 176,344.00 | 1.14768 | 1.0000 | 5 | 1.00 | 0107 | 1.400 | GOLF COURSE FRONTAGE | | 1.0000 | 283,349.5 | 243,700 |
| Total Card Land Units | | | | | 0.86 | AC | Parcel Total Land Area | | | | | 0.86 | Total Land Value | | | | | 243,700 |

| CONSTRUCTION DETAIL | | | CONSTRUCTION DETAIL (CONTINUED) | | |
|---------------------|------|----------------|---------------------------------|----|-------------|
| Element | Cd | Description | Element | Cd | Description |
| Style | 04 | Cape Cod | | | |
| Model | 01 | Residential | | | |
| Grade: | C+ | Average Plus | | | |
| Stories | 1.66 | | | | |
| Exterior Wall 1 | 14 | Wood Shingle | | | |
| Exterior Wall 2 | 11 | Clapboard | | | |
| Roof Structure | 03 | Gable/Hip | | | |
| Roof Cover | 03 | Asph/F Gls/Cmp | | | |
| Interior Wall 1 | 03 | Plastered | | | |
| Interior Wall 2 | | | | | |
| Interior Floor 1 | 12 | Hardwood | | | |
| Interior Floor 2 | 14 | Carpet | | | |
| Heat Fuel | 03 | Gas | | | |
| Heat Type | 04 | Hot Air | | | |
| AC Type | 03 | Central | | | |
| Bedrooms | 03 | 3 Bedrooms | | | |
| Full Baths | 2 | | | | |
| Half Baths | 1 | | | | |
| Extra Fixtures | | | | | |
| Total Rooms | 7 | 7 Rooms | | | |
| Bath Style | | | | | |
| Kitchen Style | | | | | |
| Occupancy | | | | | |
| Usrflid 105 | | | | | |
| Accessory Apt | | | | | |
| Foundation Alt | 01 | Poured Conc. | | | |
| Rms Prts | | | | | |
| Bath Split | 21 | 2 Full-1 Half | | | |

| CONDO DATA | | | | |
|-------------|------|-------------|---------|----------|
| Parcel Id | | C | | Owne 0.0 |
| | | | B | S |
| Adjust Type | Code | Description | Factor% | |
| Condo Flr | | | | |
| Condo Unit | | | | |

| COST / MARKET VALUATION | |
|--------------------------|---------|
| Building Value New | 728,171 |
| Year Built | 1999 |
| Effective Year Built | 2005 |
| Depreciation Code | A |
| Remodel Rating | |
| Year Remodeled | |
| Depreciation % | 11 |
| Functional Obsol | 0 |
| External Obsol | 0 |
| Trend Factor | 1 |
| Condition | |
| Condition % | |
| Percent Good | 89 |
| RCNLD | 648,100 |
| Dep % Ovr | |
| Dep Ovr Comment | |
| Misc Imp Ovr | |
| Misc Imp Ovr Comment | |
| Cost to Cure Ovr | |
| Cost to Cure Ovr Comment | |

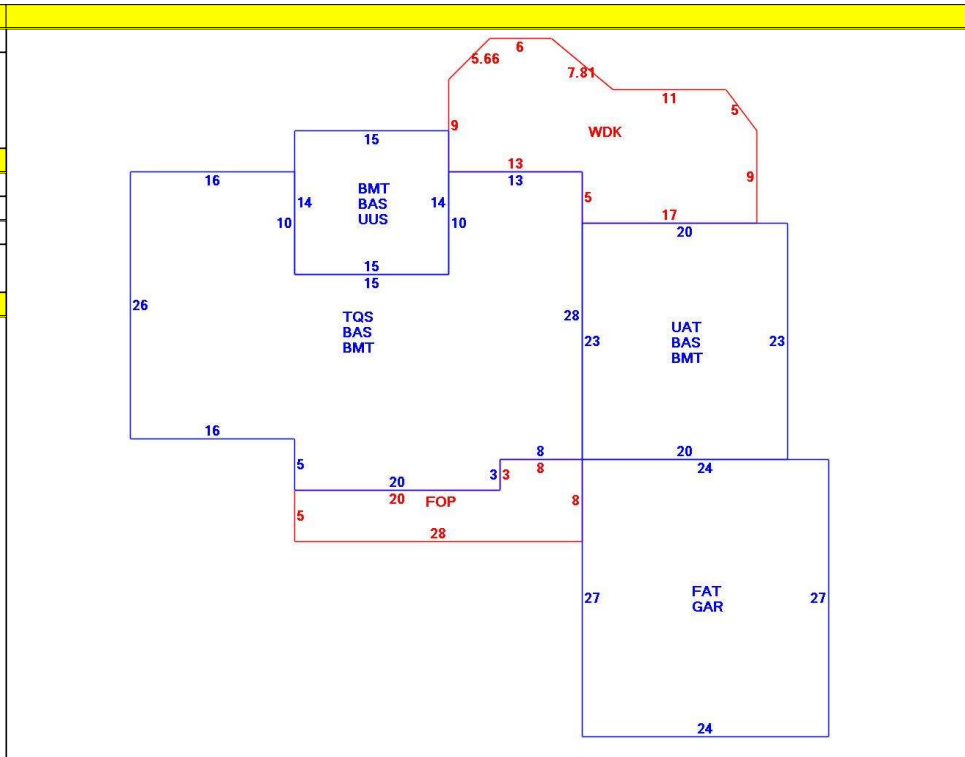

OB - OUTBUILDING & YARD ITEMS(L) / XF - BUILDING EXTRA FEATURES(B)

| Code | Description | L/B | Units | Unit Price | Yr Blt | Cond. Cd | % Gd | Grade | Grade Adj. | Appr. Value |
|------|-----------------|-----|-------|------------|--------|----------|------|-------|------------|-------------|
| FPL2 | Fireplace 1.5 s | B | 1 | 6000.00 | 2007 | | 89 | | 0.00 | 5,300 |
| WDC | Wood Decking | L | 376 | 20.00 | 2005 | | 72 | | 0.00 | 5,300 |
| FOP | Open Porch-ro | B | 164 | 55.00 | 2007 | | 89 | | 0.00 | 7,000 |
| GAR | Attached Gara | B | 648 | 40.00 | 2007 | | 89 | | 0.00 | 19,800 |
| BMT | Basement-Unfi | B | 1,780 | 26.01 | 2007 | | 89 | | 0.00 | 36,100 |
| FPLG | Gas Fireplace- | B | 1 | 2500.00 | 2007 | | 89 | | 0.00 | 2,200 |

BUILDING SUB-AREA SUMMARY SECTION

| Code | Description | Living Area | Floor Area | Eff Area | Unit Cost | Undeprec Value |
|----------------------------|-------------------------|-------------|------------|----------|-----------|----------------|
| BAS | First Floor | 1,780 | 1,780 | 1,780 | 257.85 | 458,975 |
| BMT | Basement Area | 0 | 1,780 | 0 | 0.00 | 0 |
| FAT | Attic, Finished | 97 | 648 | 97 | 38.60 | 25,012 |
| FOP | Open Porch | 0 | 164 | 0 | 0.00 | 0 |
| GAR | Attached Garage | 0 | 648 | 0 | 0.00 | 0 |
| TQS | Three Quarter Story | 722 | 1,110 | 722 | 167.72 | 186,168 |
| UAT | Attic, Unfinished | 0 | 460 | 46 | 25.79 | 11,861 |
| UUS | Upper Story, Unfinished | 0 | 210 | 179 | 219.79 | 46,155 |
| WDK | Wood Deck | 0 | 376 | 0 | 0.00 | 0 |
| Ttl Gross Liv / Lease Area | | 2,599 | 7,176 | 2,824 | | 728,171 |

