

| CURRENT OWNER | | TOPO | UTILITIES | STRT / ROAD | LOCATION | CURRENT ASSESSMENT | | | |
|---|--|-------------|----------------|-------------------|----------|--------------------|---------|----------|----------|
| CUTLER, NORMAN W & MARY A TRS CUTLER FAMILY TRUST P O BOX 342 CUMMAQUID MA 02637 | | 1 Level | 2 Public Water | 1 Paved | | Description | Code | Assessed | Assessed |
| | | | 4 Gas | | | RESIDNTL | 1010 | 547,100 | 547,100 |
| | | | 6 Septic | | | RES LAND | 1010 | 232,100 | 232,100 |
| SUPPLEMENTAL DATA | | | | | | | | | |
| Alt Prcl ID | | Split Zonin | | Plan Ref. | | | | | |
| BID Parcel | | ResExpt Q | | Land Ct# | | | | | |
| #DL 1 LOT 114 | | | | #SR | | | | | |
| #DL 2 | | | | Life Estate | | | | | |
| GIS ID F_994699_2717281 | | | | PP STATU A:Active | | | | | |
| | | | | Assoc Pid# | | | | | |
| | | | | | | Total | 779,200 | 779,200 | |

801
 FY2024
 BARNSTABLE, MA

VISION

| RECORD OF OWNERSHIP | | BK-VOL/PAGE | SALE DATE | Q/U | V/I | SALE PRIC | VC | PREVIOUS ASSESSMENTS (HISTORY) | | | | | |
|-------------------------------|-------|-------------|------------|-----|-----|-----------|----|--------------------------------|---------|----------|---------|-------|----------|
| CUTLER, NORMAN W & MARY A TRS | 23350 | 0234 | 01-05-2009 | U | I | 1 | 1F | Year | Code | Assessed | Year | Code | Assessed |
| CUTLER, NORMAN W & MARY A | 12589 | 0127 | 10-06-1999 | Q | I | 298,000 | 00 | 2023 | 1010 | 485,500 | 2022 | 1010 | 413,200 |
| LANGWAY, JAMES A & ELEANOR L | 5159 | 0042 | 06-15-1986 | U | I | 1 | A | | 1010 | 211,000 | | 1010 | 145,100 |
| LANGWAY, JAMES H | 4333 | 0196 | 11-15-1984 | Q | I | 135,000 | U | | | | | 1010 | 5,700 |
| LANGSTROTH, DOROTHY B | 3598 | 0260 | 11-15-1982 | U | | 0 | | | | | | | |
| | | | | | | | | Total | 696,500 | Total | 558,300 | Total | 504,700 |

| EXEMPTIONS | | | OTHER ASSESSMENTS | | | | | |
|------------|------|-------------|-------------------|------|-------------|--------|--------|----------|
| Year | Code | Description | Amount | Code | Description | Number | Amount | Comm Int |
| | | | | | | | | |
| Total | | | 0.00 | | | | | |

This signature acknowledges a visit by a Data Collector or Assessor

| ASSESSING NEIGHBORHOOD | | | | |
|------------------------|-----------|---|---------|-------|
| Nbhd | Nbhd Name | B | Tracing | Batch |
| 0107 | | | | BARNS |

| NOTES | | | |
|-------|--|--|--|
| | | | |

| APPRAISED VALUE SUMMARY | |
|-------------------------------|---------|
| Appraised Bldg. Value (Card) | 486,600 |
| Appraised Xf (B) Value (Bldg) | 54,800 |
| Appraised Ob (B) Value (Bldg) | 5,700 |
| Appraised Land Value (Bldg) | 232,100 |
| Special Land Value | 0 |
| Total Appraised Parcel Value | 779,200 |
| Valuation Method | C |
| Total Appraised Parcel Value | 779,200 |

| BUILDING PERMIT RECORD | | | | | | | | VISIT / CHANGE HISTORY | | | | | | |
|------------------------|--------------------------|-----------|----------------------------|-----------------|------------|------------|------------|--|--|----------------------|----------------|----|----------------------|---|
| Permit Id | Issue Date | Type | Description | Amount | Insp Date | % Comp | Date Comp | Comments | Date | Id | Type | Is | Cd | Purpost/Result |
| EXPR-21-5 B31061 | 03-31-2021 08-01-1987 | 835 AD | Sid/Wind/Roof/ Addition | 4,559 12,000 | 01-15-1988 | 100 100 | 06-30-1988 | insulation and air sealing work BA SUN RM | 03-20-2023 05-04-2020 03-13-2015 08-25-2014 | DB DM SR JR | 03 02 03 | | 02 FR 03 16 | Bldg Permit Completed Field Review Cycl Insp Comp In Office Review |

| LAND LINE VALUATION SECTION | | | | | | | | | | | | | | | | | | |
|-----------------------------|----------|----------------|------|----|------------|------------|------------------------|---------|------------|-------|-------|-----------|------------------|----------------------|------------|------------|-----------|---------|
| B | Use Code | Description | Zone | LA | Land Units | Unit Price | Size Adj | AC Disc | Site Index | Cond. | Nbhd. | Nbhd. Adj | Notes | Location Adjustmen | Adj Unit P | Land Value | | |
| 1 | 1010 | Single Fam M-0 | RF-2 | 1 | 0.610 | AC | 176,344.00 | 1.54133 | 1.0000 | 5 | 1.00 | 0107 | 1.400 | GOLF COURSE FRONTAGE | | 1.0000 | 380,532.7 | 232,100 |
| Total Card Land Units | | | | | 0.61 | AC | Parcel Total Land Area | | | | | 0.61 | Total Land Value | | | | | 232,100 |

| CONSTRUCTION DETAIL | | | CONSTRUCTION DETAIL (CONTINUED) | | |
|---------------------|-----|----------------|---------------------------------|----|-------------|
| Element | Cd | Description | Element | Cd | Description |
| Style | 04 | Cape Cod | | | |
| Model | 01 | Residential | | | |
| Grade: | C+ | Average Plus | | | |
| Stories | 1.5 | 1 1/2 Stories | | | |
| Exterior Wall 1 | 14 | Wood Shingle | | | |
| Exterior Wall 2 | 25 | Vinyl Siding | | | |
| Roof Structure | 03 | Gable/Hip | | | |
| Roof Cover | 03 | Asph/F Gls/Cmp | | | |
| Interior Wall 1 | 03 | Plastered | | | |
| Interior Wall 2 | | | | | |
| Interior Floor 1 | 14 | Carpet | | | |
| Interior Floor 2 | 12 | Hardwood | | | |
| Heat Fuel | 03 | Gas | | | |
| Heat Type | 05 | Hot Water | | | |
| AC Type | 03 | Central | | | |
| Bedrooms | 03 | 3 Bedrooms | | | |
| Full Baths | 2 | | | | |
| Half Baths | 0 | | | | |
| Extra Fixtures | | | | | |
| Total Rooms | 7 | 7 Rooms | | | |
| Bath Style | | | | | |
| Kitchen Style | | | | | |
| Occupancy | | | | | |
| Usrflid 105 | | | | | |
| Accessory Apt | | | | | |
| Foundation Alt | 01 | Poured Conc. | | | |
| Rms Prts | | | | | |
| Bath Split | 20 | 2 Full-0 Half | | | |

| CONDO DATA | | | | |
|-------------|------|-------------|---------|----------|
| Parcel Id | | C | | Owne 0.0 |
| | | | B | S |
| Adjust Type | Code | Description | Factor% | |
| Condo Flr | | | | |
| Condo Unit | | | | |

| COST / MARKET VALUATION | |
|--------------------------|---------|
| Building Value New | 623,812 |
| Year Built | 1970 |
| Effective Year Built | 1991 |
| Depreciation Code | A |
| Remodel Rating | |
| Year Remodeled | |
| Depreciation % | 22 |
| Functional Obsol | 0 |
| External Obsol | 0 |
| Trend Factor | 1 |
| Condition | |
| Condition % | |
| Percent Good | 78 |
| RCNLD | 486,600 |
| Dep % Ovr | |
| Dep Ovr Comment | |
| Misc Imp Ovr | |
| Misc Imp Ovr Comment | |
| Cost to Cure Ovr | |
| Cost to Cure Ovr Comment | |

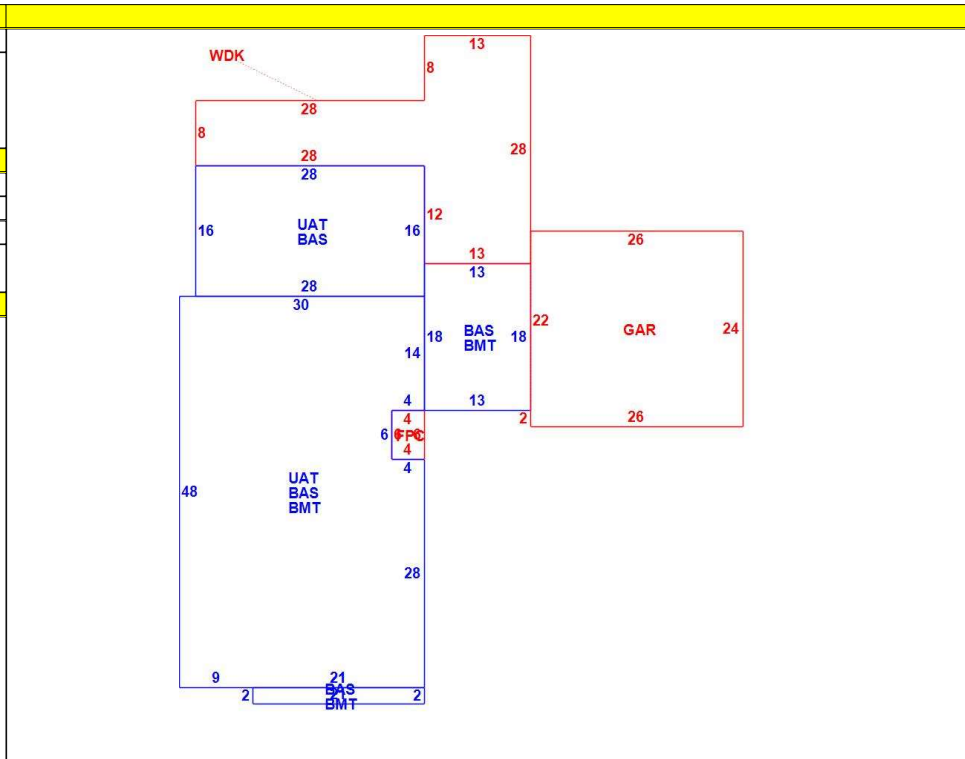

| OB - OUTBUILDING & YARD ITEMS(L) / XF - BUILDING EXTRA FEATURES(B) | | | | | | | | | | |
|--|-----------------|-----|-------|------------|--------|----------|------|-------|------------|-------------|
| Code | Description | L/B | Units | Unit Price | Yr Blt | Cond. Cd | % Gd | Grade | Grade Adj. | Appr. Value |
| FPL2 | Fireplace 1.5 s | B | 1 | 6000.00 | 1993 | | 78 | | 0.00 | 4,700 |
| FPO | Ext FP Openin | B | 1 | 2000.00 | 1993 | | 78 | | 0.00 | 1,600 |
| WDC | Wood Decking | L | 588 | 20.00 | 1995 | | 52 | | 0.00 | 5,700 |
| FOPC | Open Prch-roo | B | 24 | 55.00 | 1993 | | 78 | | 0.00 | 1,300 |
| GAR | Attached Gara | B | 624 | 40.00 | 1993 | | 78 | | 0.00 | 16,900 |
| BMT | Basement-Unfi | B | 1,692 | 26.01 | 1993 | | 78 | | 0.00 | 30,300 |

| BUILDING SUB-AREA SUMMARY SECTION | | | | | | |
|-----------------------------------|------------------------|-------------|------------|----------|-----------|----------------|
| Code | Description | Living Area | Floor Area | Eff Area | Unit Cost | Undeprec Value |
| BAS | First Floor | 2,140 | 2,140 | 2,140 | 268.19 | 573,929 |
| BMT | Basement Area | 0 | 1,692 | 0 | 0.00 | 0 |
| FPC | Open Porch Conc. Floor | 0 | 24 | 0 | 0.00 | 0 |
| GAR | Attached Garage | 0 | 624 | 0 | 0.00 | 0 |
| UAT | Attic, Unfinished | 0 | 1,864 | 186 | 26.76 | 49,884 |
| WDK | Wood Deck | 0 | 588 | 0 | 0.00 | 0 |
| Ttl Gross Liv / Lease Area | | 2,140 | 6,932 | 2,326 | | 623,813 |

